

REVISIONS					
P	LTR	DESCRIPTION	DATE	OWN	APVD
A1		REVISED PER ECR-17-012945	21SEP2017	JB	SD

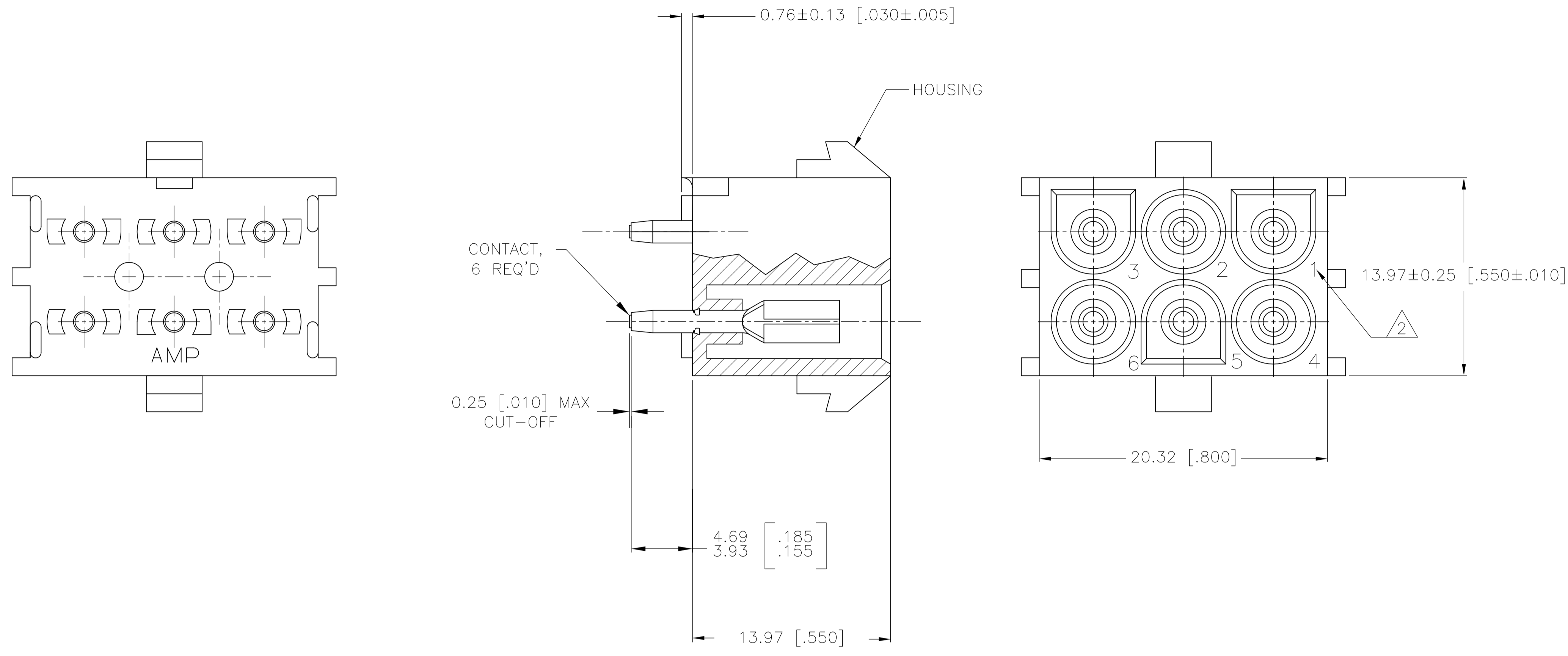

- 1 PARTS MUST COMPLY WITH AMP SOLDERABILITY SPEC 109-11-3.
- 2 CIRCUIT IDENTIFICATION CHARACTERS ARE ADJACENT TO THE INDICATED CAVITIES, BUT LOCATION AND ORIENTATION MAY DIFFER FROM PRINT.
- 3 FLAMMABILITY UL V-0 FOR THICKNESS 0.4, 0.45, 0.8, 1.6, AND 3.0 PER IEC 60695-11-10.
- 4 GLOW WIRE FLAMMABILITY (GWF): 960°C FOR THICKNESS 0.45, 0.8, 1.6, AND 3.0 PER IEC 60695-2-12.
- 5 GLOW WIRE IGNITION (GWIT): 825°C FOR THICKNESS 0.45, 800°C FOR THICKNESS 0.8, 775°C FOR THICKNESS 1.6 AND 3.0 PER IEC 60695-2-13.

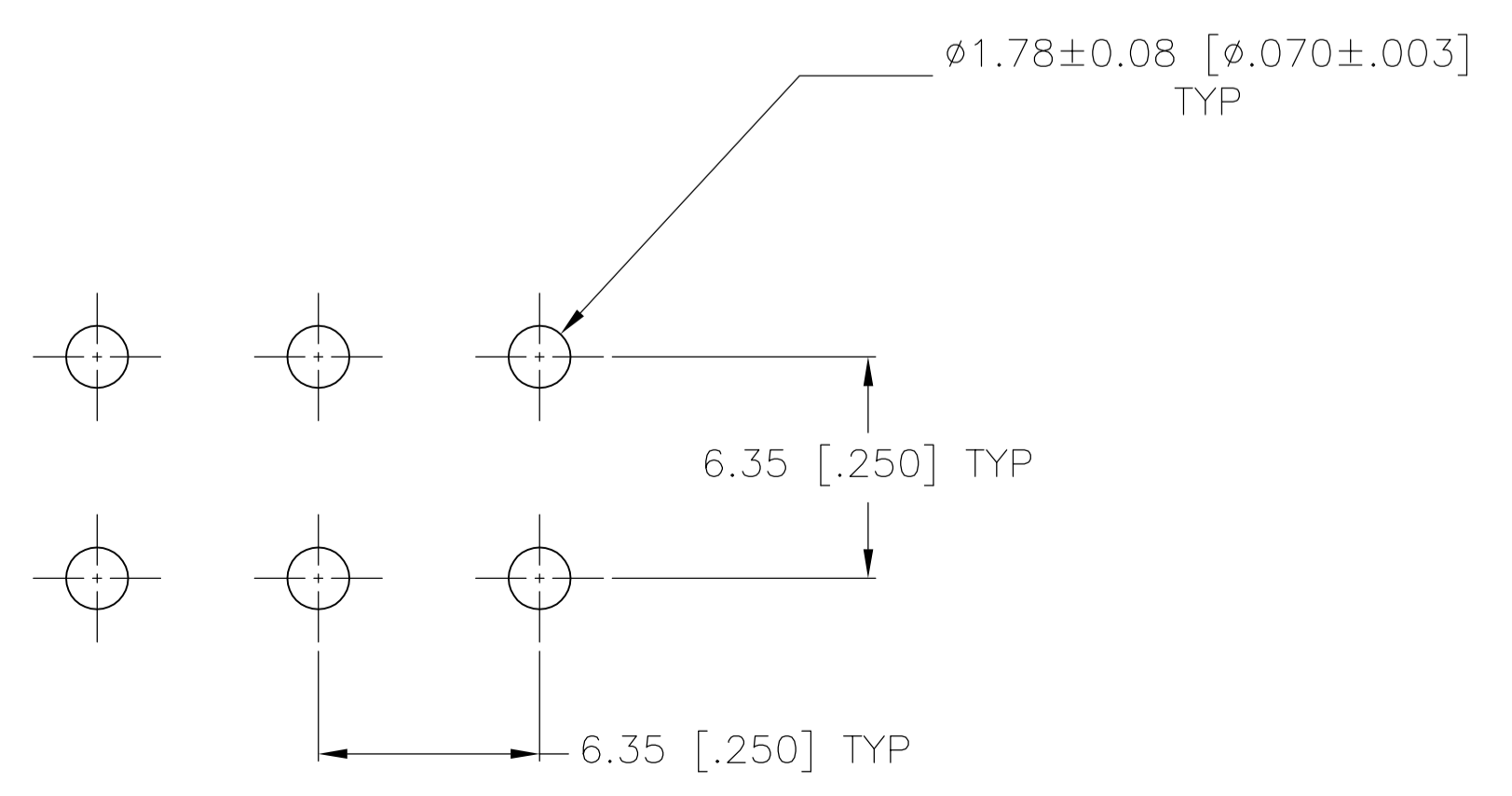

RECOMMENDED LAYOUT FOR 1.58 [.062] THICK PC BOARD

PH BRZ TIN	NYLON, UL V-0 GW, NATURAL	1969811-1
CONTACT	HOUSING	PART NO
THIS DRAWING IS A CONTROLLED DOCUMENT. DWN: BASVESH WARAD 07JAN2016 OR: WICKES EVAN 07JAN2016 APVD: WICKES EVAN 07JAN2016 NAME: WICKES EVAN PRODUCT SPEC: 6 CIRCUIT UNIVERSAL MATE-N-LOK (TM) P.C. BOARD SOCKET HEADER ASSEMBLY APPLICATION SPEC: — WEIGHT: 0.000000 CUSTOMER DRAWING		
DIMENSIONS: mm [INCHES] 0 PLC ± 1 PLC ± 2 PLC ± 3 PLC ± 0.13 [.005] 4 PLC ± ANGLES ±		TOLERANCES UNLESS OTHERWISE SPECIFIED: TYP
MATERIAL: SEE TABLE	FINISH: SEE TABLE	RESTRICTED TO: A1
SCALE: 5:1		SHEET 1 OF 1 REV A1

单击下面可查看定价，库存，交付和生命周期等信息

[>>TE Connectivity\(泰科\)](#)