

THIS DRAWING IS UNPUBLISHED. RELEASED FOR PUBLICATION
 © COPYRIGHT - By - ALL RIGHTS RESERVED.

REVISIONS				
P	LTR	DESCRIPTION	DATE	APVD
	F3	REVISED PER ECO-16-004800	08SEP2016	NK MZ

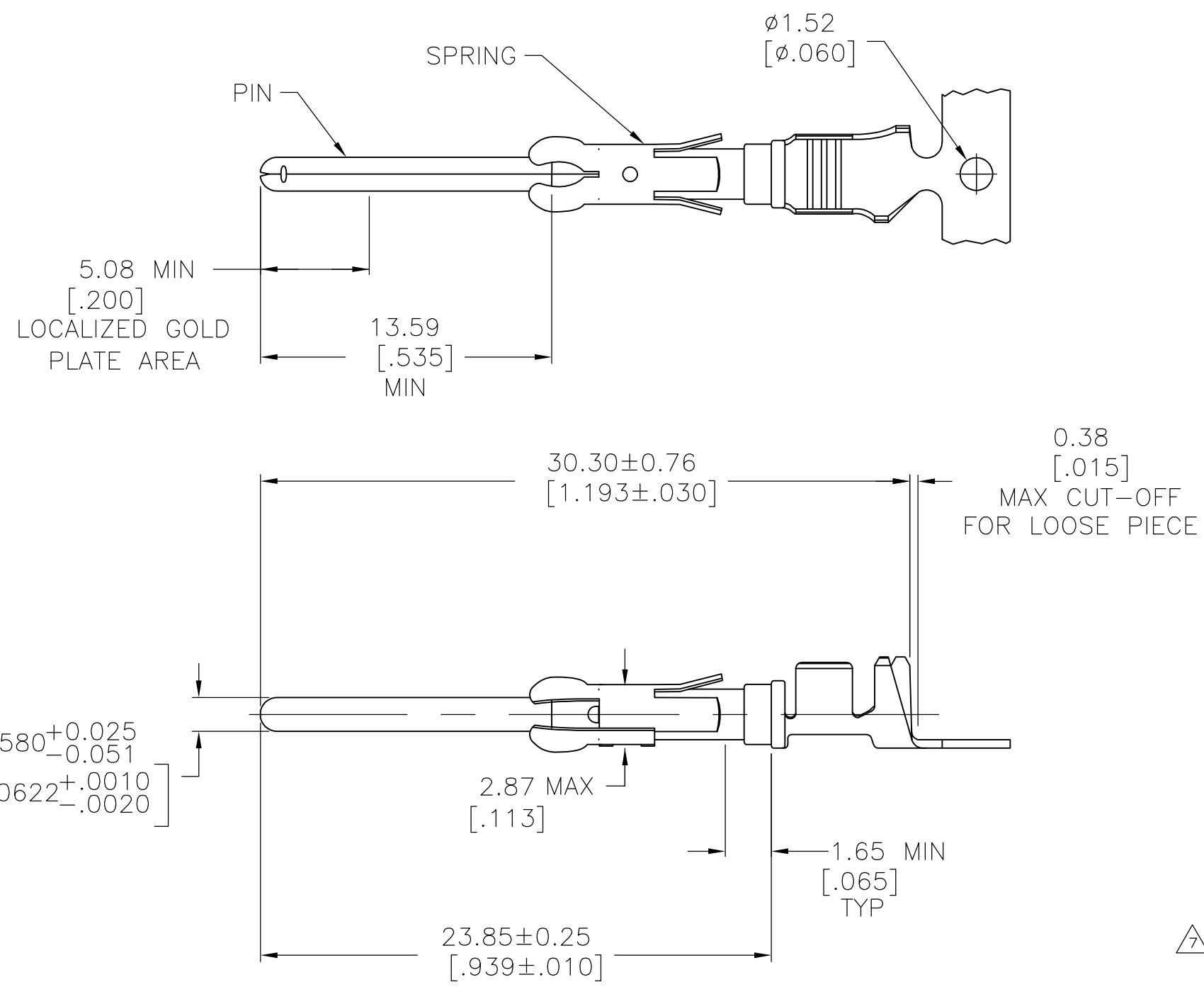

- 1 STAINLESS STEEL.
- 2 BRASS.
- 3 1.27 μ m [0.000050] MIN TIN-LEAD OVER 1.27 μ m [0.000050] MIN NICKEL.
- 4 WIRE RANGE: 14-18 AWG. INSULATION RANGE: 2.79-3.81 [0.110-0.150] DIA.
- 5 0.76 μ m [0.000030] MIN GOLD IN LOCALIZED GOLD PLATE AREA, OVER 1.27 μ m [0.000050] MIN NICKEL.
- 6 1.27 μ m [0.000050] MIN TIN OVER 1.27 μ m [0.000050] MIN NICKEL.
- 7 OBSOLETE PARTS: OBSOLETE CIS STREAMLINING PER D.RENAUD/D.SINISI

	LOOSE PIECE	6	213603-6
	STRIP	6	213603-5
7	OBSOLETE LOOSE PIECE	5	213603-4
	STRIP	5	213603-3
OBSOLETE	LOOSE PIECE	3	213603-2
	STRIP	3	213603-1
	DESCRIPTION	PIN FINISH	PART NO.

THIS DRAWING IS A CONTROLLED DOCUMENT.		DWN L.SIPE 05/07/90	STE TE Connectivity	
DIMENSIONS: mm [INCHES]		CHK R STONE 5-17-90		
TOLERANCES UNLESS OTHERWISE SPECIFIED:		APVD -	NAME	
0 PLC ± -		PRODUCT SPEC -	PIN ASSEMBLY, 5015 SERIES, 14-18 AWG, SPECIAL TYPE III+	
1 PLC ± -		APPLICATION SPEC -	SIZE	CAGE CODE
2 PLC ± 0.13 [0.005]		WEIGHT	A3	00779
3 PLC ± -		CUSTOMER DRAWING	DRAWING NO	C-213603
4 PLC ± -		SCALE	4:1	SHEET 1 OF 1
ANGLES ± -		RESTRICTED TO	-	
FINISH SEE TABLE		REV	F3	
MATERIAL SPRING: 1				
PIN: 2				

单击下面可查看定价，库存，交付和生命周期等信息

[>>TE Connectivity\(泰科\)](#)