

THIS DRAWING IS UNPUBLISHED. RELEASED FOR PUBLICATION  
 © COPYRIGHT - By - ALL RIGHTS RESERVED.

LOC		DIST		REVISIONS			
P	LTR	DESCRIPTION	DATE	DWN	APVD		
	T	REVISED PER ECR-12-013323	09AUG12	KH	TM		
	T1	REVISED PER ECR-14-001607	11FEB14	AV	GK		

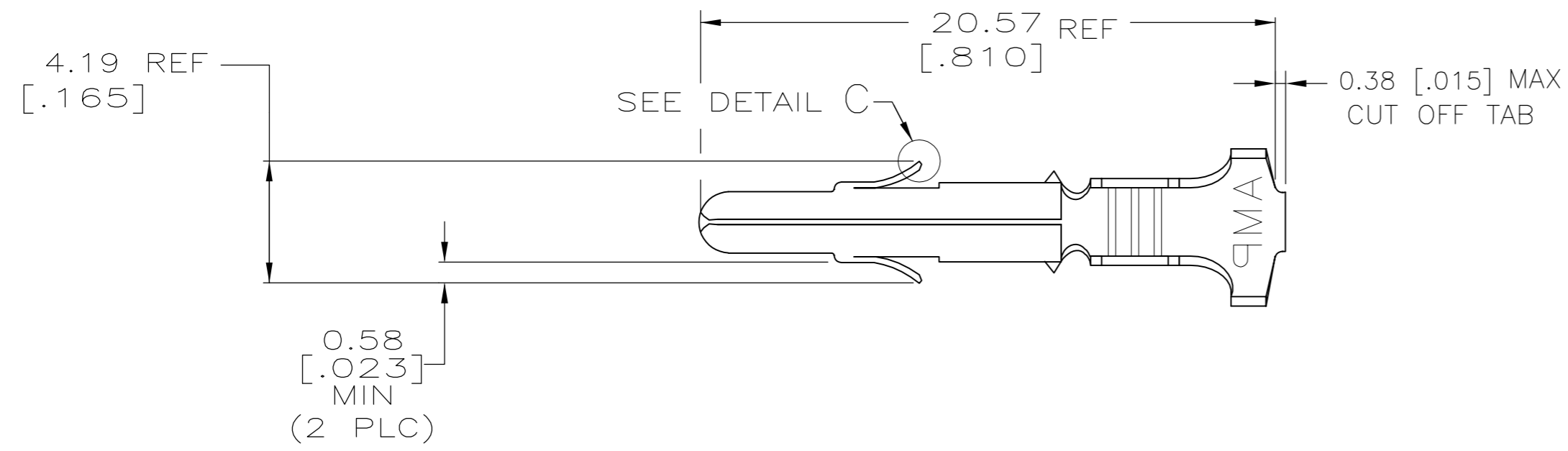

- 1 PLATED WITH 0.00076[.000030] GOLD OVER 0.00127[.000050] MIN THK NICKEL UNDERPLATE.
- 2 GOLD OVER NICKEL ON ENTIRE STAMPING; 0.00076[.000030] GOLD MINIMUM AT OINT OF MEASUREMENT IN CONTACT AREA, GOLD FLASH MINIMUM IN WIRE BARREL.
- 3 DIMENSIONS IN BRACKETS ARE IN INCHES.
- 4 WIRE RANGE: 20-14 AWG  
INSULATION RANGE : 3.30-5.08 [.130-.200] DIA.

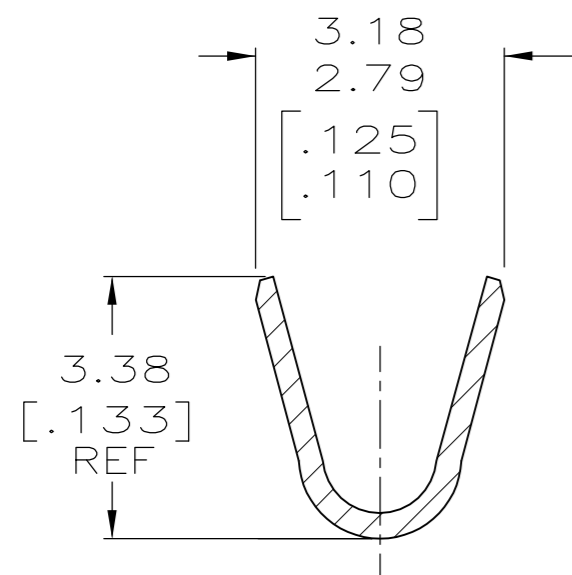
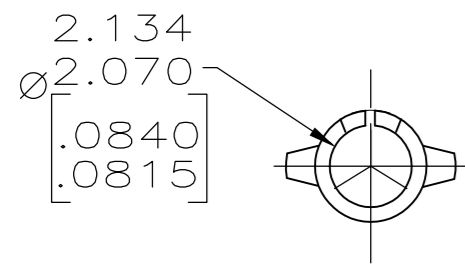
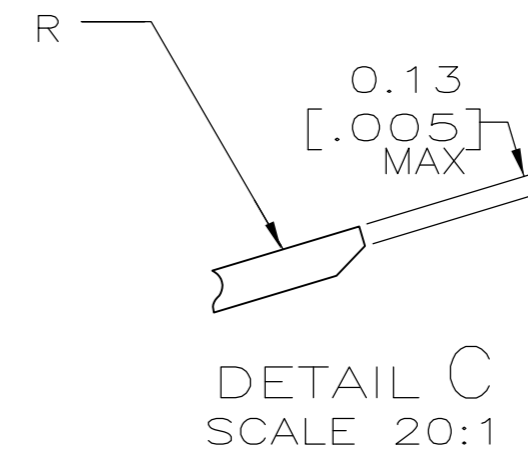
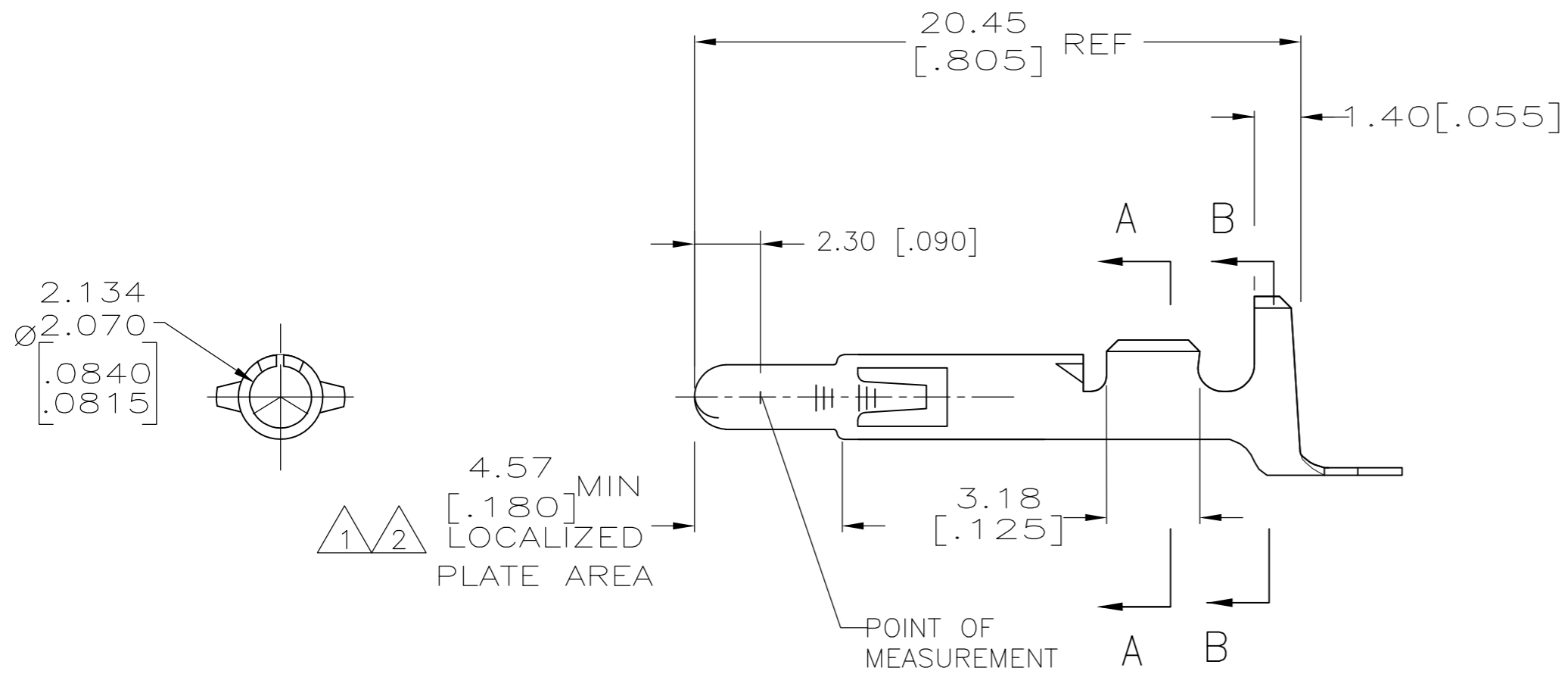

SECTION A-A  
SCALE 10:1

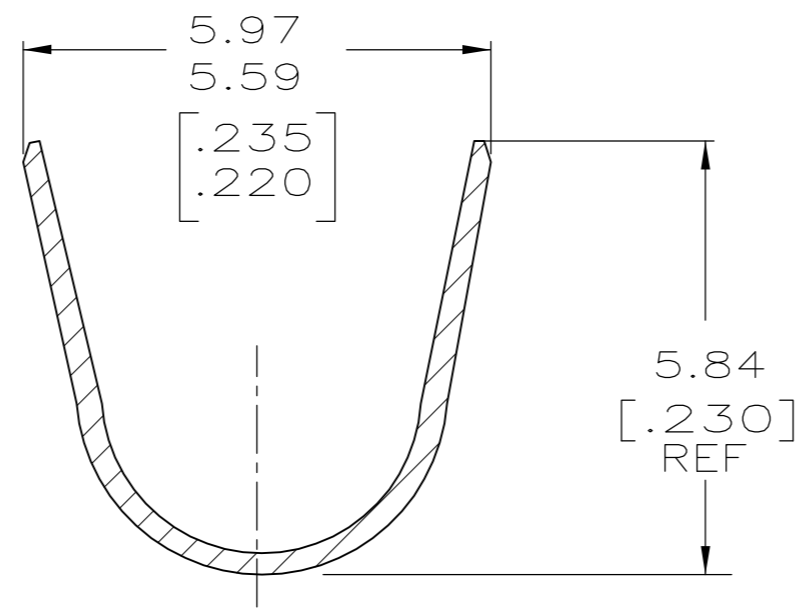

SECTION B-B  
SCALE 10:1

FINISH	MATERIAL	PART NO
GOLD 2	0.30 [.012] BRASS	350552-7
GOLD 2	0.30 [.012] PH BZ	350552-6
TIN	0.30 [.012] PH BZ	350552-3
GOLD 1	0.30 [.012] BRASS	350552-2
TIN	0.30 [.012] BRASS	350552-1

THIS DRAWING IS A CONTROLLED DOCUMENT.		DWN K. WHITAKER 12NOV2004			
DIMENSIONS: mm [INCHES]		CHK S. RIDGILL 12NOV2004			
TOLERANCES UNLESS OTHERWISE SPECIFIED:		APVD S. RIDGILL 12NOV2004	NAME PIN, (LOOSE PIECE), UNIVERSAL MATE-N-LOK™		
0 PLC ± - 1 PLC ± - 2 PLC ± 0.13 [.005] 3 PLC ± - 4 PLC ± - ANGLES ± 0°30'		PRODUCT SPEC APPLICATION SPEC	SIZE A2	CAGE CODE 00779	DRAWING NO C=350552
MATERIAL -		FINISH -	WEIGHT -	RESTRICTED TO -	SCALE 5:1
CUSTOMER DRAWING			SHEET 1 OF 1	REV T1	

单击下面可查看定价，库存，交付和生命周期等信息

[>>TE Connectivity\(泰科\)](#)