

LOC		DIST		REVISIONS			
P	LTR	DESCRIPTION	DATE	DWN	APVD		
P2		REVISED PER ECR-12-011660	25JAN13	KH	TM		

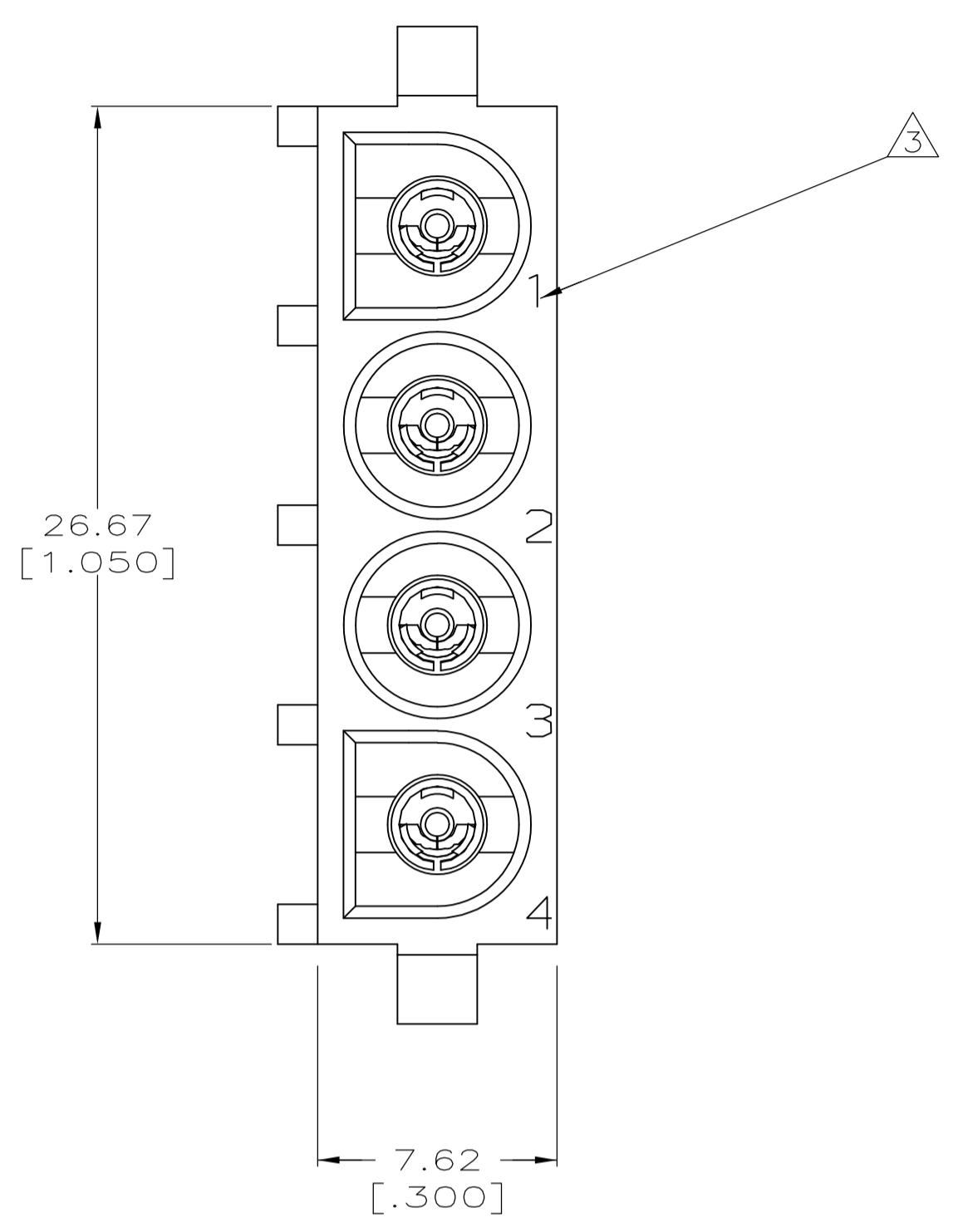

- 1 PARTS COMPLY TO AMP SOLDERABILITY SPECIFICATION 109-11-3.
- 2 CONTACT IS PLATED OVERALL WITH 0.00127 [.000050] NICKEL, THEN 0.00076 [.000030] GOLD OVER CONTACT LENGTH INDICATED AND MATTE TIN LEAD ON SOLDER TAIL END.
- 3 CIRCUIT IDENTIFICATION CHARACTERS ARE ADJACENT TO THE INDICATED CAVITIES, BUT LOCATION AND ORIENTATION MAY DIFFER FROM PRINT.
- 4 DIMENSIONS IN BRACKETS ARE IN INCHES.
- 5 DRAIN HOLES LOCATED AS SHOWN. OPTIONAL CONSTRUCTION - ALL DRAIN HOLES LOCATED 90° AS SHOWN IN DETAIL A.
- 6 CONTACT IS PLATED OVERALL WITH 0.00127 [.000050] NICKEL, THEN 0.00076 [.000030] GOLD OVER CONTACT LENGTH INDICATED AND MATTE TIN ON SOLDER TAIL END.
- 7 SUPERSEDED BY 350826-4

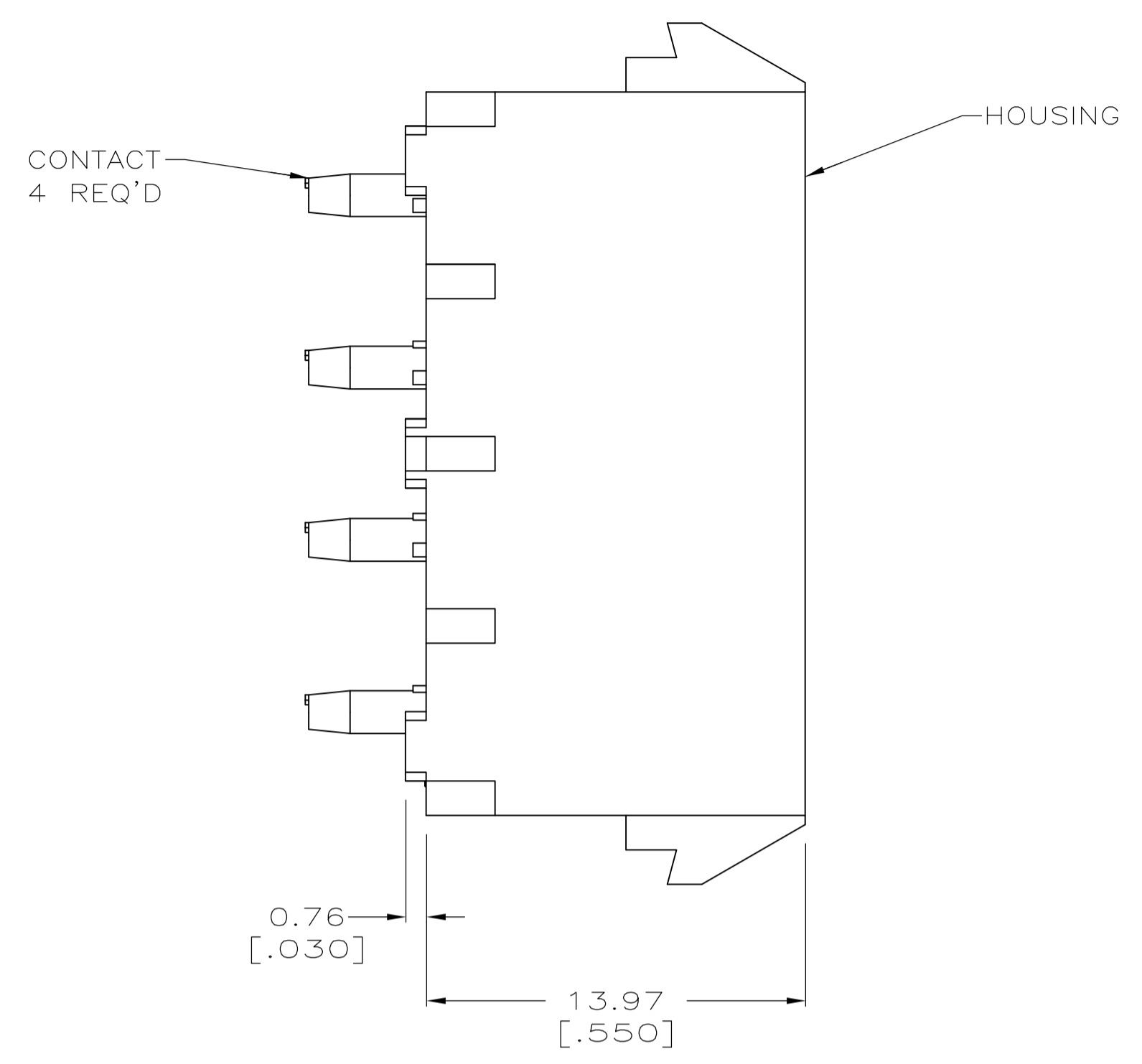
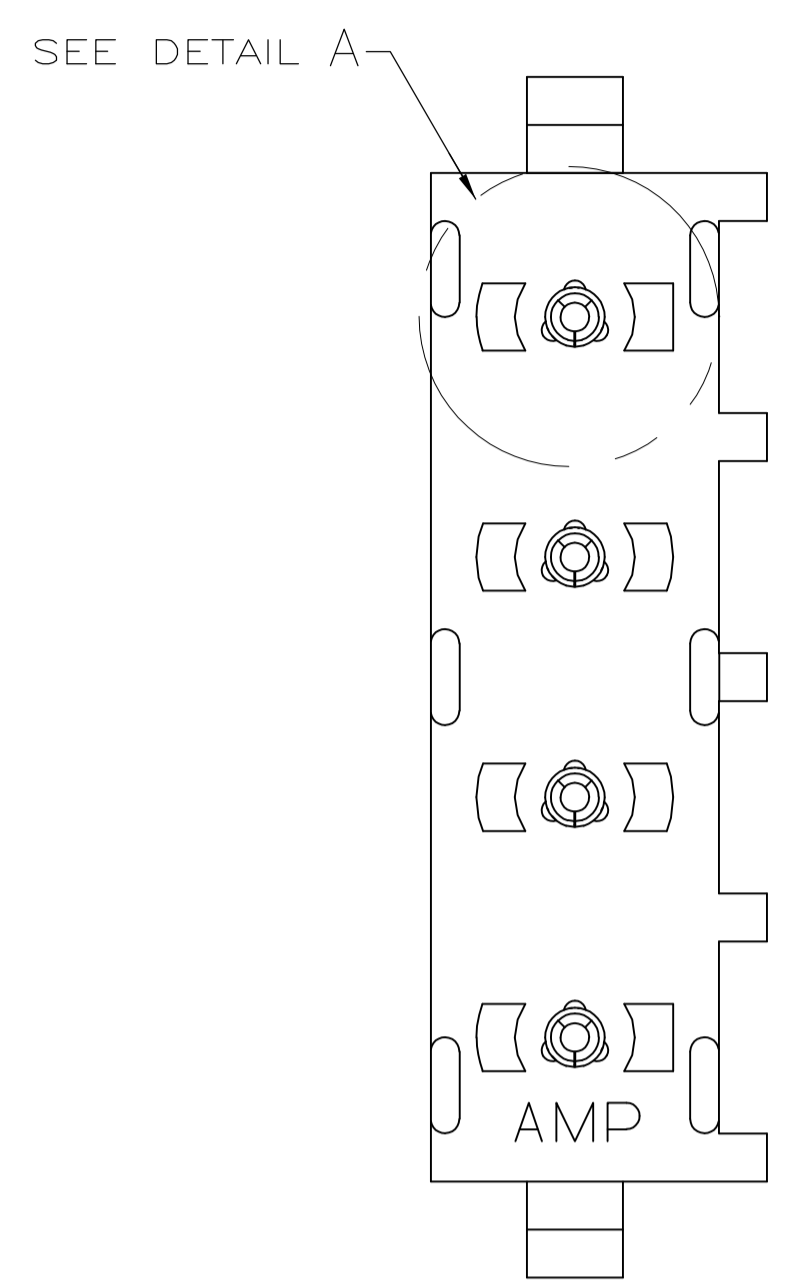
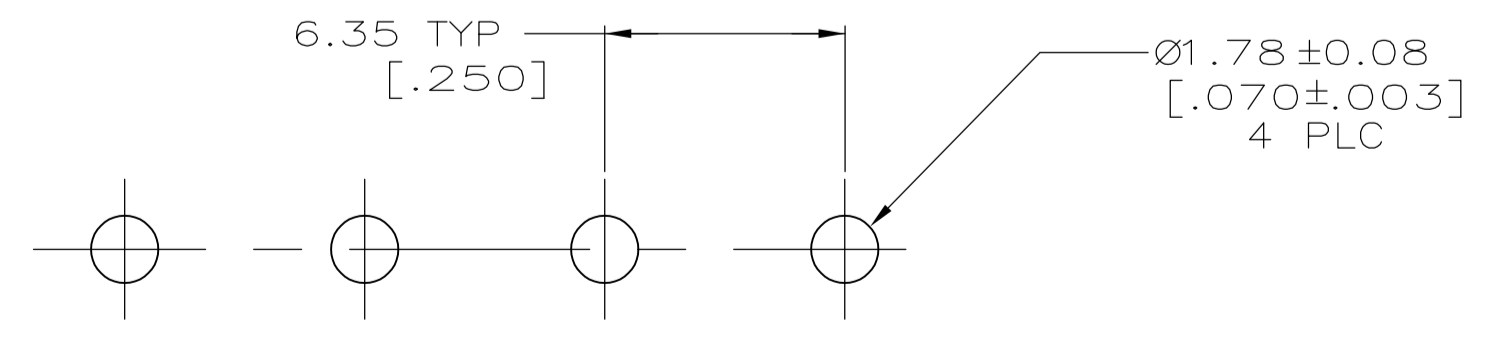
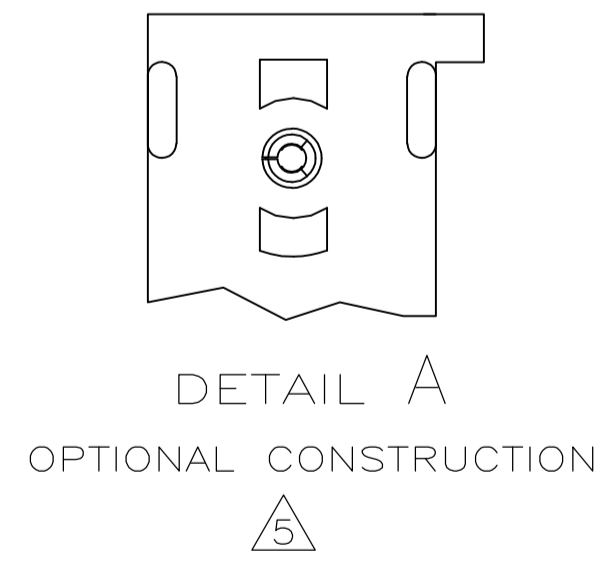
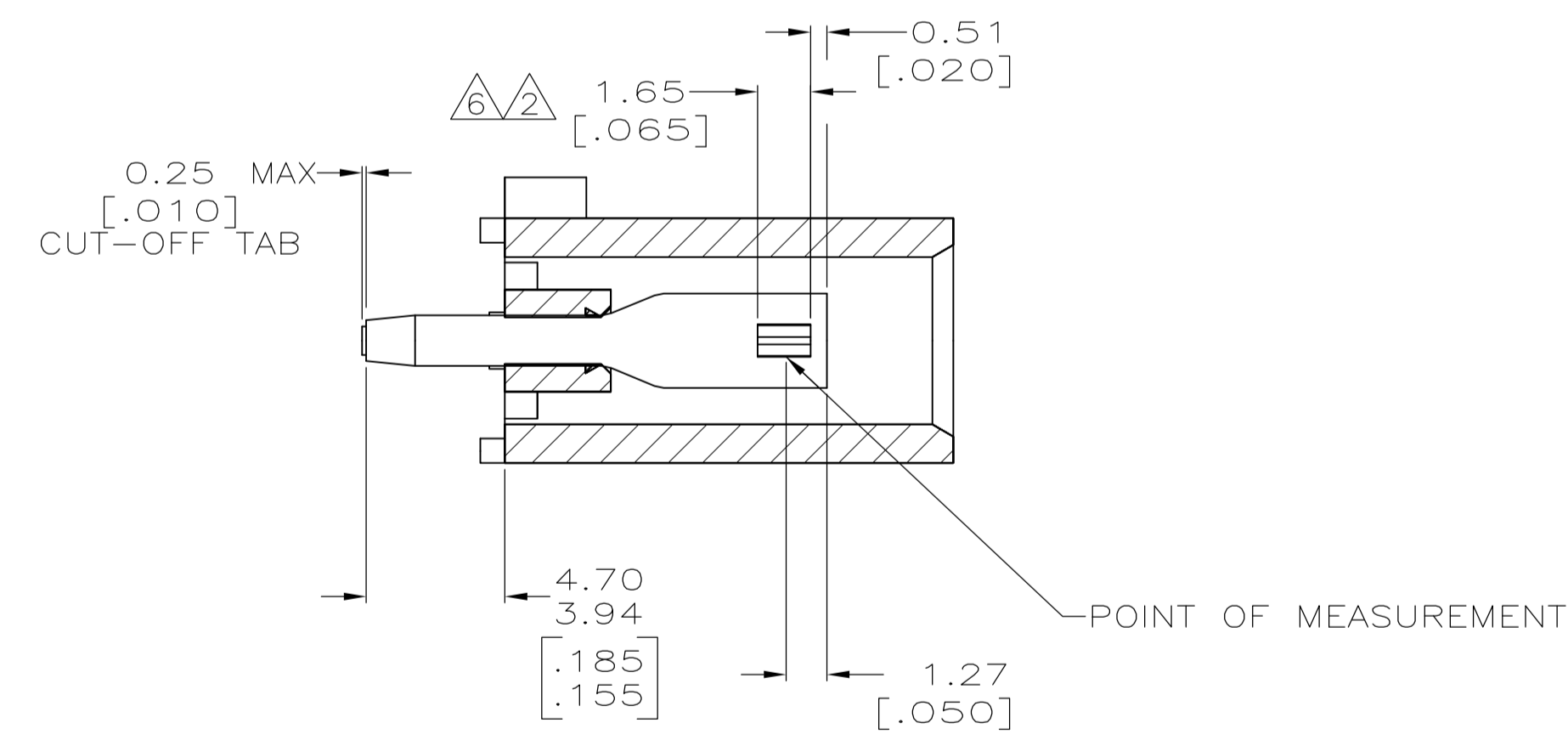
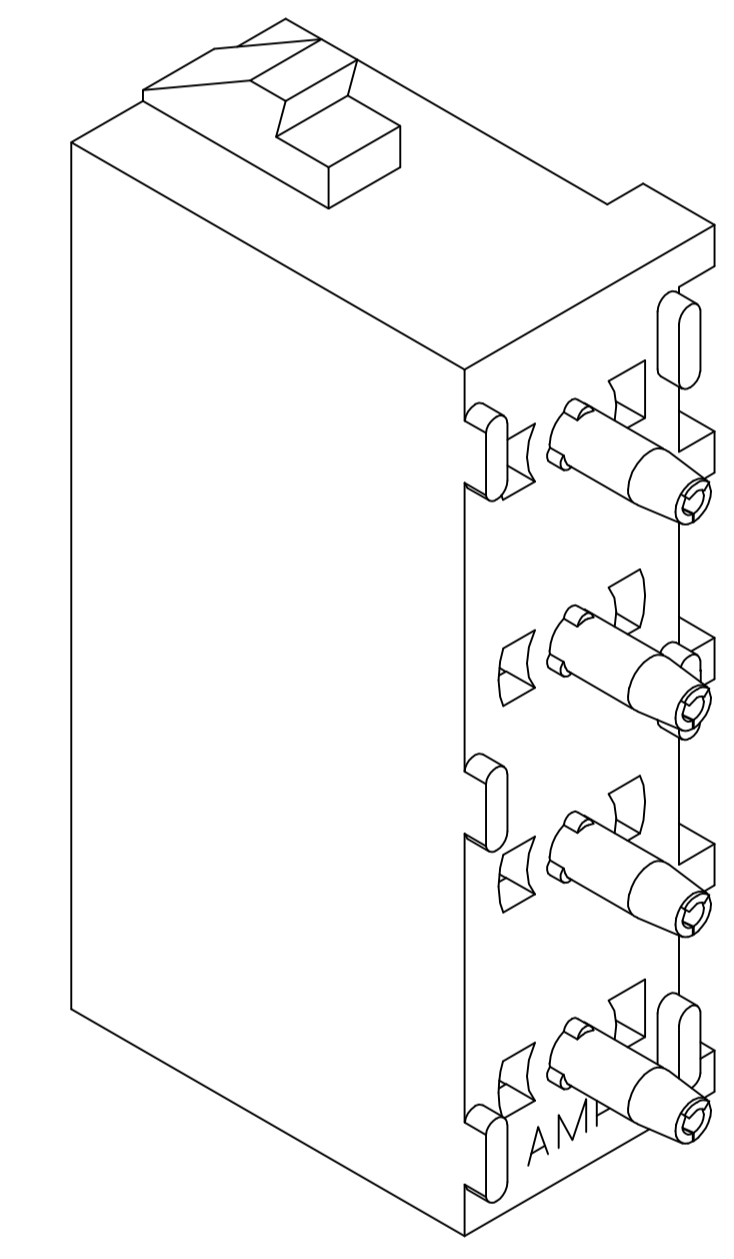

RECOMMENDED MOUNTING HOLE PATTERN FOR 1.57 [.062] THICK P.C. BOARD

PHOSPHOR BRONZE, GOLD	NYLON, UL94V-0, WHITE	350826-4
PHOSPHOR BRONZE, GOLD	NYLON, UL94V-0, WHITE	350826-2
PHOSPHOR BRONZE, PRE-TIN	NYLON, UL94V-0, WHITE	350826-1
CONTACT MATERIAL AND FINISH	HOUSING MATERIAL	PART NUMBER

THIS DRAWING IS A CONTROLLED DOCUMENT.		DIN R LEWIS 10-02-98	STE TE Connectivity	
DIMENSIONS: mm [INCHES]		CHK R SWING 10-02-98	NAME	
TOLERANCES UNLESS OTHERWISE SPECIFIED:		APVD M TRULL 10-02-98	PRODUCT SPEC	
0 PLC ± -	1 PLC ± -	APPLICATION SPEC		
2 PLC ± 0.13 [.005]	3 PLC ± -	SIZE CASE CODE DRAWING NO		
4 PLC ± -	ANGLES ± 0°30'	RESTRICTED TO		
MATERIAL SEE TABLE	FINISH SEE TABLE	WEIGHT	A1 00779 C=350826	SCALE 5:1 SHEET 1 OF 1 REV P2
CUSTOMER DRAWING				

单击下面可查看定价，库存，交付和生命周期等信息

[>>TE Connectivity\(泰科\)](#)