

SUGGESTED GAGE FOR "G" DIM. INSULATION CRIMP

SUPERSEDED BY INSTRUCTION SHEET 1535
DATE *10-21-70* **ECN.**

GAGE DIMENSIONS APPLY WHEN TOOL IS BOTTOMED BUT NOT UNDER PRESSURE.

FOR REPLACEMENT OF PARTS OTHER THAN LISTED, TOOL SHOULD BE RETURNED TO OUR FACTORY TO INSURE PROPER CERTI-CRIMP ADJUSTMENT.

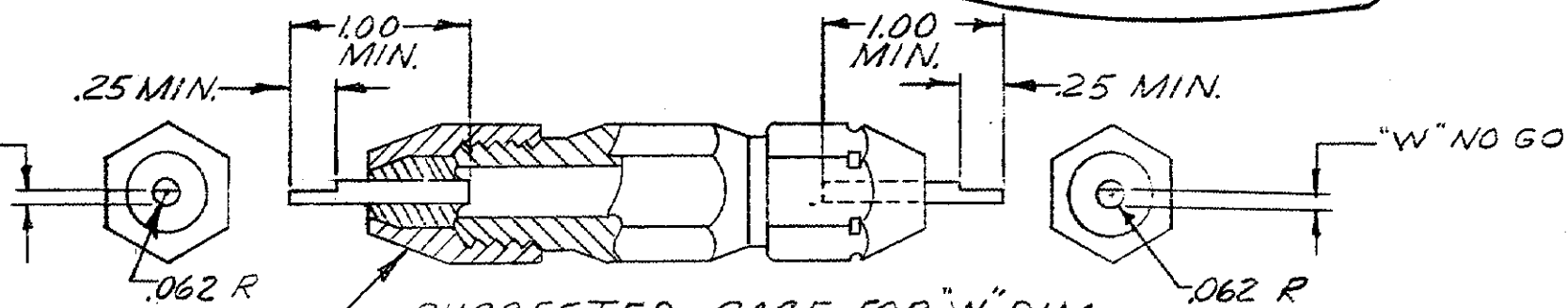

SUGGESTED GAGE FOR "W" DIM. BARREL CRIMP

DOUBLE END HANDLE A.G.D. STANDARD

2	A	39207	PIN-ADJUSTMENT	7
2	A	21045-6	RING-RETAINING	6
1	A	300449	PIN-RETAINING	5
1	A	39364	SPRING	4
1	A	39366	COLLAR	3
2	A	300432	PIN-RETAINING	2
4	A	21045-3	RING-RETAINING	1

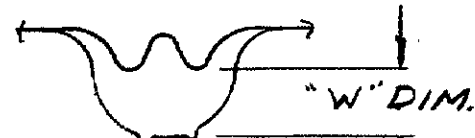
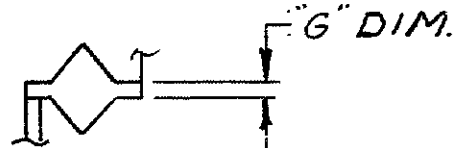

INSULATION CRIMP

BARREL CRIMP

GAGE DIM.			
"G" AT POS. #1		"W" DIM.	
GO	NOGO	GO	NOGO
.045	.065	.067	.073

REV	DESCRIPTION	BY	CHK	DATE
G	SUPERSEDED BY I.S. 1535	EJF	10-21-70	
F	REVISED	B.S. DJF	4-29-67	
E	REVISED	B.S. DJF	4-29-67	
D	REVISED	C.M. C.M.	12-22-63	
C	REVISED	C.M. C.M.	1-3-63	
B	REVISED	R.Y. DJF	6-14-62	
LTR	REVISION RECORD	DR	CHK	DATE

QTY	DESCRIPTION	REQUIRED PER ASSEMBLY
46988	HAND TOOL ASSEMBLY	1

DWG NO.	46988	DATE	4-24-62
BY	R. J. Hughes	CHK	E. J. Frank
DE		APP	E. J. Frank
NAME	HAND TOOL ASSEMBLY		
MATERIAL AND FINISH	CLASS HIGH TEMPERATURE & HEAT RESISTANT TYPE "W" DIAMOND GRIP STRATOTHERM		
WIRE RANGE	16-14	SCALE	1/2" = 1"
TOLERANCE EXCEPT AS NOTED	± .015	LOC	M
NO	B	REV	G
ITEM NO.	46988		

CUSTOMER COPY REFERENCE ONLY



PRINTED IN U.S.A. DIMENSIONS IN INCHES (10 NOT SCALE PRINT)

单击下面可查看定价，库存，交付和生命周期等信息

[>>TE Connectivity\(泰科\)](#)