

THIS DRAWING IS UNPUBLISHED. RELEASED FOR PUBLICATION  
 © COPYRIGHT 19 BY AMP INCORPORATED. ALL INTERNATIONAL RIGHTS RESERVED.

LOC	DIST	P	F	REVISIONS				
AF	50			ZONE	LTR	DESCRIPTION	DATE	APPD
					P	REVISE PER ECR-13-013738	2/15/14	GRZ/JL

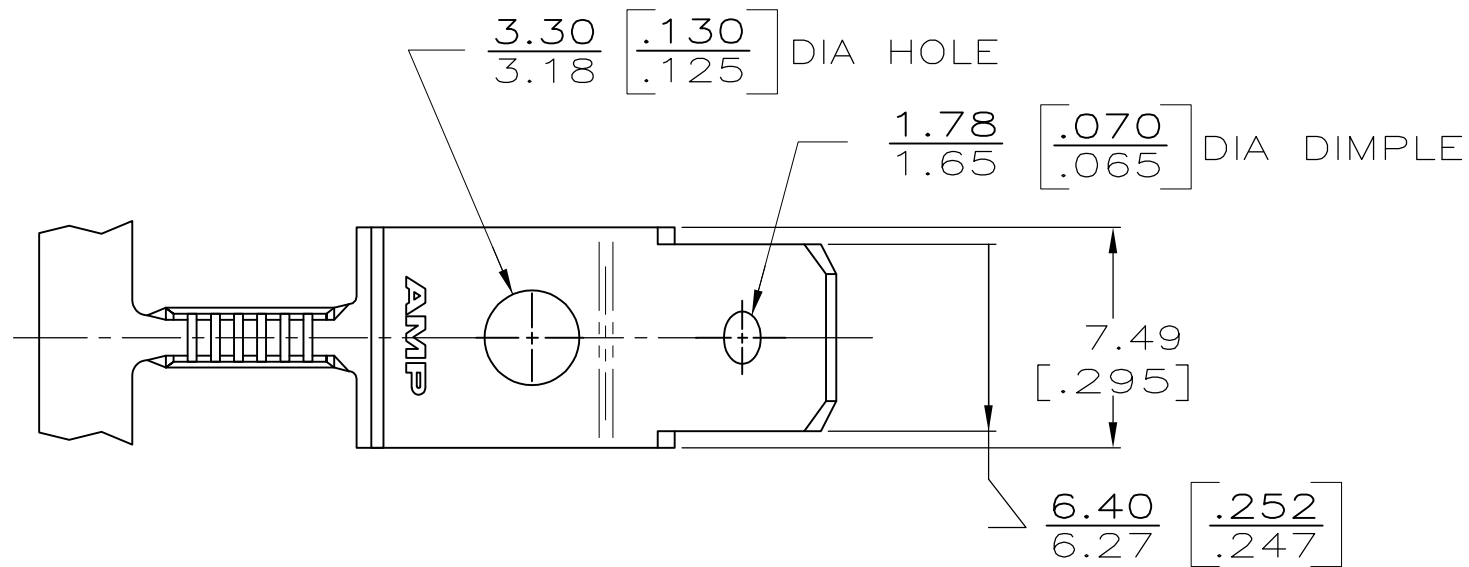

- CONTINUOUS STRIP ON REELS.
- TAB DIMENSIONS ARE IN ACCORDANCE WITH NEMA DC-2 STD.

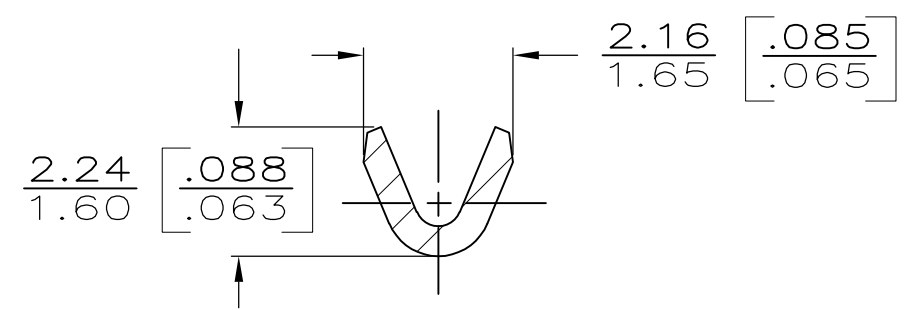
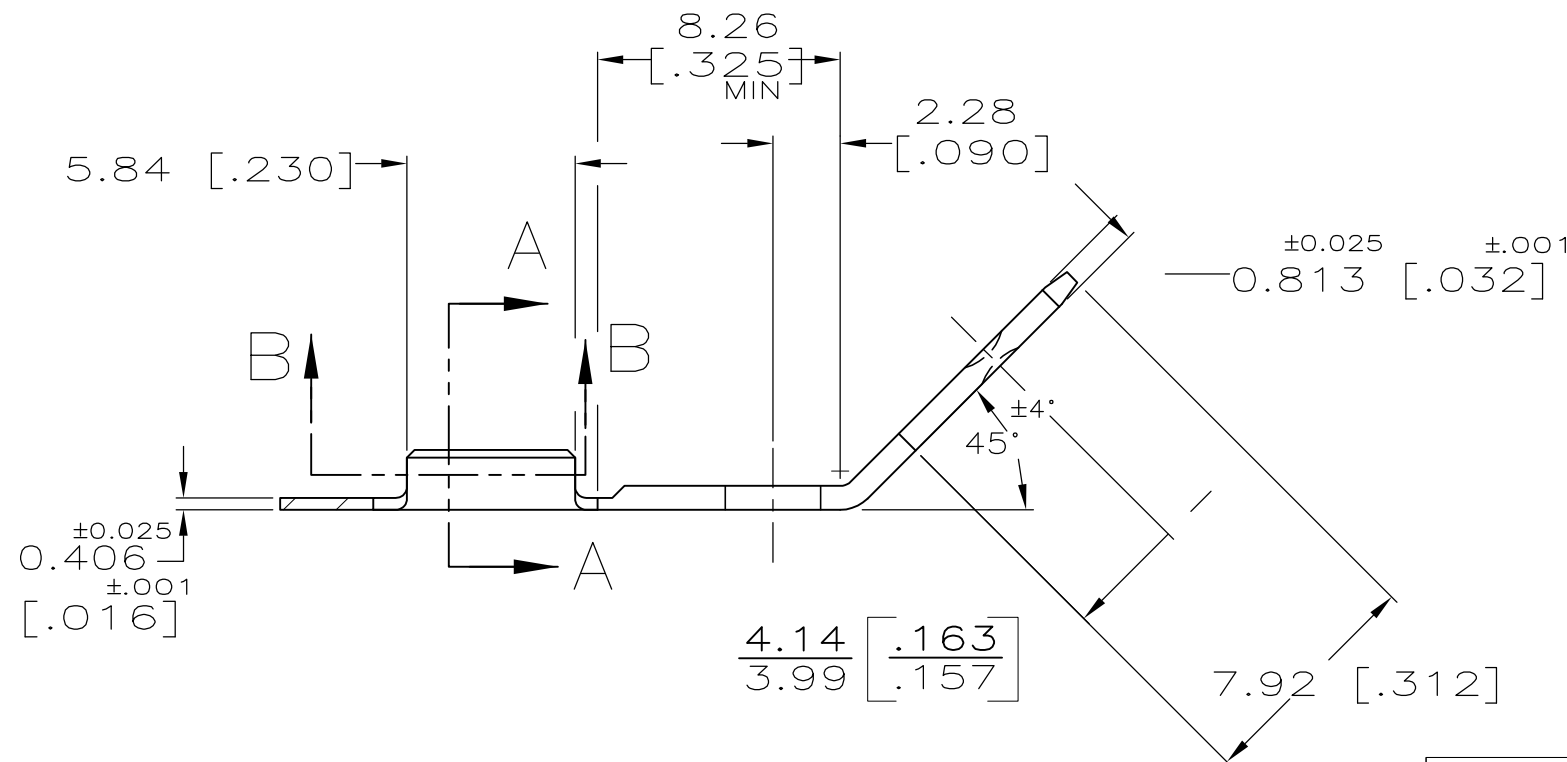

SECTION A-A  
 SCALE 10:1

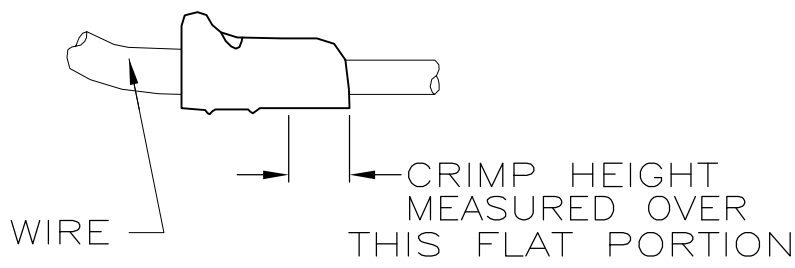

DO NOT SCALE PRINT. UNLESS SPECIFIED DIMENSIONS IN mm [INCHES] TOLERANCES ON: 2 PLC DEC ± 0.25 [.010] 3 PLC DEC ± - ANGLES ± -	DR 2/7/91 JR RUTH CHK 2/7/91 P FORTNEY APPD 2/7/91 R BEAVER APPD 2/7/91 D REINER
MATERIAL  BRASS	PRODUCT SPEC -
FINISH TIN 0.002032 [.000080] MIN WITH VARNISH RESIST	APPLICATION SPEC - WEIGHT -

200-566 CMA	63136-1
WIRE RANGE	PART NO
<b>AMP</b> AMP Incorporated Harrisburg, PA 17105-3608	
NAME TAB, FASTON™ AMPLIVAR, 6.35 [.250] SERIES	
SIZE B	CAGE CODE 00779
SCALE 4:1	DRAWING NO 63136
	SHEET 1 OF 1

单击下面可查看定价，库存，交付和生命周期等信息

[>>TE Connectivity\(泰科\)](#)