

REVISIONS				
P.	LTN	DESCRIPTION	DATE	APVD
A15		REVISED PER ECO-20-004256	25MAR2020	JM DS
-	-	-	-	-
-	-	-	-	-

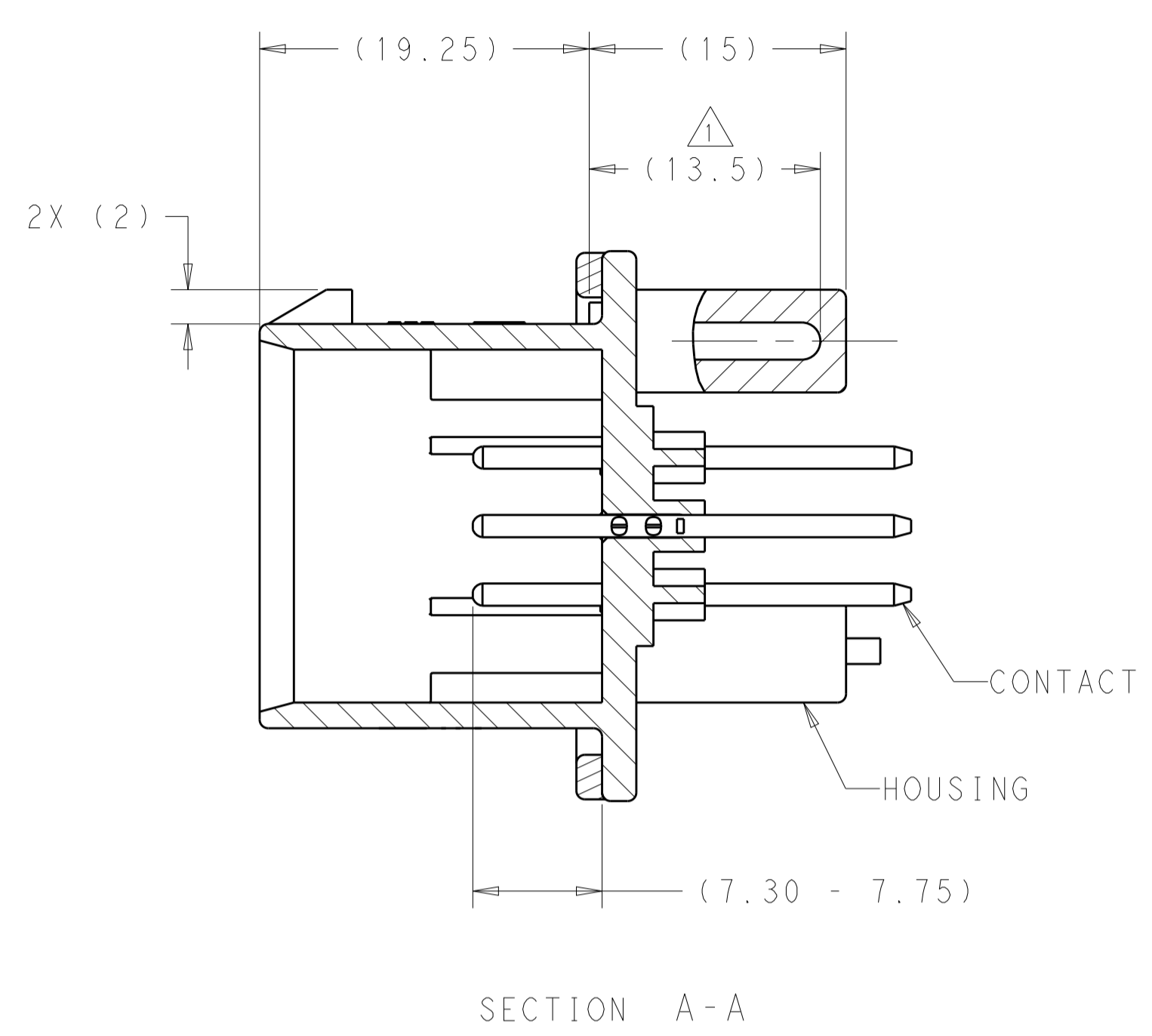

- 1 SUGGESTED MOUNTING SCREW SIZE IS Ø 2.50-3.00mm [Ø 0.099 - 0.118 INCH] SELF TAPPING THREAD FORMING SCREW, SUCH AS DELTA PT, TO BE DRIVEN AT 0.6-0.8 N-m THE CUSTOMER SHOULD TEST THE SCREW SIZE AND TYPE IN ORDER TO VERIFY THEIR SELECTION FOR THEIR APPLICATION
- 2 DATE CODE IN THIS LOCATION USING 5 DIGIT CODE FIRST 2 DIGITS = YEAR, SECOND 2 DIGITS = WEEK LAST DIGIT = DAY.
- 3 MATERIALS: HEADER HOUSING - GLASS FILLED PBT
PINS - TIN OR GOLD PLATED BRASS
GASKET - SILICONE
- 4 HOUSING COLORS ARE MECHANICALLY KEYS TO MATE ONLY WITH IDENTICALLY COLORED PLUG ASSEMBLIES.
- 5. HEADER MATES TO PLUG ASSEMBLY 776164 WHICH USES REELED TERMINAL 770520 OR LOOSE PIECE TERMINAL 770854

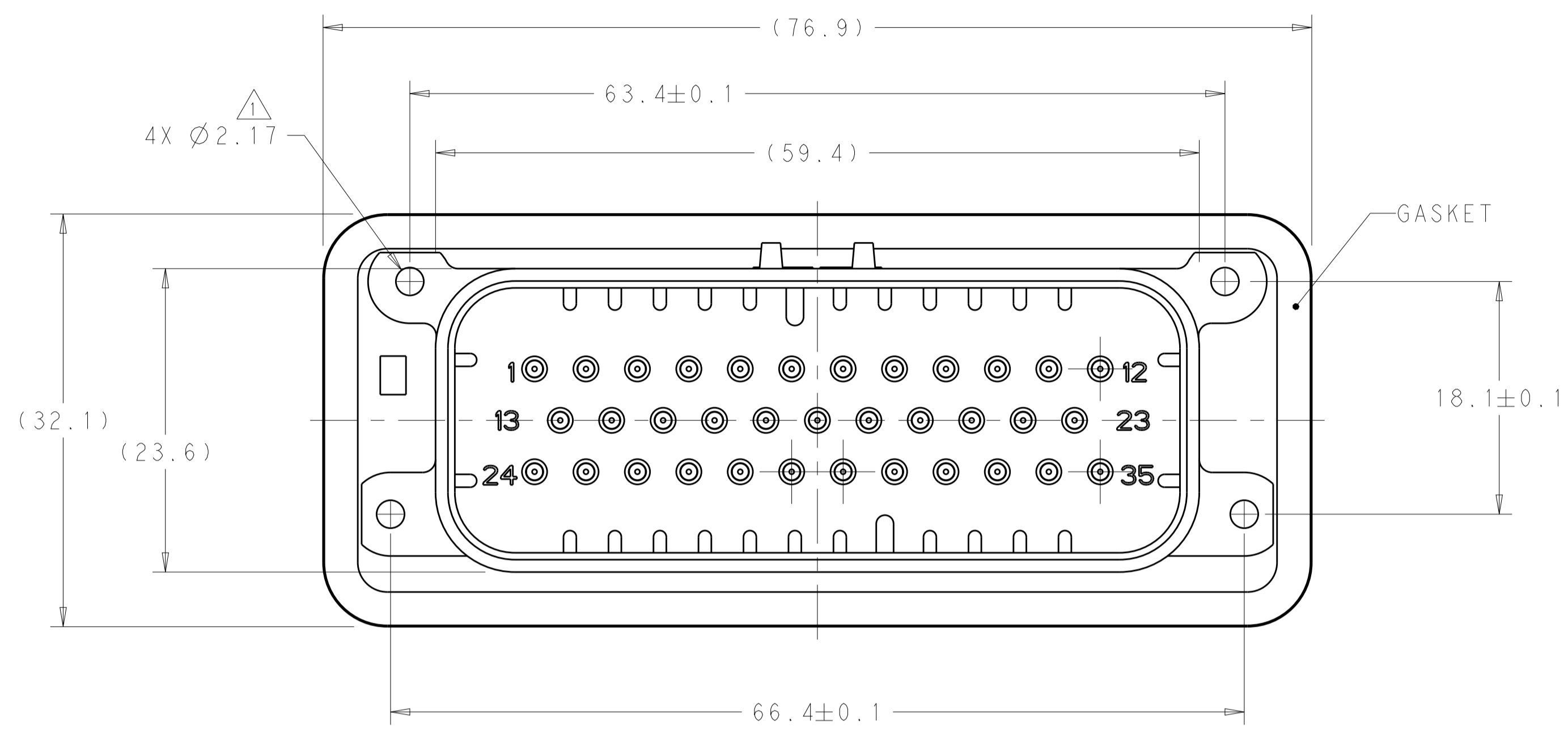
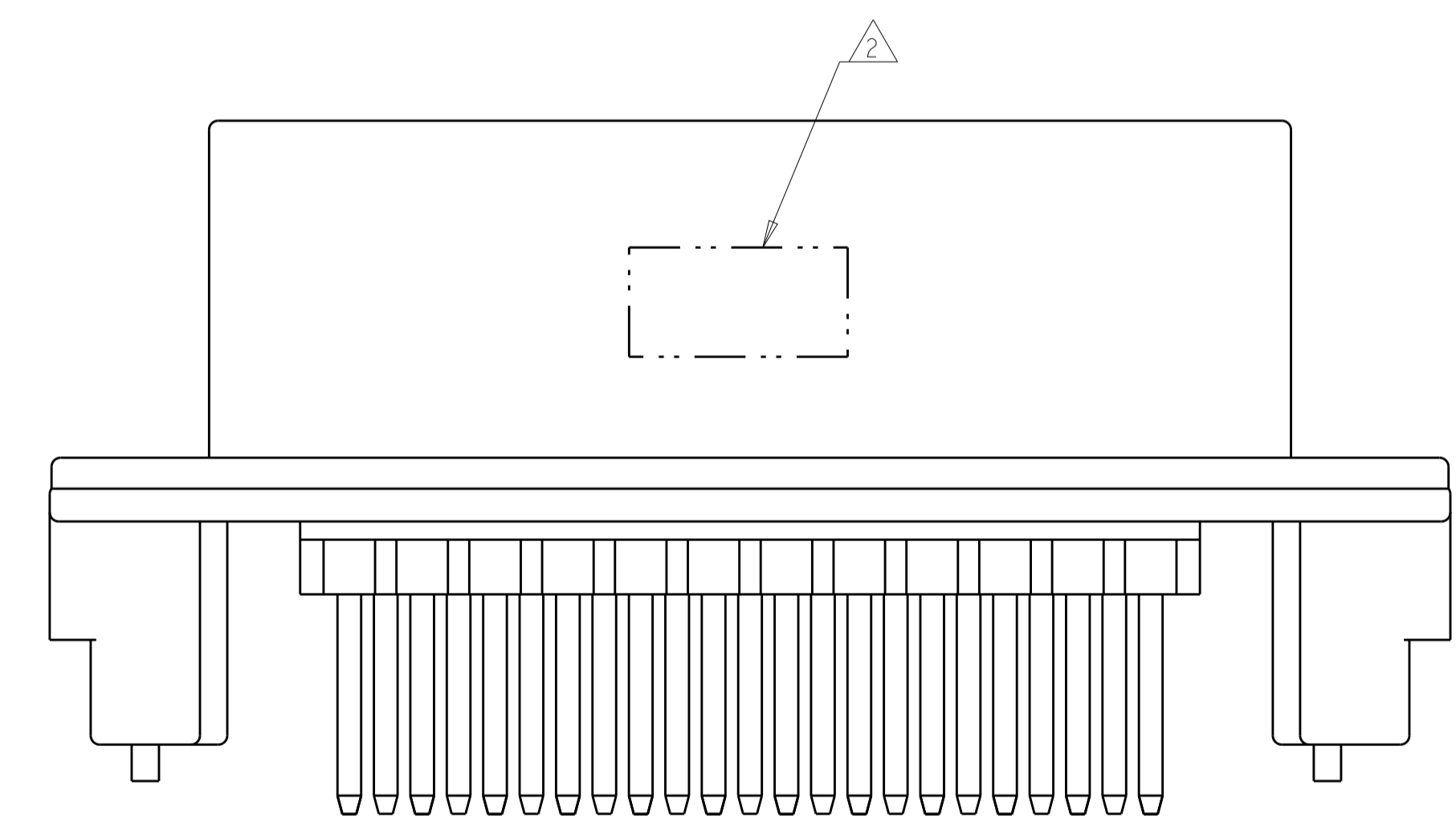

776231-1 & 1-776231-1 SHOWN

HEADER COLOR	PLATING	PART NUMBER
ORANGE	GOLD	1-776231-6
BLUE	GOLD	1-776231-5
GRAY	GOLD	1-776231-4
NATURAL	GOLD	1-776231-2
BLACK	GOLD	1-776231-1
BLUE	TIN	776231-5
GRAY	TIN	776231-4
NATURAL	TIN	776231-2
BLACK	TIN	776231-1

THIS DRAWING IS A CONTROLLED DOCUMENT.		OWN: D. STRAUSSER 05MAR2020	TE Connectivity ASSEMBLY, HEADER, 35 POSITION, VERTICAL, AMPSEAL WITH FLANGE SEAL	
DIMENSIONS: mm		CHK: D. STRAUSSER 22MAR2020		
TOLERANCES UNLESS OTHERWISE SPECIFIED:		APVD: D. STRAUSSER 27APR2020	NAME: ASSEMBLY, HEADER, 35 POSITION, VERTICAL, AMPSEAL WITH FLANGE SEAL	
0 PLC ±		PRODUCT SPEC: 108-1329	SIZE: CAGE CODE DRAWING NO: A100779C=776231	
1 PLC ±0.2		APPLICATION SPEC: 114-16016	RESTRICTED TO: -	
2 PLC ±		WEIGHT: 40.29g	SCALE: 3:1 SHEET 1 OF 2 REV: A15	
3 PLC ±		CUSTOMER DRAWING		
ANGLES ±				
FINISH				

REVISIONS				
P.	LTH	DESCRIPTION	DATE	APVD
-	-	SEE SHEET 1	-	-

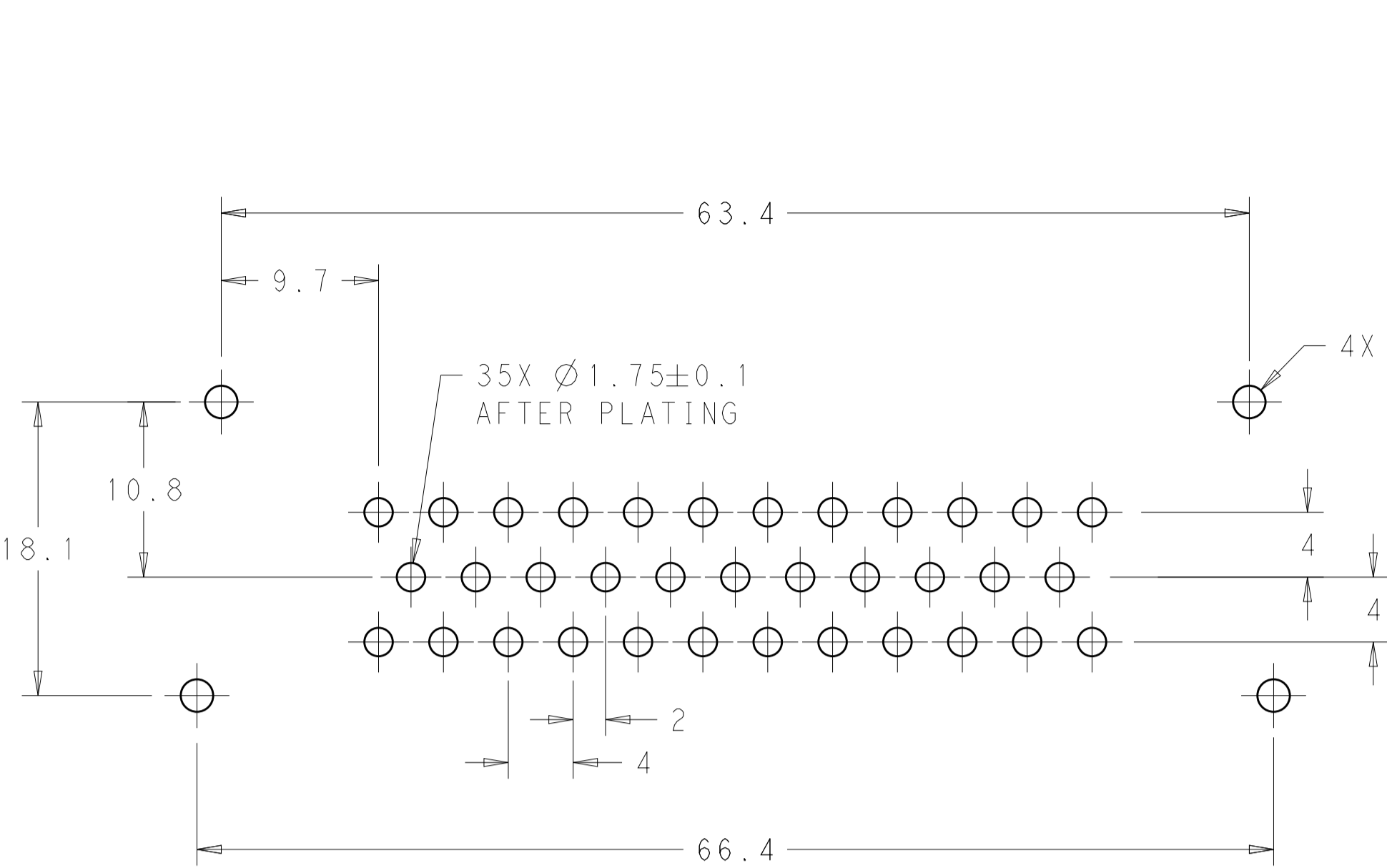

RECOMMENDED P.C. BOARD LAYOUT FOR 1.57 THICK P.C. BOARD

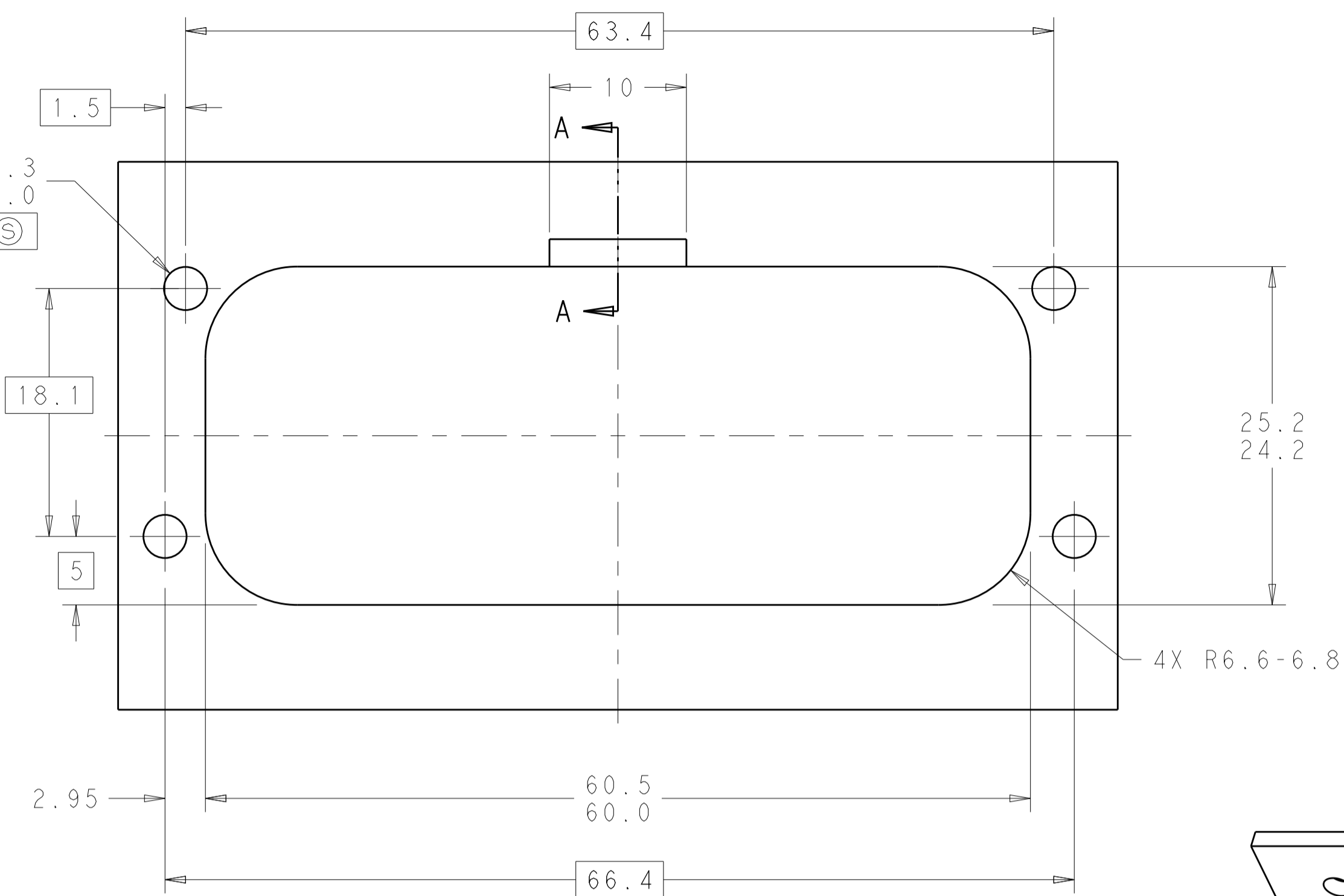

RECOMMENDED MOUNTING HOLE LAYOUT FOR 5.0 MAX THICK PANEL

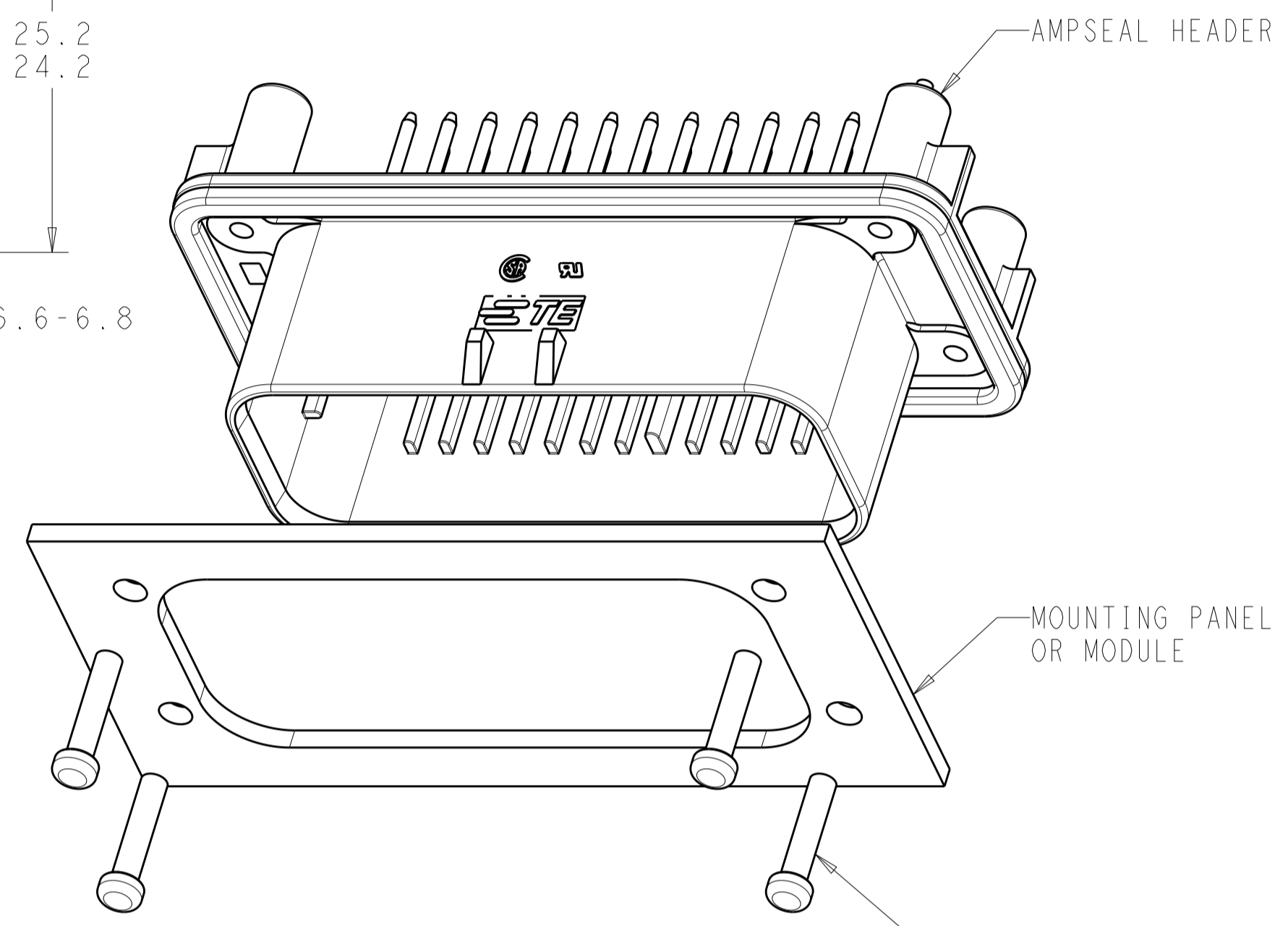

SCALE 2:1

MOUNTING SCREW (4)
TORQUE TO 0.6N-m TO 0.8N-m

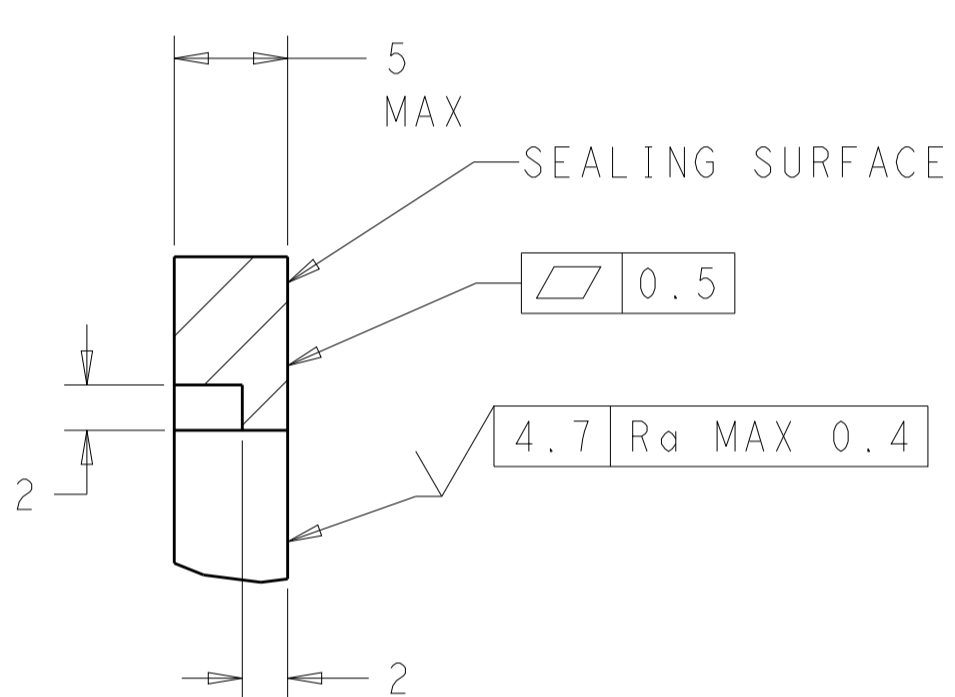

SECTION A-A
OPTIONAL CONSTRUCTION IF PANEL THICKNESS IS GREATER THAN 2.0

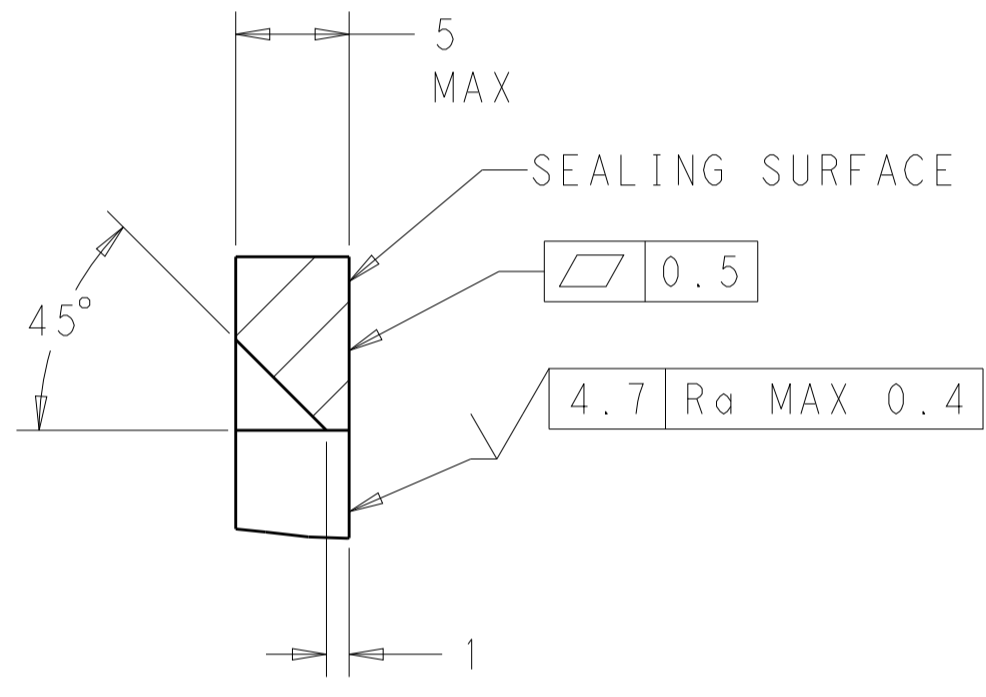

SECTION A-A
OPTIONAL CONSTRUCTION IF PANEL THICKNESS IS GREATER THAN 2.0

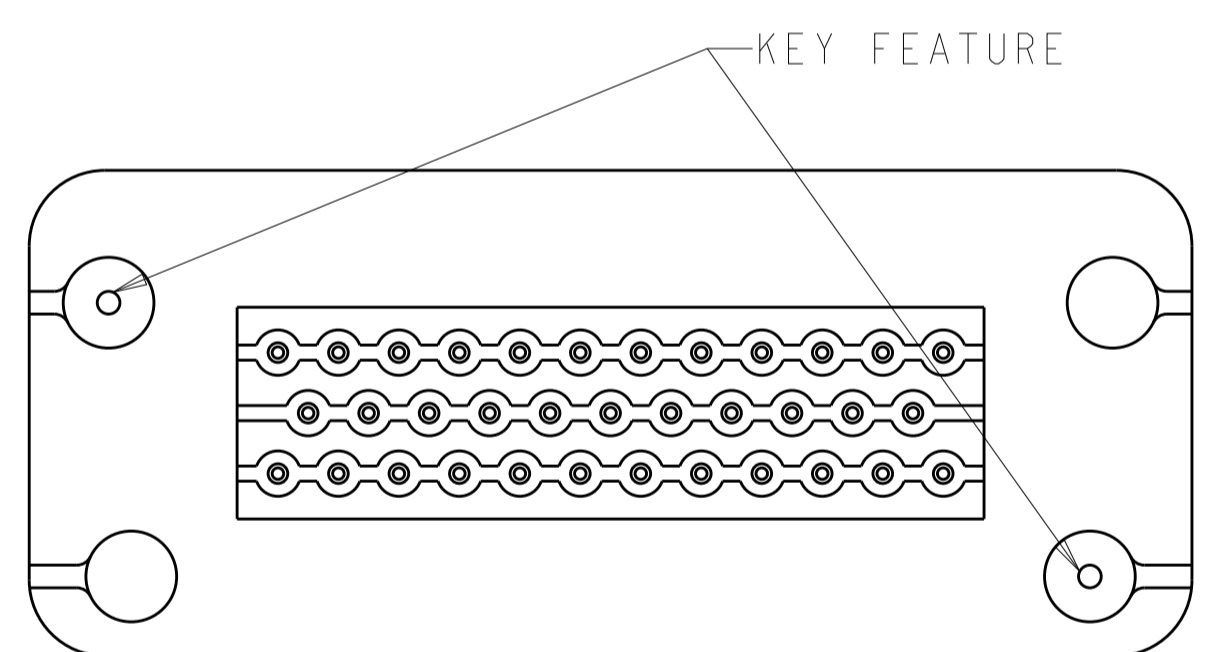

KEYING FOR 776231-1, 1-776231-1, 776231-4, 1-776231-4 AND 1-776231-6
SCALE 2:1

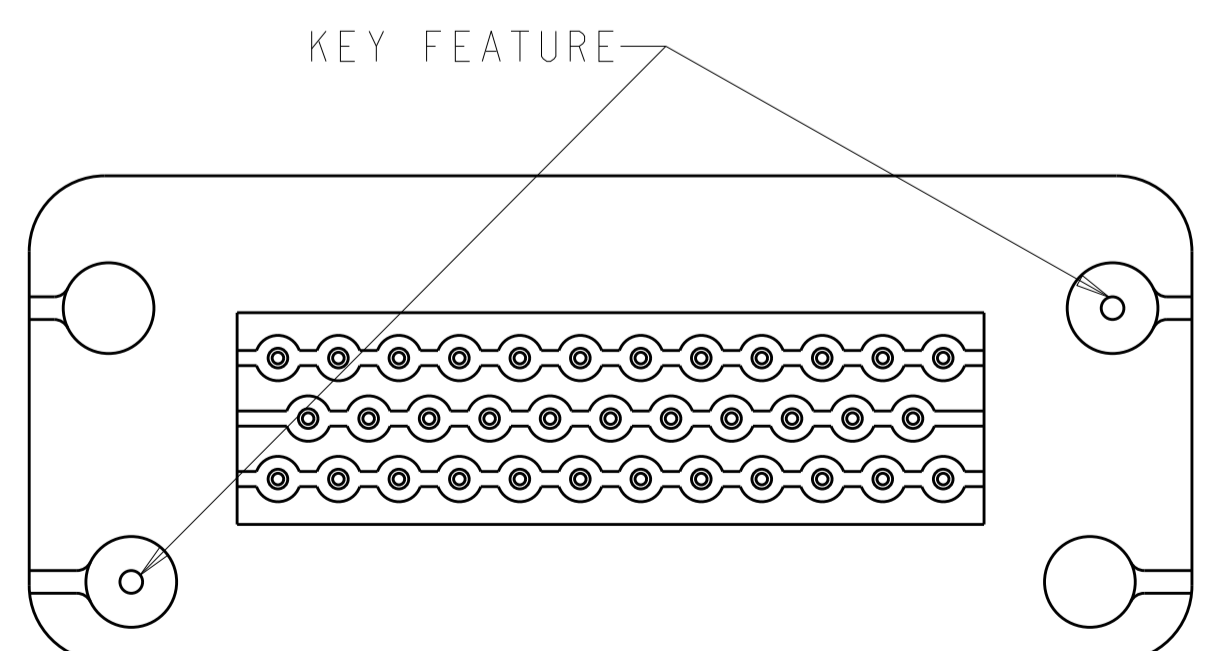

KEYING FOR 776231-2, 1-776231-2, 776231-5 AND 1-776231-5
SCALE 2:1

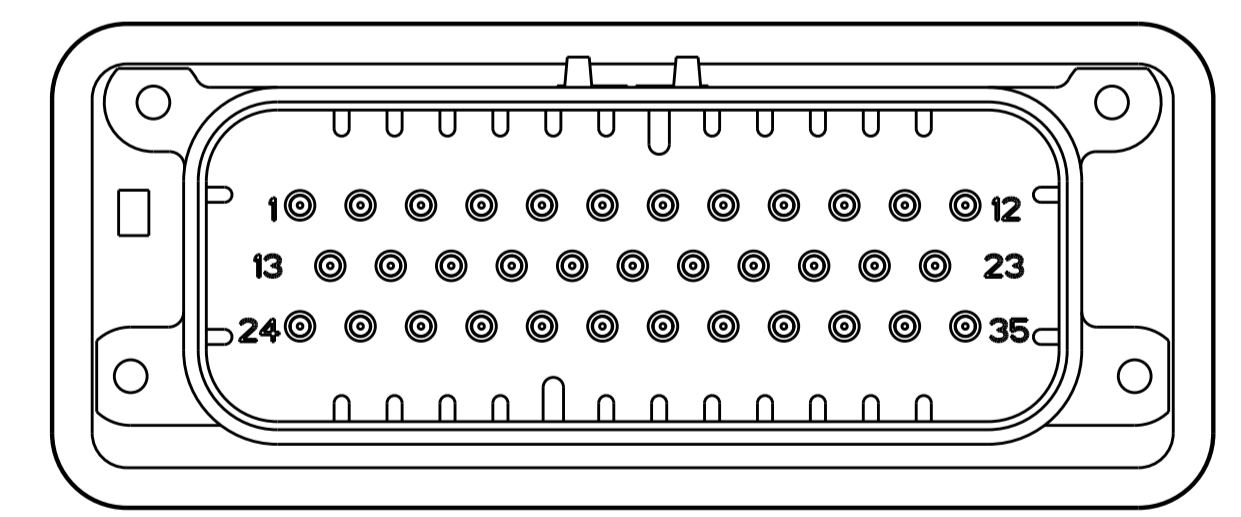
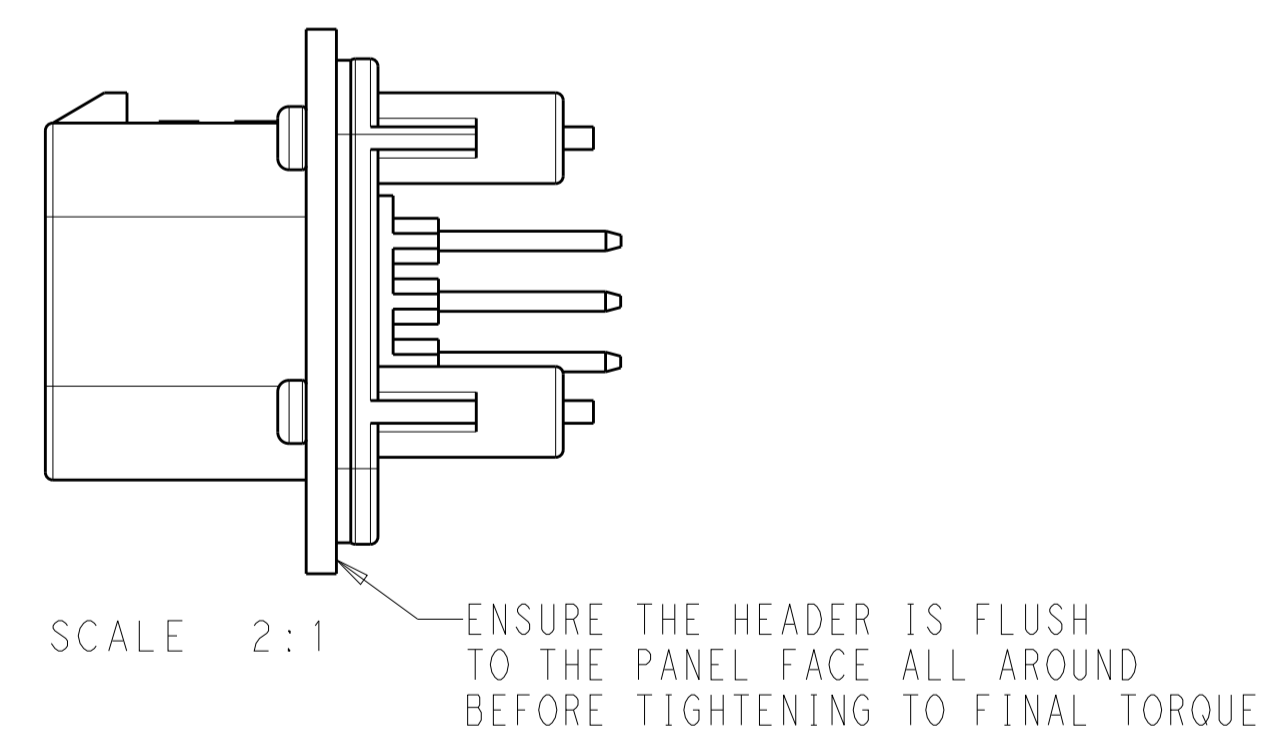

776231-2 & 1-776231-2
KEY LOCATION
SCALE 2:1

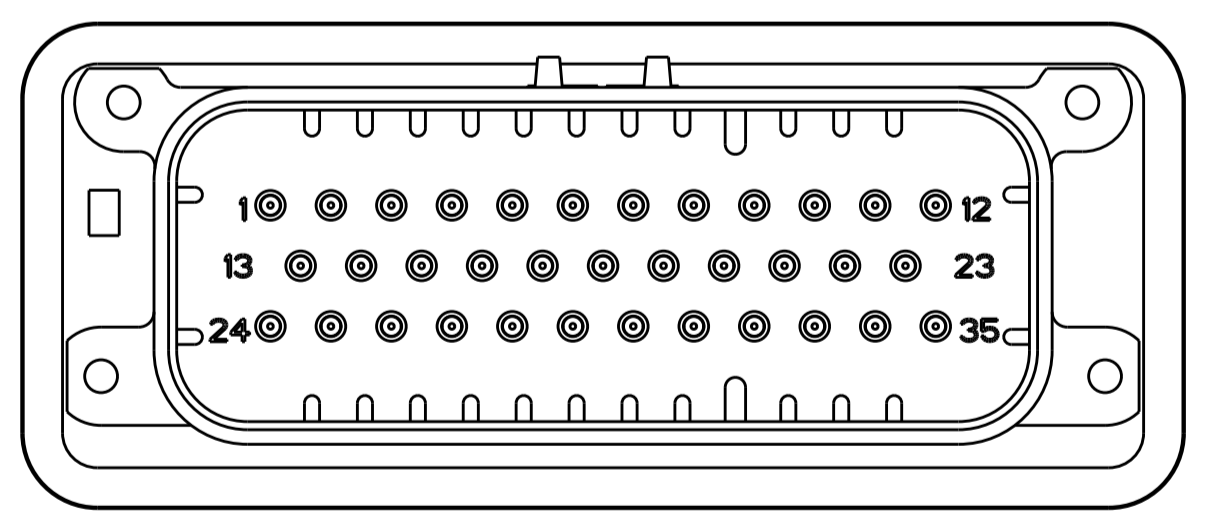

776231-4 & 1-776231-4
KEY LOCATION
SCALE 2:1

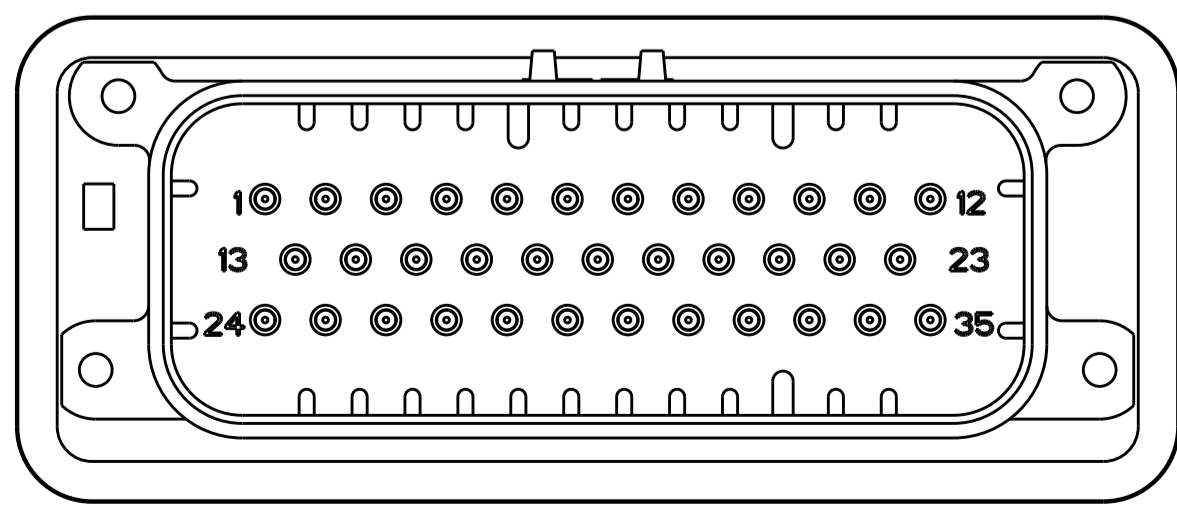

776231-5 & 1-776231-5
KEY LOCATION
SCALE 2:1

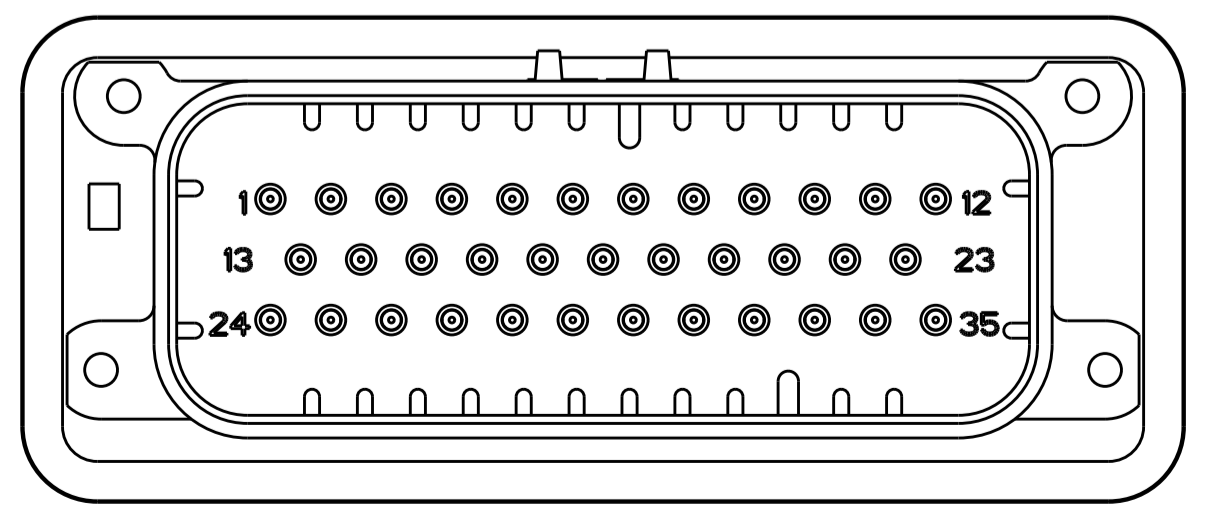

1-776231-6
KEY LOCATION
SCALE 2:1

THIS DRAWING IS A CONTROLLED DOCUMENT.		OWN: D. STRAUSSER 05MAR2010	TE Connectivity	
DIMENSIONS:		CHK: D. STRAUSSER 22MAR2010	NAME: ASSEMBLY, HEADER, 35 POSITION, VERTICAL, AMPSEAL WITH FLANGE SEAL	
mm	TOLERANCES UNLESS OTHERWISE SPECIFIED:	APVD: D. STRAUSSER 27APR2010	PRODUCT SPEC: 108-1329	RESTRICTED TO: -
	0 PLC ±	APPLICATION SPEC: 114-16016	SIZE: A1	CAGE CODE: 776231
	1 PLC ±0.2	WEIGHT: 40.29g	SCALE: 1:1	SHEET 2 OF 2
	2 PLC ±	CUSTOMER DRAWING	REV: A15	
	3 PLC ±			
	4 PLC ±			
	ANGLES ±			
	FINISH ±			

单击下面可查看定价，库存，交付和生命周期等信息

[>>TE Connectivity\(泰科\)](#)