

THIS DRAWING IS UNPUBLISHED. RELEASED FOR PUBLICATION
 © COPYRIGHT - By - ALL RIGHTS RESERVED.

LOC	DIST	REVISIONS			
P	LTR	DESCRIPTION	DATE	DWN	APVD
CM	00	E1	REVISED PER ECO-11-004917	11MAR11	RK HMR

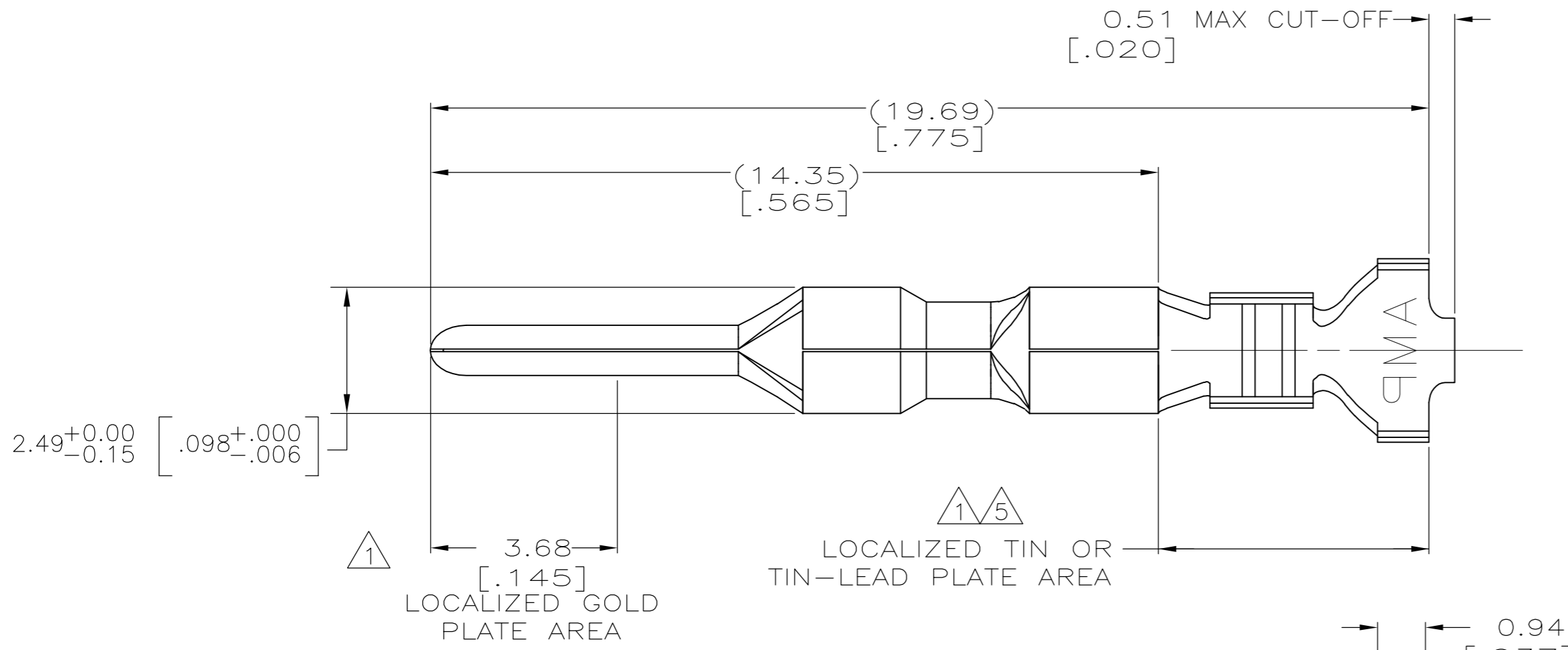

- 1. 0.00076 [.000030] MIN GOLD IN LOCALIZED GOLD PLATE AREA AND 0.00254 [.000100] MIN BRIGHT TIN-LEAD IN LOCALIZED TIN-LEAD PLATE AREA OVER 0.0013 [.000050] MIN NICKEL.
- 2. WIRE RANGE: 0.3 - 0.9MM² (22-18 AWG).
- 3. INSULATION RANGE: 1.50-2.79 [.059-.110] DIA.
- 4. DIMENSIONS IN BRACKETS ARE IN INCHES.
- 5. 0.00076 [.000030] MIN GOLD IN LOCALIZED GOLD PLATE AREA AND 0.00254 [.000100] MIN BRIGHT TIN IN LOCALIZED TIN PLATE AREA OVER 0.0013 [.000050] MIN NICKEL.

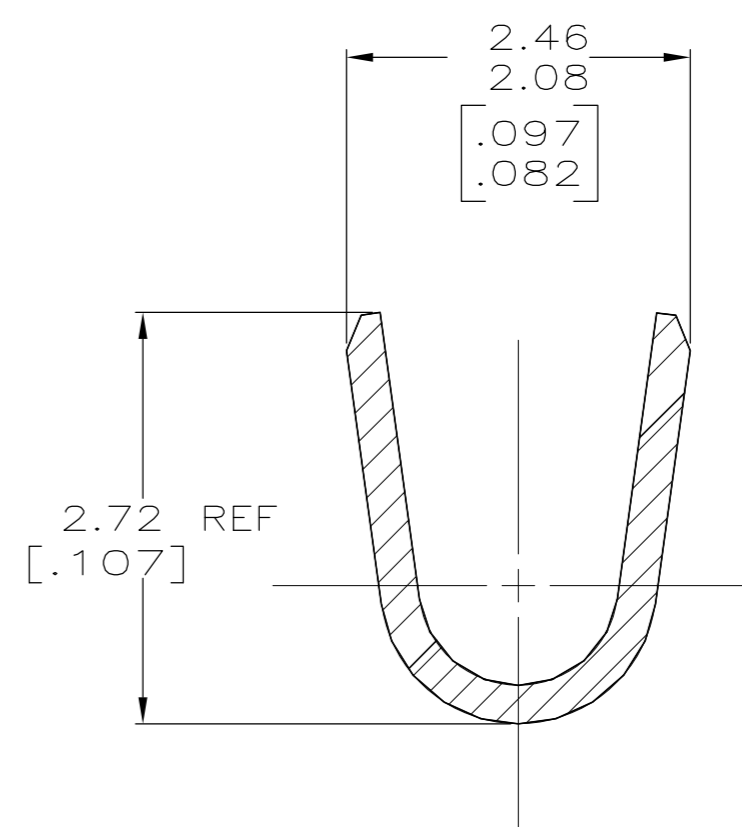
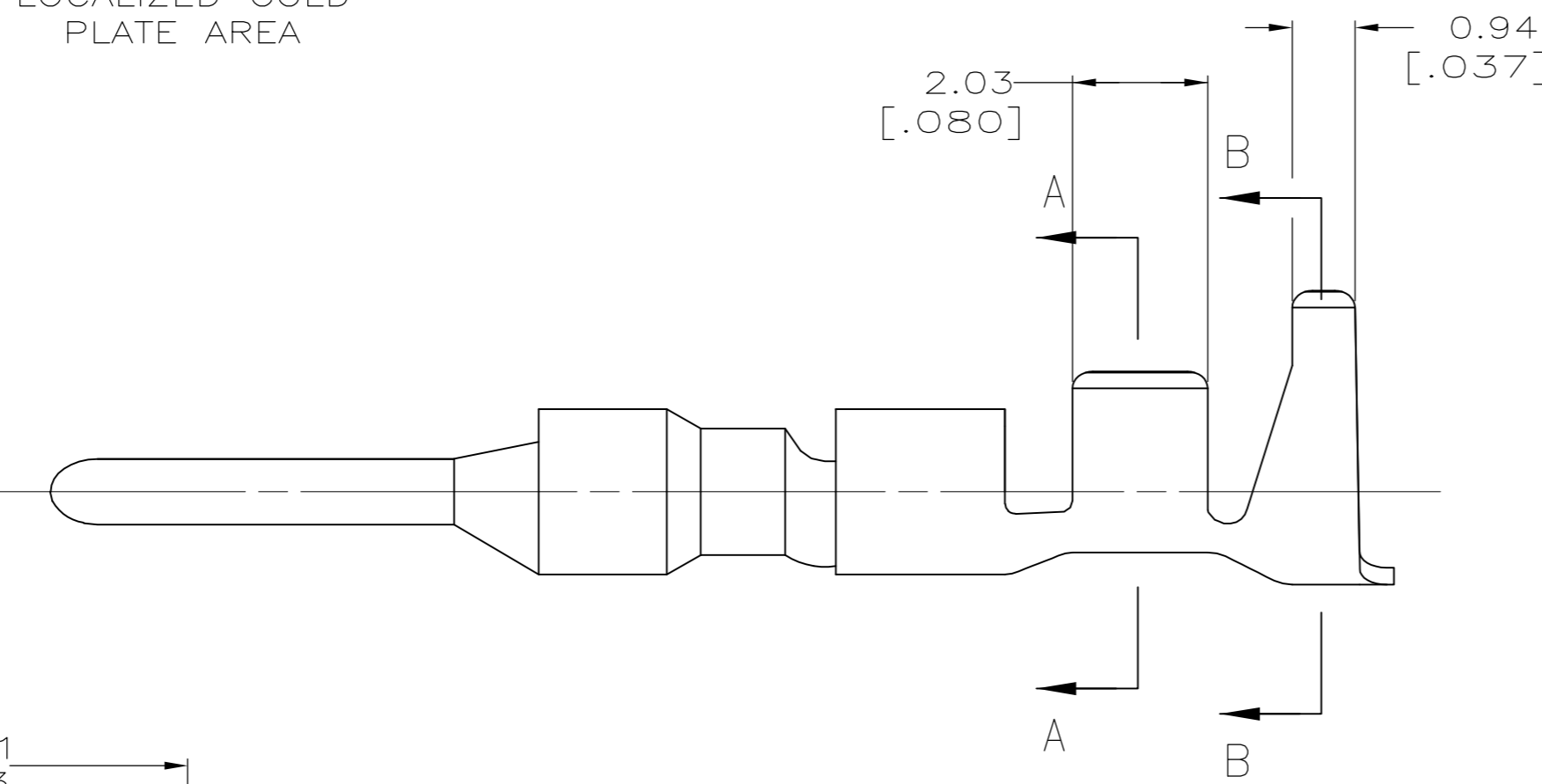

SECTION A-A
SCALE 20:1

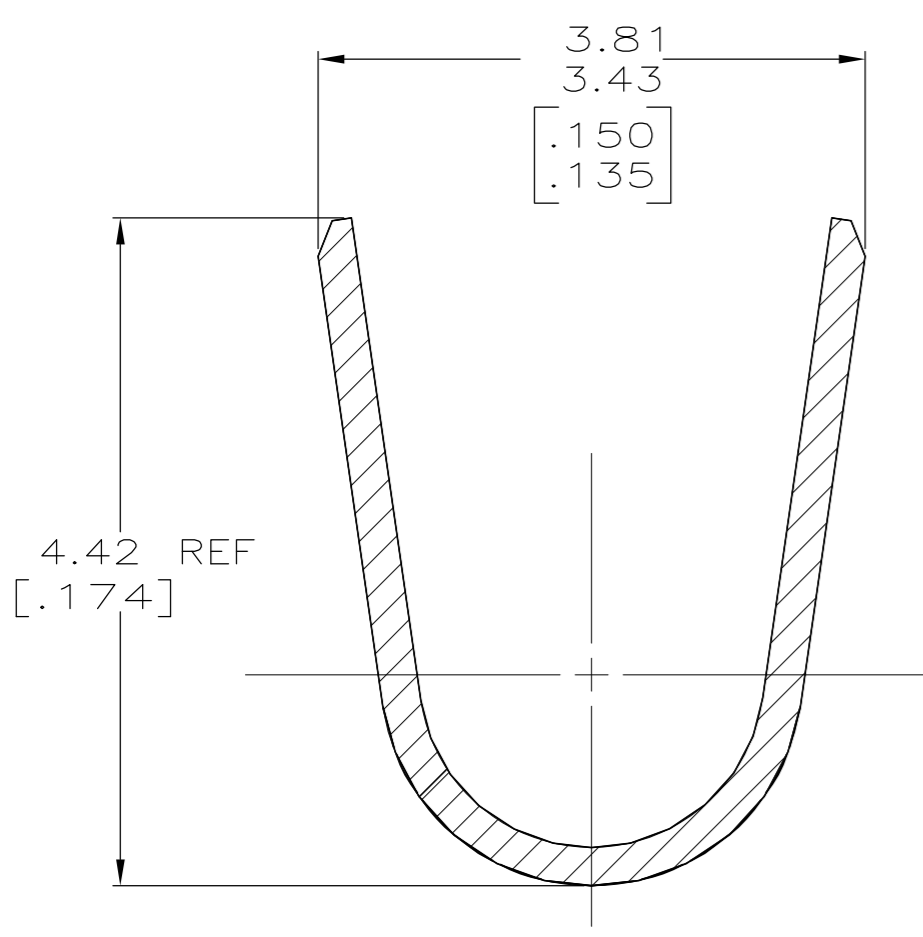

SECTION B-B
SCALE 20:1

FINISH	MATERIAL	PART NUMBER
GOLD 5	0.25 [.010] BRASS	1-794228-0
GOLD 1	0.25 [.010] BRASS	794228-3
PRE-TIN	0.25 [.010] BRASS	794228-1

THIS DRAWING IS A CONTROLLED DOCUMENT.		DWN S. CARPENTER 11AUG2003		
DIMENSIONS: INCHES		CHK C. JONES 11AUG2003		
TOLERANCES UNLESS OTHERWISE SPECIFIED:		APVD C. JONES 11AUG2003	NAME PIN, LOOSE PIECE, MINI UNIVERSAL MATE-N-LOK 2	
0 PLC ± 1 PLC ± 2 PLC ± 3 PLC ± 0.15 [.006] 4 PLC ± ANGLES ±		PRODUCT SPEC	RESTRICTED TO	
MATERIAL SEE TABLE		APPLICATION SPEC	SIZE A2	CAGE CODE 00779
FINISH SEE TABLE		WEIGHT	DRAWING NO C=794228	REV E1
		CUSTOMER DRAWING	SCALE 10:1	SHEET 1 of 1

单击下面可查看定价，库存，交付和生命周期等信息

[>>TE Connectivity\(泰科\)](#)