

REVISIONS					
P	LTR	DESCRIPTION	DATE	DMN	APVD
A2		REVISED PER ECO-17-011927	23AUG2017	RS	KR

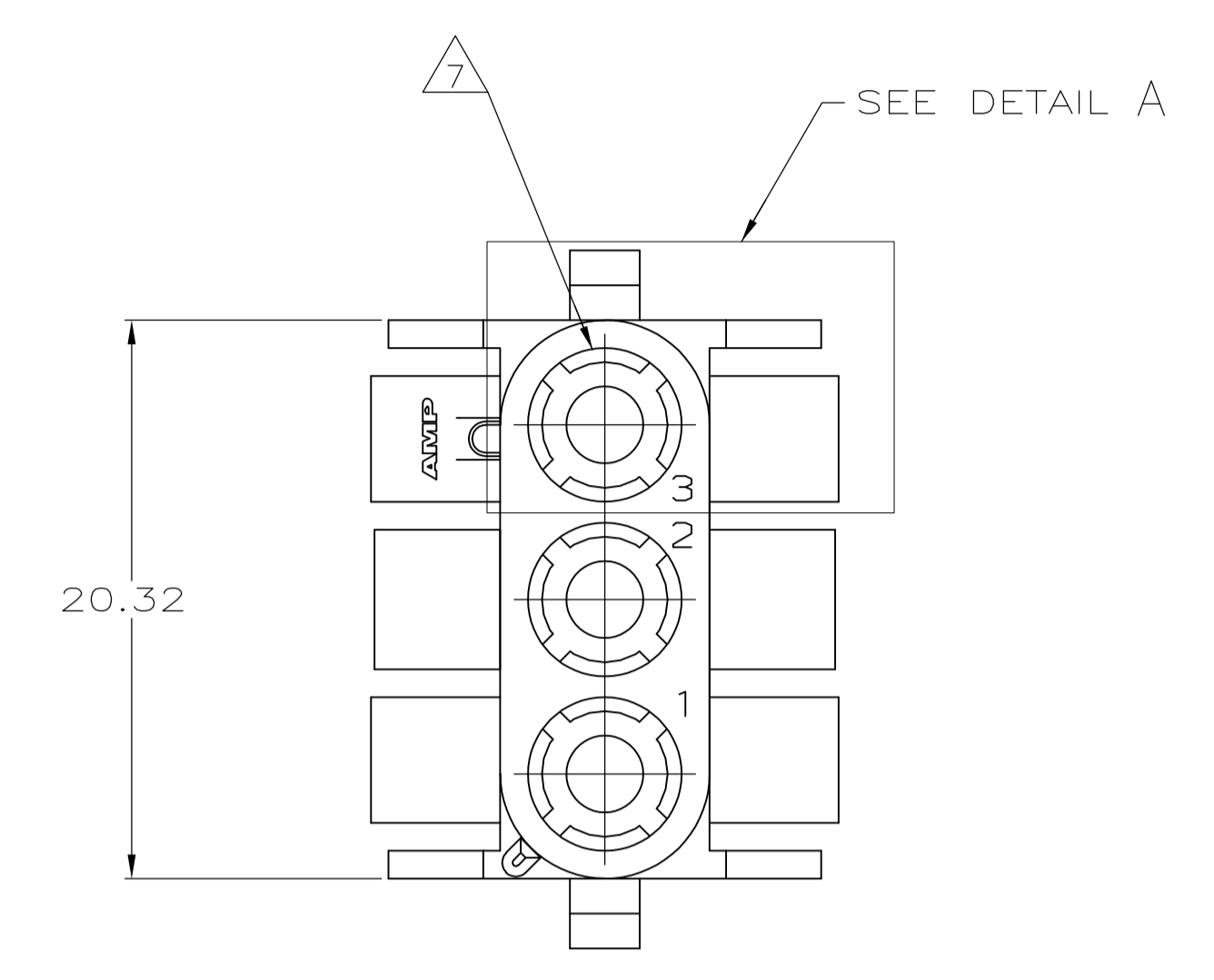

- 1 MATES WITH APPROPRIATE UNIVERSAL MATE-N-LOK™ PLUG.
- 2 RECOMMENDED PANEL THICKNESS 0.76 - 2.29.
- 3 PANEL MUST BE PUNCHED SO THAT THE HOUSING ENTERS THE PANEL IN THE SAME DIRECTION AS THE PUNCH.
- 4 OPTIONAL FOR KEYING HOUSING IN PANEL.
- 5 CIRCUIT NUMBER 1 LOCATION.
- 6 DIMENSIONS SHOWN REPRESENT PRODUCT IN DRY, AS MOLDED CONDITION ADDITIONAL 2% GROWTH DUE TO SUBSEQUENT MOISTURE ABSORPTION MAY OCCUR AND SHOULD BE ACCOUNTED FOR.
- 7 FOUR RIBS EQUALLY SPACED, NO SPECIFIC ORIENTATION, NO RIBS OR SIX RIBS EQUALLY SPACED, NO SPECIFIC ORIENTATION, OPTIONAL.
- 8 UNDERWRITERS RECOGNIZED COMPONENT LOGO 8 AND CSA CERTIFICATION LOGO TO BE LOCATED ONCE EACH ON SIDE OF HOUSING.
- 9 150° C TEMPERATURE RATING FOR THIS HOUSING IS FOR SHORT TERM DURATION. MAX OPERATING TEMPERATURE REMAINS 125° C.
- 10 PHOSPHOR BRONZE CONTACTS SHOULD ALWAYS BE USED WITH THIS HOUSING.

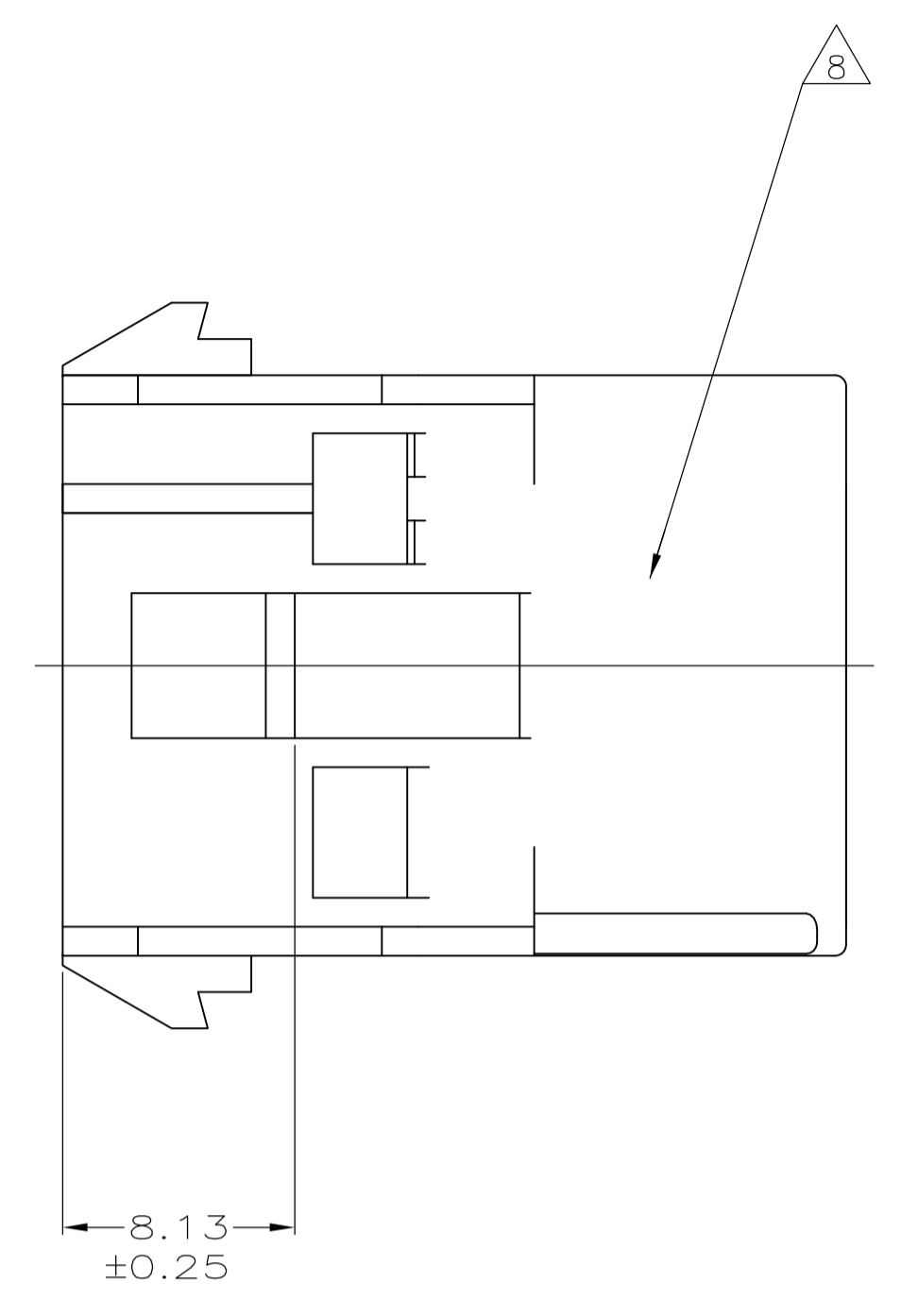
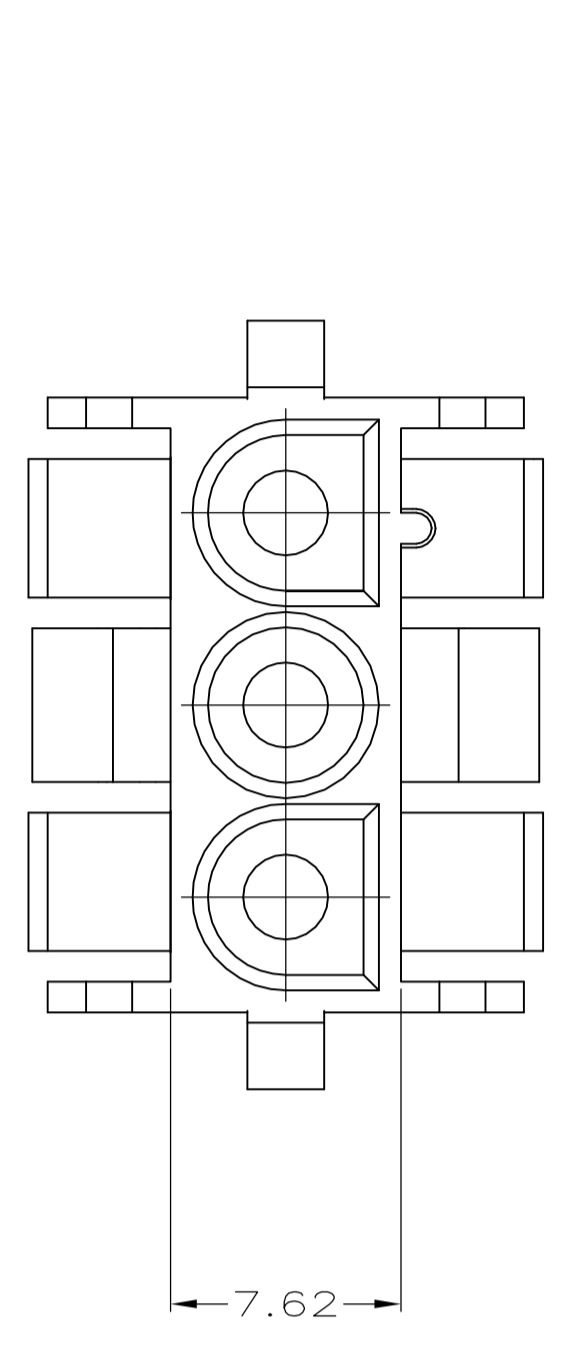
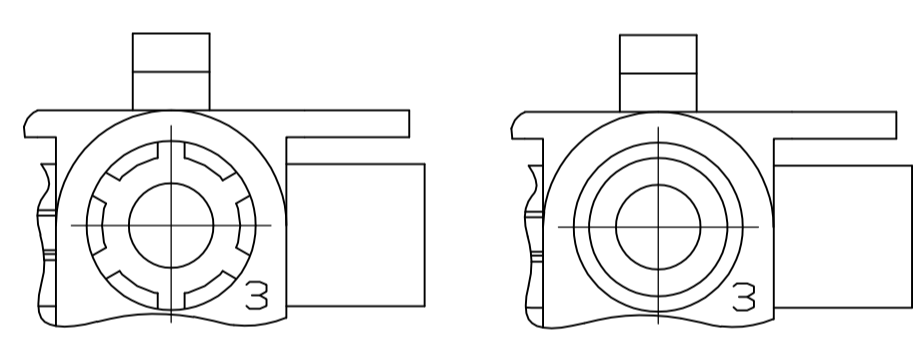

DETAIL A
OPTIONAL CONSTRUCTIONS

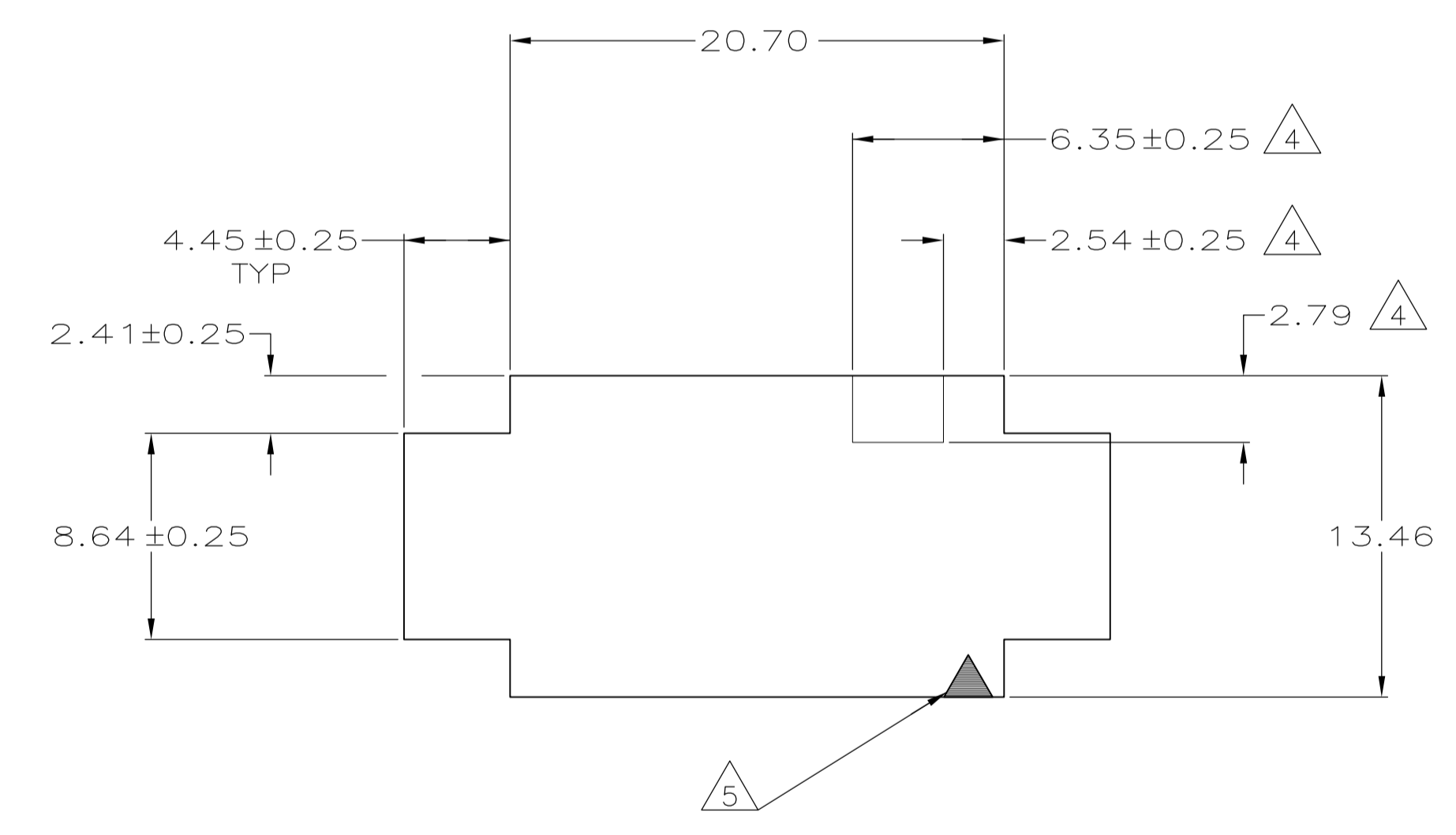
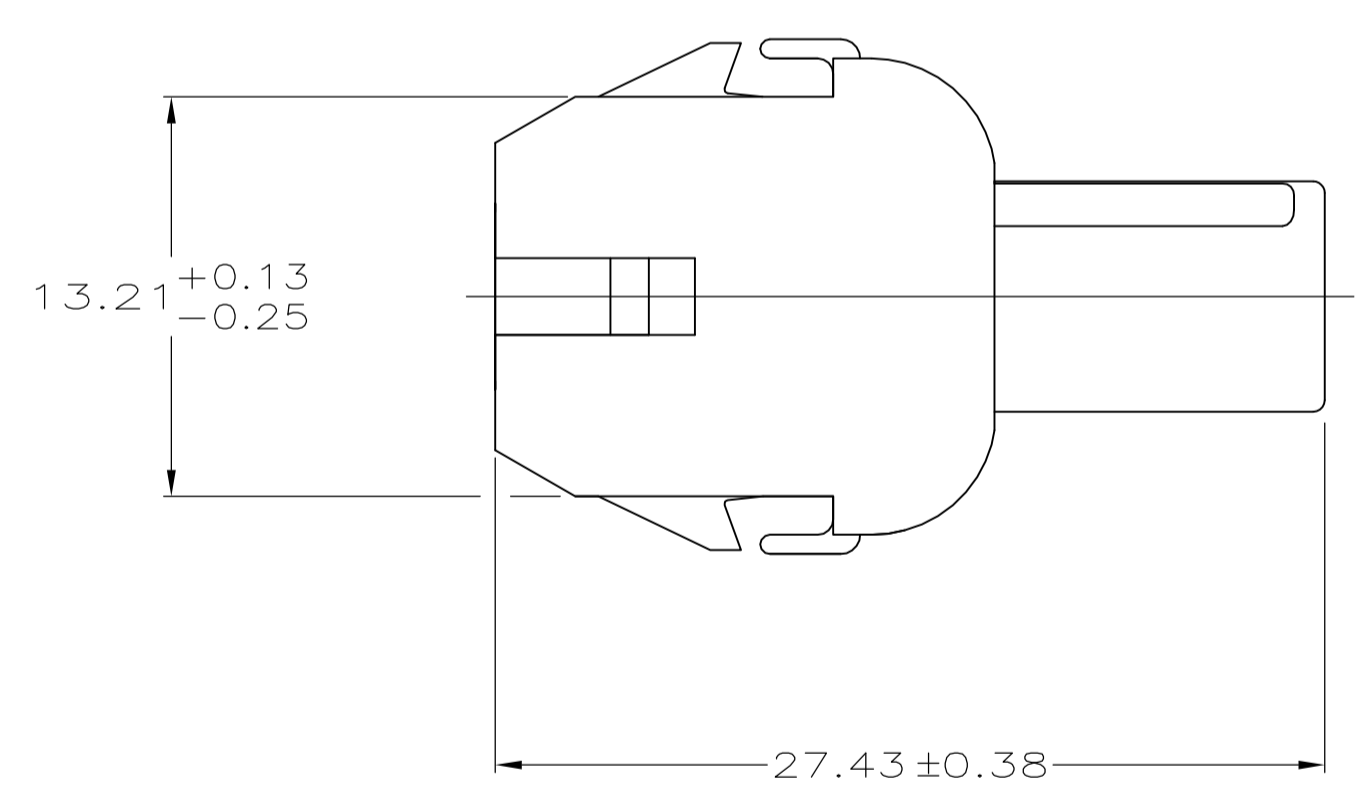

RECOMMENDED PANEL CUT OUT

MM	IN	MM	IN
4.45	.175	27.43	1.080
2.79	.110	20.70	.815
2.54	.100	20.32	.800
2.41	.095	13.46	.530
2.29	.090	13.21	.520
0.76	.030	8.64	.340
0.38	.015	8.13	.320
0.25	.010	7.62	.300
0.13	.005	6.35	.250
MM	IN	MM	IN

CONVERSION TABLE

METRIC

THIS DRAWING IS A CONTROLLED DOCUMENT.

DIMENSIONS: INCHES	TOLERANCES UNLESS OTHERWISE SPECIFIED:	DIN K. WHITAKER 16-MAY-2001	APVD S. RIDGILL 16-MAY-2001	NAME
0 PLC ± -	1 PLC ± -	2 PLC ± -	3 PLC ± 0.13	4 PLC ± -
ANGLES ± -	± 1° 0'			
MATERIAL NYLON,UL 94V-2, HIGH TEMP	FINISH -	WEIGHT 0.000000	A1 00779	794900
CUSTOMER DRAWING		SCALE 4:1	SHEET 1 OF 1	REV A2

BLACK 794900-1
COLOR PART NO

STE TE Connectivity

CAP, 3 CIRCUIT, UNIVERSAL MATE-N-LOK™ TM

单击下面可查看定价，库存，交付和生命周期等信息

[>>TE Connectivity\(泰科\)](#)