

1

1. Scope:**1.1 Contents**

This specification covers the requirements for product performance, test methods and quality assurance provisions of NEXT GENERATION GRACE INERTIA CONNECTOR 3.3

Applicable product description and part numbers are as shown in Appendix 1.

2. Applicable Documents

The following documents form a part of this specification to the extent specified herein. In the event of conflict between the requirements of this specification and the product drawing, the product drawing shall take precedence. In the event of conflict between the requirements of this specification and the referenced documents, this specification shall take precedence.

2.1 TE Specifications:

- A. 109-5000 Test Specification, General Requirements for Test Specification
- B. 501-106094 Qualification Test Report.
(Terminal part number: 1983780-1)
- C. 501-106339 Qualification Test Report.
(Terminal part number: 2318950-1)

2.2 Commercial Standards and Specifications:

- A. MIL-STD-202: Test methods for Electronic and Electrical Components Parts

1. 适用范围:**1.1 内容:**

本规格涵盖新优雅系列 3.3 节距连接器产品的产品性能、测试方法、品质保证等的必要条件与规定。具体适用的产品型号与料号请参见附录 1。

2. 适用文档:

在指定的范围，下面文件组成本规格的一部分。如果本规格要求与产品图纸有冲突或不符合的地方，首先选择产品图纸规格要求；如果参考的文件与本规格要求有冲突或者不符合的地方，首先选择本规格的要求。

2.1 TE 规格:

- A. 109-5000 一般测试方法
- B. 501-106094 产品合格测试报告
(端子料号: 1983780-1)
- C. 501-106339 产品合格测试报告
(端子料号: 2318950-1)

2.2 商用标准与规格:

- A. MIL-STD-202: 电子电气零部件测试方法

1

3. Requirements:**3.1 Design and Construction:**

Product should be of the design, construction and physical dimension specified on the applicable product drawing.

3.2 Materials:

- A. Rec Contact (Crimp Type): Copper Alloy
Contact points: Pre-tin plating or Tin plating
- B. Plug housing:
PA66, Glass fiber filled, UL94-V0
Tracking Index: UL Level 2
- C. TPA:
PA66, Glass fiber filled, UL94-V0
Tracking Index: UL Level 2
- D. Header assembly:
Header Housing: PA66, Glass fiber filled,
UL94-V0
Tracking Index: UL Level 2
Post Contact: Copper Alloy, Pre-tin plating

3. 产品要求:**3.1 设计与结构:**

产品需符合对应产品图纸所要求的设计、结构和尺寸。

3.2 材料:

- A. 母端子（压接类型）：铜合金
接触区表面处理：预镀锡，或镀锡
- B. 公端壳体
PA66，玻纤强化，UL94-V0
CTI 等级：UL -2
- C. 端子保持增强部件 TPA
PA66，玻纤强化，UL94-V0
CTI 等级：UL -2
- D. 母端组件
母端壳体：PA66，玻纤强化，
UL94-V0
CTI 等级：UL -2
针型端子：铜合金，预镀锡

3.3 Ratings:

- A. Voltage Rating: 250V AC/DC
- B. Current Rating: See Fig.1
- C. Temperature Rating: -30°C to 105°C
(Include temperature rising by energized current)
- D. Minimum Rating: 1mV, 1 μA Minimum
- E. Applicable PCB: Thickness 1.6mm
Diameter of the hole:
For Tine:
0.7 +0.1/-0 (Punched Hole)
0.8 ±0.05 (Drilled Hole)
For Boss:
1.4 ±0.05 (Punched hole & Drilled hole)

3.3 规格:

- A. 额定电压: 250V AC/DC
- B. 额定电流: 参见图表-1.
- C. 工作温度: -30°C ~ 105°C
(含通电后产生的温升)
- D. 最小规格: 1mV, 1 μA (最低)
- E. PCB 规格: 板厚: 1.6mm
适用的孔径:
梳齿端子:
0.7 +0.1/-0 (冲裁孔)
0.8 ±0.05 (机钻孔)
定位柱:
1.4 ±0.05 (冲裁孔 及 机钻孔)

3.4 Performance Requirements & Test Description:

The product should be designed to meet the electrical, mechanical and environmental performance requirements specified in Fig. 2. All tests shall be performed in the room temperature unless otherwise specified.

3.4 性能要求及测试描述:

所用产品需满足图表-2 中列出的电气、机械及环境要求。除非另有指定, 所有测试均在室温环境下进行。

Contact 端子	Rec. Contact : 母型端子				
	1983780-1 2318950-1 (assembly with TPA: 2-1971904 -□) 与 TPA: 2-1971904 -□ 装配			1971795-1 * (assembly with TPA: 4-1971904 -□) 与 TPA: 4-1971904 -□ 装配	
Wire Size Pos. 位数	AWG #20	AWG #22	AWG #24	AWG #26	AWG #28
4	4	2.5	2.2	2	1.5
6	4	2.5	2.2	2	1.5
8	4	2.5	2.2	-	-
10	3.5	2.5	2.2	-	-
12	3.5	2.5	2.2	-	-
14	3	2.2	2	-	-

(*) Restricted to the customer: 0791-01246266 (customer code)

(*) 仅适用于客户: 0791-01246266 (客户代码)

Fig-1. 图表-1

3.5 Test requirements and Procedure Summary:

3.5 实验规格及测试规范:

No. 序号	3.5.1	
Test Items 实验项目	Examination of Product	样品检验
Requirements 规格值	Meets requirements of product drawing and TE/AMP specification (114-106094). After test, no corrosion influence performance.	产品及图面需符合 TE/AMP 114-106094 的规格要求。 测试结束后, 没有可影响后续实验的腐蚀现象。
Procedures 试验方法	Visual inspection No physical damage	目视检测, 没有可见物理损伤
Electrical Requirements 电气性能要求		
No. 序号	3.5.2	
Test Items 实验项目	Terminal Resistance (Low Level Contact Resistance)	端子阻抗 (低电平接触电阻 LLCR)
Requirements 规格值	10 mΩ Max. (Initial) 20 mΩ Max. (Final)	10 mΩ 最大. (初始) 20 mΩ 最大. (最终)
Procedures 试验方法	Subject mated contact assembled in housing to 20mV Max. open circuit at 10mA. Take the resistance of the wire only away from measurement. Fig. 6 TE Spec. 109-5311-1	端子组装于壳体中, 并相互保持闭合接通, 在开路电压 20mV、闭路电流 10mA 的条件下测试。测量时排除电线电阻。 参见图表 6。 TE 规格: 109-5311-1
No. 序号	3.5.3	
Test Items 实验项目	Insulation Resistance	绝缘阻抗
Requirements 规格值	1000 MΩ Min. (Initial) 500 MΩ Min. (Final)	1000 MΩ 最小. (初始) 500 MΩ 最小. (最终)
Procedures 试验方法	Impressed voltage 500 V DC. Test between adjacent circuits and between the surface of housing and contact of mate connectors. TE Spec: 109-5302 MIL-STD-202, method 302, Condition B	施加 500V DC 直流电压; 在相邻电路之间以及在壳体表面和闭合接通的端子之间进行测量。 TE 规格: 109-5302 MIL-STD-202, 实验方法 302, 条件 B

Fig. 2 图表-2 (To be Continued 后续)

No. 序号	3.5.4	
Test Items 实验项目	Dielectric withstanding Voltage	绝缘耐压
Requirements 规格值	Neither creeping discharge nor flashover shall occur. Current leakage: 5 mA Max.	无爬电放电及放电电弧出现。 漏电电流: 5mA 最大。
Procedures 试验方法	1.5kVAC for 1 minute. Test between adjacent circuits and between the surface of housing and contact of mated connectors.	施加 1.5kVAC 交流电压 1 分钟。 在相邻电路之间以及在壳体表面和闭合接通的端子之间进行测量。
No. 序号	3.5.5	
Test Items 实验项目	Temperature Rising	温升
Requirements 规格值	30°C Max. under loaded specified current	加载规定电流条件下, 最大 30°C
Procedures 试验方法	Measure temperature rising by energized current. Subject measurement must do at the place of no influence from convection of air. And contacts assembled in housing all of circuits. The thermocouple attach to the contact of center circuit number. Fig. 1, 6 TE Spec. 109-5310	接通电流条件下测量温升。 需子啊没有空气对流的环境下测量样品。 样品组装于壳体中, 并接通所有电路。 热电偶贴附在所有电路数的中间端子上。 参照图表 1, 6 TE 规格: 109-5310
Mechanical Requirements 机械性能要求		
No. 序号	3.5.6	
Test Items 实验项目	Vibration (Low Frequency)	振动 (低频)
Requirements 规格值	No electrical discontinuity greater than 1 μ s shall occur. LLCR 20 m Ω Max. (Final)	振动中, 电路断开时间不得大于 1 μ s. LLCR 20m Ω 最大. (最终)
Procedures 试验方法	Subject mated connectors to 10-55-10 Hz traversed in 1 minute at 1.52mm amplitude, 2 hours each of 3 mutually normal planes. 100 mA Applied. Fig. 7 TE Spec. 109-5201 MIL-STD-202. Method 201A	在 3 个相互垂直的平面上对闭合连接的样品施加 1.52mm 振幅的振动, 其频率在 1 分钟内 10-55-10Hz 循环, 时长 2 小时。 施加电流: 100mA. 参照图表 7 TE 规格: 109-5201 MIL-STD-202, 实验方法 201A

Fig. 2 图表-2 (To be Continued 后续)

No. 序号	3.5.7	
Test Items 实验项目	Shock	冲击
Requirements 规格值	No electrical discontinuity greater than 1 μ s shall occur. LLCR 20 m Ω Max. (Final)	振动中, 电路断开时间不得大于 1 μ s. LLCR 20m Ω 最大. (最终)
Procedures 试验方法	Mated conn. (50G) Waveform: half-sine curve Duration: 11ms Number of drops: 3 drops each to normal and reversed directions of X, Y and Z axes, totally 18 drops TE Spec. 109-5208, See Fig.7 MIL-STD-202, Method 213, Condition A	连接器: 保持接通闭合 (50G) 波形: 半正弦波 冲击次数: 共 18 次, X, Y, Z 三个面正交及平行冲击各三次; TE 规格: 109-5208, 参见图表 7 MIL-STD-202, 试验方法 213, 条件 A
No. 序号	3.5.8	
Test Items 实验项目	Connector mating / unmating Force	连接器插拔力
Requirements 规格值	Mating force: (5.88 \times Pos.) N Max. (600 \times Pos.) gf Max. Unmating force: (0.58 \times Pos.) N Min. (1 st) (60 \times Pos.) gf Min. (1 st) (0.29 \times Pos.) N Min. (30 th) (30 \times Pos.) gf Min. (30 th)	插入力: (5.88 \times Pos.) N 最大. (600 \times Pos.) gf 最大. 拔出力: (0.58 \times Pos.) N 最小. (初次) (60 \times Pos.) gf 最小. (初次) (0.29 \times Pos.) N 最小. (第 30 次) (30 \times Pos.) gf 最小. (第 30 次)
Procedures 试验方法	operation speed: 100mm/min. Measure the force required to mate / unmate connectors without Housing Lock	操作速度: 100mm/分钟; 去除壳体间的锁扣, 测量连接器的插拔力。
No. 序号	3.5.9	
Test Items 实验项目	Rec. Contact Insertion Force	母型端子插入力
Requirements 规格值	8.82N (0.9 kgf) Max. per contact	8.82N (0.9 kgf) 最大 (单个端子)
Procedures 试验方法	Measure the force required to insert contact into housing. TE Spec. 109-5211	测量母型端子插入壳体时的力; TE 规格: 109-5211

Fig. 2 图表-2 (To be Continued 后续)

No. 序号	3. 5. 10					
Test Items 实验项目	Rec. Contact Retention Force			母型端子保持力		
Requirements 规格值	1).19.8N(2kgf) Min. without TPA for all Wire; 2). 40N Min, with TPA for AWG20,AWG22,AWG24 wire.			1), 不带 TPA, 全部线型: 19. 8N (2kgf) 最 小. 2), 带 TPA, AWG20,AWG22,AWG24 wire.: 40N MinC		
Procedures 试验方法	Apply an axial pull-off load to crimped wire. Operation speed: 100mm/min. TE Spec. 109-5210			在压接后的导线上施加轴向拉力。 操作速度: 100mm/分钟。 TE 规格: 109-5210		
No. 序号	3. 5. 11					
Test Items 实验项目	Contact Mate / Unmating Force			端子插拔力		
Requirements 规格值	Mate: 5. 88 (600gf) Max. (1 st ~30 th) Unmate: 0. 34N (35gf) Min. (1 st) 0. 25N (25gf) Min. (30 th)			插入力: 5. 88 (600gf) 最大. (1~30 次) 拔出力: 0. 34N (35gf) 最小. (第 1 次) 0. 25N (25gf) 最小. (第 30 次)		
Procedures 试验方法	Measured by gage tab (Fig. 8) and operation speed 100 mm/min TE Spec. 109-5206			使用夹具测量(图表. 8), 操作速度: 100mm/ 分钟。 TE 规格: 109-5206		
No. 序号	3. 5. 12					
Test Items 实验项目	Crimp Tensile Strength			压接强度		
Requirements 规格值	Wire Size		Crimp Tensile(min.)	线型		强度(最小)
	mm ²	(AWG)	N(kgf)	mm ²	(AWG)	N(kgf)
	0. 08	28	9. 8(1)	0. 08	28	9. 8(1)
	0. 14	26	19. 6(2)	0. 14	26	19. 6(2)
	0. 22	24	29. 4(3)	0. 22	24	29. 4(3)
	0. 31	22	49(5)	0. 31	22	49(5)
0. 51	20	58. 8 (6)	0. 51	20	58. 8 (6)	
Procedures 试验方法	Apply an axial pull-off load to crimped wire of contact secured on the tester. Operation speed: 100mm/min. Subject take insulation barrel away. TE Spec. 109-5205			将压接过的线材和端子固定在测量设备上, 施加轴向拉力。 操作速度: 100mm/分钟。 去除绝缘压接部分。 TE 规格: 109-5205		
No. 序号	3. 5. 13					
Test Items 实验项目	Durability (Repeated Mate / Unmating)			耐久性(重复插拔)		
Requirements 规格值	20 mΩ Max.			20 mΩ 最大.		
Procedures 试验方法	No. of Cycles: 30 cycles			循环次数: 30 个循环.		

Fig. 2 图表-2 (To be Continued 后续)

No. 序号	3.5.14	
Test Items 实验项目	Housing Locking Strength	壳体锁扣力
Requirements 规格值	24.5N (2.5kgf) Min.	24.5N (2.5kgf) 最小..
Procedures 试验方法	Measure connector locking strength. Operation speed: 100 mm/min. TE Spec: 109-5210	测量壳体之间锁扣力。 操作速度: 100mm/分钟。 TE 规格: 109-5210
No. 序号	3.5.15	
Test Items 实验项目	Post Contact Retention Force	针型端子保持力
Requirements 规格值	19.6N (2.0kgf) Min	19.6N (2.0kgf) 最小
Procedures 试验方法	Measure post retention force. Operation speed: 100mm/min.	测量针型端子保持力。 操作速度: 100mm/分钟。
No. 序号	3.5.16	
Test Items 实验项目	Hammering shocks	摆锤冲击
Requirements 规格值	20 mΩ Max. (Final) No evidence of abnormalities	20 mΩ 最大. (最终) 无异常。
Procedures 试验方法	Mated connectors to under 10000 cycles of repeated hammering shocks Hammering height: 80mm Hammering weight: 50g Hammering speed: 1 cycle / sec. DC 10V, 1mA applied Fig.9	连接器闭合连接, 10000 次重复摆 锤冲击; 摆锤高度: 80mm; 摆锤重量: 50g; 冲击速度: 1 次/秒; 施加直流 DC 10V, 1mA, 参见图表 9

Fig. 2 图表-2 (To be Continued 后续)

Environmental Requirements 环境性能要求		
No. 序号	3. 5. 17	
Test Items 实验项目	Thermal shock	热冲击
Requirements 规格值	20 mΩ Max. (Final)	20 mΩ 最大. (最终)
Procedures 试验方法	Mated connector -55°C/30 min., 85°C/30min. Making this a cycle, repeat 25 cycles. TE Spec. 109-5103 Condition A MIL-STD-202 Method 107-1 Condition A-1 This measurement is held after being left indoor for 3 hours.	连接器闭合连接: -55°C/30 分钟、85°C/30 分钟为一个循环, 重复 25 个循环; TE 规格: 109-5103 条件 A MIL-STD-202 方法 107-1 条件 A-1 实验前试品需在室温下放置 3 小时
No. 序号	3. 5. 18	
Test Items 实验项目	Humidity-Temperature Cycling	温湿循环
Requirements 规格值	Dielectric withstanding voltage 1.5kV AC 1 minute Insulation resistance (final) 500 MΩ Min. Termination resistance 20 mΩ Max. (Final)	绝缘耐压 1.5kV AC 交流 1 分钟 绝缘阻抗(最终)500 MΩ (最小). 端子阻抗(最终)20 mΩ (最大).
Procedures 试验方法	Mated connector, 25~65°C, 80~90% R.H. 10 cycles TE Spec. 109-5106 MIL-STD-202, Method 106 Condition D The measurement is held after being left indoor for 3 hours. 1cycle=24hours	连接器闭合连接, 25~65°C, 80~90%R.H. (相对湿度)10 个循环 TE 规格: 109-5106 MIL-STD-202 方式 106 条件 D 实验前试品需在室温下放置 3 小时 1 个循环=24 小时
No. 序号	3. 5. 19	
Test Items 实验项目	Salt spray	盐雾
Requirements 规格值	20 mΩ Max. (Final) No corrosion influence performance	20 mΩ 最大. (最终) 无影响性能的腐蚀。
Procedures 试验方法	Subject mated connectors to 5±1% salt concentration for 48 hours; MIL-STD-202, Method 101, Condition B The measurement is held after remove the salt and dry up indoor.	连接器闭合连接, 置于 5±1%浓度的盐雾中 48 小时; MIL-STD-202 方式 101 条件 B 测量需在试样从盐雾环境中取出并干燥之后。

Fig. 2 图表-2 (To be Continued 后续)

No. 序号	3. 5. 20	
Test Items 实验项目	Heating Aging	热老化
Requirements 规格值	20 mΩ Max. (Final)	20 mΩ 最大. (最终)
Procedures 试验方法	Mated connector, 105±2°C, Duration 96hours TE spec. 109-5104-3 Condition A The measurement is held after being left indoor for 3 hours.	连接器闭合连接, 105±2°C, 96 小时 TE 规格: 109-5104-3 条件 A 试样需在室温放置 3 小时之后测试
No. 序号	3. 5. 21	
Test Items 实验项目	Resistance to Cold	耐寒性
Requirements 规格值	20 mΩ Max. (Final)	20 mΩ 最大. (最终)
Procedures 试验方法	Mated connectors, -30±2°C, Duration 96hours TE spec. 109-5108-3 Condition D	连接器闭合连接, -30±2°C, 96 小时 TE 规格: 109-5108-3 条件 D
No. 序号	3. 5. 22	
Test Items 实验项目	H ₂ S	H ₂ S (耐酸性)
Requirements 规格值	20 mΩ Max. (Final) No corrosion influence performance	20 mΩ 最大. (最终) 无影响性能的腐蚀。
Procedures 试验方法	Mated connector, 3±1ppm, 40±2°C, Duration 96hours	连接器闭合连接, 3±1ppm, 40±2°C, 96 小时
No. 序号	3. 5. 23	
Test Items 实验项目	NH ₃ Gas	NH ₃ 气体 (耐碱性)
Requirements 规格值	20 mΩ Max. (Final) No corrosion influence performance	20 mΩ 最大. (最终) 无影响性能的腐蚀。
Procedures 试验方法	Mated connector is put into atmosphere that rated 25 mL/L of 3% NH ₃ for 7 hours	连接器闭合连接, 放置于浓度为 25 mL/L 的 3% 的 NH ₃ 的空气中 7 小时

Fig. 2 图表-2 (To be Continued 后续)

No. 序号	3. 5. 24	
Test Items 实验项目	Solderability	可焊性
Requirements 规格值	Wet Solder Coverage: 95% min.	沾锡覆盖率: 95% 最小.
Procedures 试验方法	Eutectic solder Solder temperature: $230 \pm 5^{\circ}\text{C}$ Immersion Duration: 3 ± 0.5 sec. Lead-free solder (Sn-Ag-Cu) Solder temperature: $240 \pm 5^{\circ}\text{C}$ Immersion Duration: 3 ± 0.5 sec. MIL-STD-202 Method 208	共晶焊锡 焊接温度: $230 \pm 5^{\circ}\text{C}$ 浸入时间: 3 ± 0.5 秒 无铅焊料 (Sn-Ag-Cu) 焊接温度: $240 \pm 5^{\circ}\text{C}$ 浸入时间: 3 ± 0.5 秒 MIL-STD-202 方式 208
No. 序号	3. 5. 25	
Test Items 实验项目	Resistance to soldering Heat	耐焊接热
Requirements 规格值	No physical damage shall occur	无物理损伤
Procedures 试验方法	Test connector on PCB. Solder temperature: $260 \pm 5^{\circ}\text{C}$ Immersion Duration: 10 ± 0.5 sec. TE spec. 109-5204, Condition B MIL-STD-202 Condition 210 In case of manual soldering iron, apply it as $360 \pm 10^{\circ}\text{C}$ for 3 ± 0.5 seconds without forcing pressure to affect the tine of contact.	连接器在 PCB 上测试。 焊接温度: $260 \pm 5^{\circ}\text{C}$ 浸入时间: 10 ± 0.5 秒 TE 规格: 109-5204 条件 B MIL-STD-202 条件 210 如使用手工烙铁焊接, 则施加 $360 \pm 10^{\circ}\text{C}$ 的温度 3 ± 0.5 秒, 在齿梳 上不施加力。

Fig. 2 图表-2 (To be Continued 后续)

*Product must be without rust, corrosion, transformation, crack and discoloration.

试品实验前需确保无锈蚀、腐蚀、变形、破裂及褪色污染。

3.6 Product Qualification Test Sequence

3.6 产品认证实验顺序

Test or Examination	实验项目	Test Group 实验分组									
		1	2	3	4	5	6	7	8	9	
		Test Sequence (a) 实验顺序									
Confirmation of Product	试品确认检查	1, 3	1, 4	1, 3	1, 3	1, 3	1, 4	1, 7	1, 7	1, 4	
Termination resistance (Low Level)	端子阻抗 LLCR (低电平接触电阻)							2, 4, 6	3, 6	2, 5	
Dielectric withstanding Voltage	绝缘耐压						3				
Insulation Resistance	绝缘阻抗						2				
Temperature Rising	温升					2					
Vibration (Low Frequency)	振动(低频)							5			
Physical Shock	冲击							3			
Connector Mating Force	连接器插入力								2		
Connector Unmating Force	连接器拔出力								4		
Rec. Contact Insertion Force	母型端子插入力				2						
Contact Mating Force	端子插入力		2								
Contact Unmating Force	端子拔出力		3								
Crimping Tensile Strength	压接拉伸强度	2									
Durability (Repeated Mating/unmating)	耐久性 (重复插拔)								5		
Housing Locking Strength	壳体锁扣力			2							
NH ₃	NH ₃ (耐碱性)										
Humidity-Temperature Cycling	温湿循环										
H ₂ S	H ₂ S(耐酸性)										
Thermal Shock	热冲击									3	
Salt Spray	盐雾										
Resistance to Cold	耐寒性										
Rec.Contact Retention Force	母型端子保持力						5				
Heat Aging	热老化										
Post Retention Force	针型端子保持力										
Solderability	可焊性										
Resistance to Soldering Heat	耐焊接热										
Hammering Shocks	摆锤冲击										

(a) Number indicate the sequence in which the tests are performed;

(a) 表格内数字指定实验执行顺序;

Fig. 3(1/2) 图表 3 (1/2)

Test or Examination	实验项目	Test Group 实验分组									
		10	11	12	13	14	15	16	17	18	19
		Test Sequence (a) 实验顺序									
Confirmation of Product	试品确认检查	1, 4	1, 4	1, 4	1, 4	1, 4	1, 4	1, 3	1, 3	1, 3	1, 4
Termination resistance (Low Level)	端子阻抗 LLCR (低电平接触电阻)	2, 5	2, 5	2, 5	2, 5	2, 5	2, 5				2, 5
Dielectric withstanding Voltage	绝缘耐压	7									
Insulation Resistance	绝缘阻抗	6									
Temperature Rising	温升										
Vibration (Low Frequency)	振动(低频)										
Physical Shock	冲击										
Connector Mating Force	连接器插入力										
Connector Unmating Force	连接器拔出力										
Rec. Contact Insertion Force	母型端子插入力										
Contact Mating Force	端子插入力										
Contact Unmating Force	端子拔出力										
Crimping Tensile Strength	压接拉伸强度										
Durability (Repeated Mating/unmating)	耐久性 (重复插拔)										
Housing Locking Strength	壳体锁扣力										
NH ₃	NH ₃ (耐碱性)						3				
Humidity-Temperature Cycling	温湿循环	3									
H ₂ S	H ₂ S(耐酸性)					3					
Thermal Shock	热冲击										
Salt Spray	盐雾		3								
Resistance to Cold	耐寒性				3						
Rec.Contact Retention Force	母型端子保持力										
Heat Aging	热老化			3							
Post Retention Force	针型端子保持力							2			
Solderability	可焊性								2		
Resistance to Soldering Heat	耐焊接热									2	
Hammering Shocks	摆锤冲击										3

(a) Number indicate the sequence in which the tests are performed;

(a) 表格内数字指定实验执行顺序;

Fig. 3(2/2) 图表 3 (2/2)

4. Quality Assurance Provisions:

4. 品质保障条件:

4.1 Test Conditions:

4.1 测试条件:

Unless otherwise specified, all the test shall be performed in any combination of the following test conditions.

除非特殊指定, 所有实验均在以下表格列出的环境条件下执行。

Temperature	温度	15~35°C
Relative Humidity	相对湿度	45~75%
Atmospheric Pressure	气压	86.6~106.6kPa

Fig.4. 图表 4

4.2 Tests:

4.2 实验:

4.2.1 Test Specimens:

4.2.1 实验样品:

The test specimens to be employed for tests shall be conforming to the requirements specified in the applicable product drawings. The crimped contacts shall be prepared in accordance with the requirements of applicable Specifications: 114-106094 Crimping Next Generation Grace Inertia Connector 2.5 on the wires specified in Fig. 5 of this specification.

实验所用样品均需符合对应图纸规定之要求。用图表 5 中列出的线型进行端子压接时需符合对应压接规范 114-106094: 新优雅系列 3.3 节距连接器 压接规格 之要求的规定。

4.2.2 Applicable Wires:

4.2.2 适用线型:

The wires to be used for crimping the samples for performance testing shall be conforming to the requirements specified in Fig.5.

对应试品压接端子的线型应符合图表 5 中所示的规格要求。

Calculated Cross-sectional Area (mm ²) 计算截面直径	AWG 线规号	Diameter of a Conductor (mm) 单根导线线直径	Number of Conductors 单根导线数	Insulation Outer Diameter (mm) 绝缘外径
0.08	28	0.12	7	0.9
0.14	26	0.16	7	1.0
0.22	24	0.16	11	1.4
0.31	22	0.16	17	1.58
0.53	20	0.18	21	1.9

Fig.5 图表 5

Wire-to-Board Termination Type(线-板型连接端子):

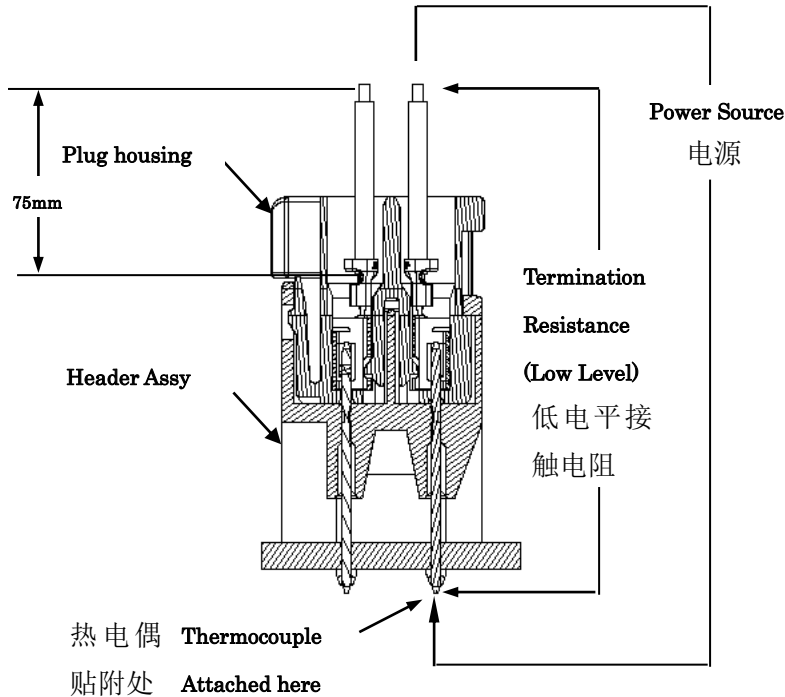

* Take the resistance of 75mm wire only away

* 测定值不含 75mm 电线阻抗

Fig.6 Terminal Resistance (Low Level) and Temperature Rising Vs. Current Measuring Methods

图表 6. 端子阻抗(低电平接触电阻)、温升及电流测试方法

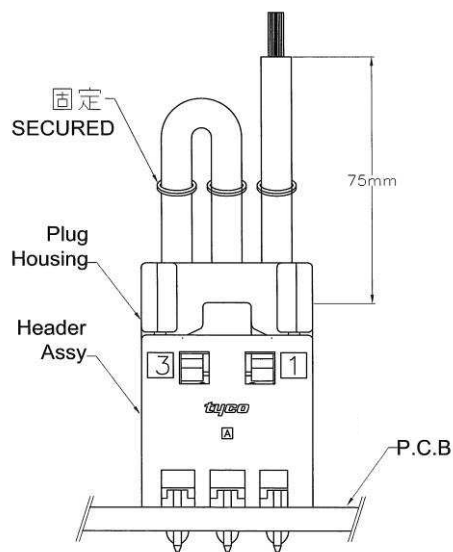

Fig.7 Connector Mounting Methods of Low Frequency Vibration and Physical Shock Test

图表 7. 连接器低频振动及冲击测试与固定方式

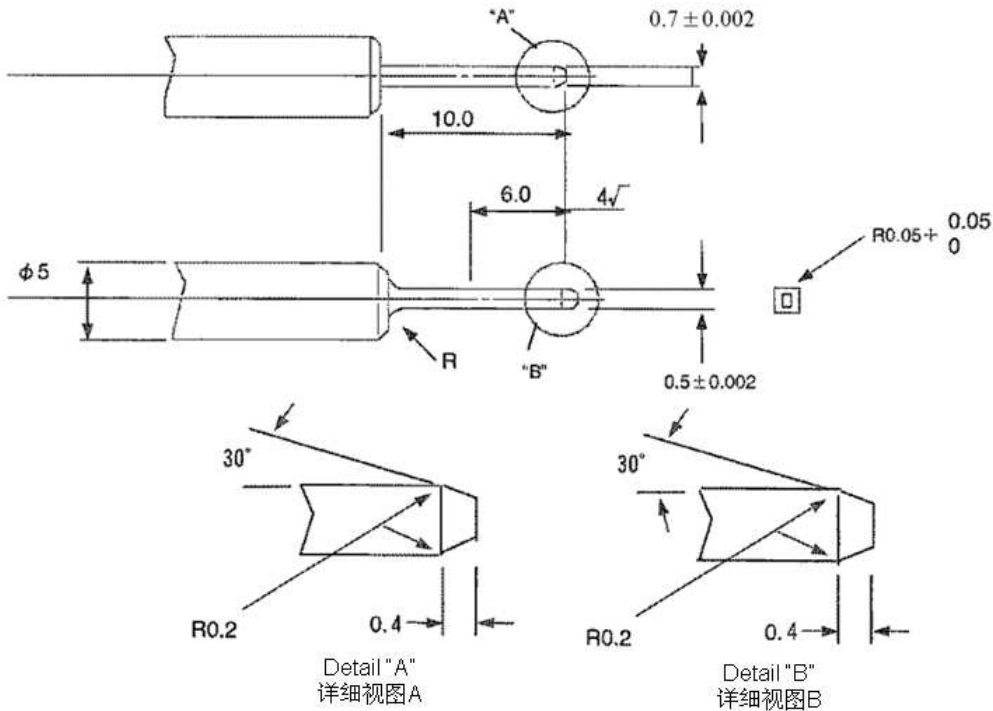

Fig.8 Gage Design for Contact Mating/Unmating Force Tests

图表 8 端子插拔力测试用量规规格

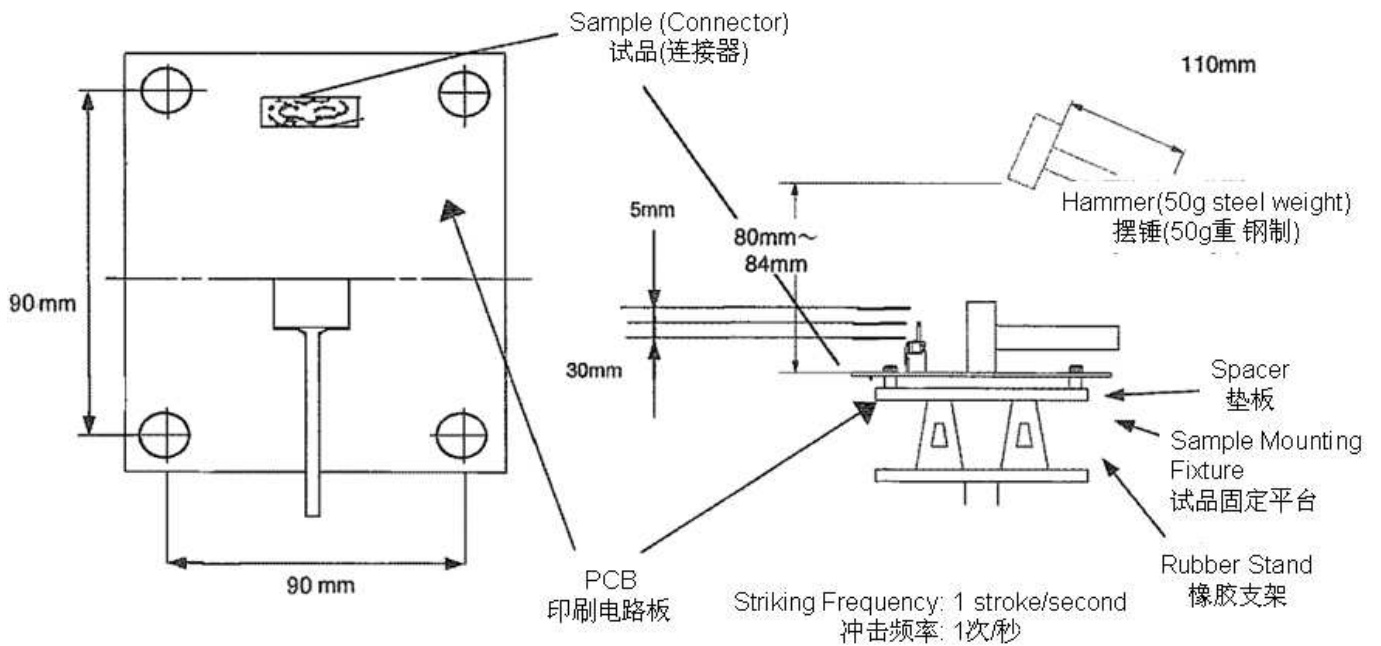

Fig.9 Hammering Shock Test

图表 9. 摆锤冲击测试

Appendix 1 附表 1

Part Number 料号	Remarks
2-1971904 -□	TPA, (for contact 1983780 -1) (与端子 1983780-1 装配)
* 4-1971904 -□	TPA, (for contact 1971795-1) (与端子 1971795-1 装配)
□- 1971905 -□	Plug housing
□-1971906 -□	Header Assembly
1983780 -1 2318950-1	Rec contact, (crimping with AWG20, AWG22, AWG24 WIRE) 母型端子 (压接 AWG20,AWG22,AWG24 导线)
* 1971795-1	Rec contact, (crimping with AWG26, AWG28) 母型端子 (压接 AWG26,AWG28 导线)

(*) Restricted to the customer: 0791-01246266 (customer code)

仅适用于客户: 0791-01246266 (客户代码)

单击下面可查看定价，库存，交付和生命周期等信息

[>>TE Connectivity\(泰科\)](#)