

PRODUCT SPECIFICATION

1. SCOPE

1.1. Content

This specification covers performance, tests and quality requirements for AMP* PDS (Power Distribution System) 125 Bus Plug connector.

1.2. Qualification

When tests are performed on subject product line, procedures specified in AMP 109 series specifications shall be used. All inspections shall be performed using applicable inspection plan and product drawing.

2. APPLICABLE DOCUMENTS

The following documents form a part of this specification to the extent specified herein. In the event of conflict between requirements of this specification and product drawing, product drawing shall take precedence. In the event of conflict between requirements of this specification and referenced documents, this specification shall take precedence.

2.1. AMP Documents

- A. 109-1: General Requirements for Test Specifications
- B. 109 Series: Test Specifications as indicated in Figure 1. (Comply with MIL-STD-202, MIL-STD-1344 and EIA RS-364)
- C. Corporate Bulletin 401-76: Cross-reference between AMP Test Specifications and Military or Commercial Documents
- D. 114-2111: Bus Bar Series 125F & 125F2 Connectors
- E. 501-166: Test Report

3. REQUIREMENTS

3.1. Design and Construction

Product shall be of design, construction and physical dimensions specified on applicable product drawing.

3.2. Material

- A. Contact: Copper alloy, silver over nickel, lubricated
- B. Housing: Antioverstress plate, stainless steel
- C. Hardware: Customer supplied, stainless steel

*Trademark of AMP Incorporated

Product Code: 1080

COPYRIGHT 1988 BY AMP INCORPORATED ALL INTERNATIONAL RIGHTS RESERVED

| | | | | | | | | |
|---|------------------------|------------|----------------|---------------------------|-----------------------------|--|----------|----------|
| CONTROLLED DOCUMENT This specification is a controlled document per AMP Specification 102-21. It is subject to change and Corporate Standards should be contacted for latest revision. | | | | DR B. Beckley 3/23/92 | | AMP AMP Incorporated Harrisburg, PA 17105-3608 | | |
| | | | | CHK R. Buchter 3/25/92 | | | | |
| | | | | APP D. Little 3/25/92 | | NO 108-1101 | REV A | LOC B |
| A | Revised per ECN BG-703 | <i>BxB</i> | <i>4/16/92</i> | PAGE | TITLE | | | |
| LTR | REVISION RECORD | APP | DATE | 1 OF 8 | CONNECTOR, PDS 125 BUS PLUG | | | |

3.3. Ratings

- A. Voltage: 600 volts dc
- B. Current: See Figure 2 for applicable current carrying capability
- C. Temperature: -55 to 105°C
- D. Reliability (see Para 4.5. and 4.6). On the basis of test data it can be said with 95% confidence that 99% of contacts should exhibit a change in contact resistance less than .070 milliohms after 5 years when exposed to class III Mixed Flowing Gas and failure mechanism is corrosion. Terminated to 2 AWG wire and mated with silver plated copper bus bar.

3.4. Performance and Test Description

Product is designed to meet electrical, mechanical and environmental performance requirements specified in Figure 1. All tests are performed at ambient environmental conditions per AMP Specification 109-1 unless otherwise specified.

3.5. Test Requirements and Procedures Summary

| Test Description | Requirement | Procedure |
|--|---|--|
| Examination of product. | Meet requirements of product drawing and AMP Spec 114-2111. | Visual, dimensional and functional per applicable quality inspection plan. |
| ELECTRICAL | | |
| Termination resistance, specified current. | .125 X 4.0 bus bar size; 1 ampere test current; .1 milliohm maximum resistance. | Measure potential drop of mated contacts. Calculate resistance. See Figure 4. AMP Spec 109-25. |
| Temperature rise vs vs current. | 30°C maximum temperature rise at specified current. | Measure temperature rise vs current. See Figure 2. AMP Spec 109-45-1. |
| MECHANICAL | | |
| Vibration, random. | Shall not exceed ΔR 37.5 μ ohm. See Note (a). | Subject mated connectors to 5 G's rms. See Figure 5. AMP Spec 109-21-7. |
| Mating force. | 30 pounds maximum initial per contact. | Measure force necessary to mate connector assembly .550 from point of initial contact using free floating fixtures at rate of .5 inch per minute. Calculate force per contact. AMP Spec 109-42, Condition A. |

Figure 1 (cont)

| | | | | | |
|------------|---|------|----------|-----|-----|
| AMP | AMP Incorporated Harrisburg, PA 17105-3608 | PAGE | NO | REV | LOC |
| | | 2 | 108-1101 | A | B |

| Test Description | Requirement | Procedure |
|----------------------|--|---|
| Unmating force. | 1 pound minimum final per contact. | Measure force necessary to unmate connector assembly at rate of .5 inch per minute. Calculate force per contact. AMP Spec 109-42, Condition A. |
| Durability. | No evidence of damage, cracking or chipping. | Mate and unmate connector assemblies for 100 cycles at a maximum rate of 500 cycles per hour. AMP Spec 109-27. |
| ENVIRONMENTAL | | |
| Mixed flowing gas. | See Note (a). | Subject mated connectors to environmental class III for 20 days. AMP Spec 109-85-3. |
| Temperature life. | See Note (a). | Subject mated connectors to temperature life. AMP Spec 109-43, Test Level 4, Duration I. |

(a) Shall remain mated and show no evidence of damage, cracking or chipping.

Figure 1 (end)

| | | | | |
|--|-----------|----------------|----------|----------|
| AMP AMP Incorporated Harrisburg, PA 17105-3608 | PAGE 3 | NO 108-1101 | REV A | LOC B |
|--|-----------|----------------|----------|----------|

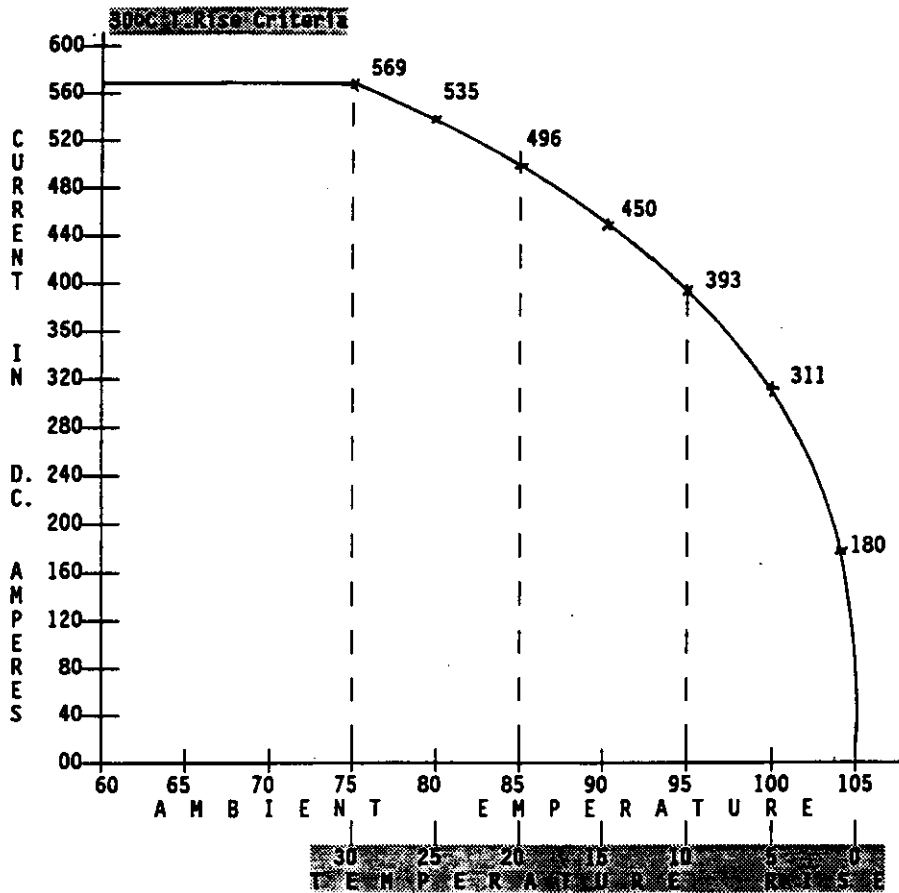

Figure 2A
Current Carrying Capability

| Test Configuration | Multiplication Factor |
|---|-----------------------|
| Contact on 4X12 bar mated with 4X12 bar | 1.00 |
| Contact on 1X12 bar mated with 1X23 bar | 0.40 |
| Contact on AWG #00 mated with 1X12 bar | 0.38 |
| Contact on AWG #2 mated with 1X12 bar | 0.32 |

Figure 2B
Multiplication Factors

| Temperature Rise | 1/8X4X12 mated with 1/8X4X12 Multiplication Factor 1.00 | 1/8X1X12 mated with 1/8X1X23 Multiplication Factor 0.40 | 1/8X1X12 mated with AWG #00 Multiplication Factor 0.38 | 1/8X1X12 mated with AWG #2 Multiplication Factor 0.32 |
|------------------|--|--|---|--|
| 5°C | 311 amperes | 124 amperes | 118 amperes | 99 amperes |
| 10°C | 393 amperes | 157 amperes | 149 amperes | 125 amperes |
| 15°C | 450 amperes | 180 amperes | 171 amperes | 144 amperes |
| 20°C | 496 amperes | 198 amperes | 188 amperes | 158 amperes |
| 25°C | 535 amperes | 214 amperes | 203 amperes | 171 amperes |
| 30°C | 569 amperes | 227 amperes | 216 amperes | 182 amperes |

Figure 2C
Current Rating

3.6. Product Qualification and Requalification Tests

| Test or Examination | Test Group (a) | |
|---|-------------------|-----|
| | 1 | 2 |
| | Test Sequence (b) | |
| Examination of product | 1,10 | 1,4 |
| Termination resistance, specified current | 2,8 | |
| Temperature rise vs current | 3,9 | |
| Vibration | 7 | |
| Mating force | | 2 |
| Unmating force | | 3 |
| Durability | 4 | |
| Mixed flowing gas | 5(c) | |
| Temperature life | 6 | |

(a) See Para 4.1.A.

(b) Numbers indicate sequence in which tests are performed.

(c) Condition samples with 100 cycles durability.

Figure 3

4. QUALITY ASSURANCE PROVISIONS

4.1. Qualification Testing

A. Sample Selection

Contacts shall be prepared in accordance with applicable Instruction Sheets and shall be selected at random from current production. Prepare 30 125F2 connectors along with associated guide plates and measure for each test group a total of 16 assemblies.

4.2. Requalification Testing

If changes significantly affecting form, fit, or function are made to product or manufacturing process, product assurance shall coordinate requalification testing, consisting of all or part of original testing sequence as determined by development/product, quality, and reliability engineering.

4.3. Acceptance

Acceptance is based on verification that product meets requirements of Figure 1. Failures attributed to equipment, test setup, or operator deficiencies shall not disqualify product. When product failure occurs, corrective action shall be taken and samples resubmitted for qualification. Testing to confirm corrective action is required before resubmittal.

4.4. Quality Conformance Inspection

Applicable AMP quality inspection plan will specify acceptable quality sampling level to be used. Dimensional and functional requirements shall be in accordance with applicable product drawing and this specification.

4.5. Reliability Estimates

- A. Estimated reliability is provided relative to acceptance criteria for specific failure mechanisms using environmental test conditions (Heat Age and Mixed Flowing Gas) with known acceleration factors. Heat Age testing and MFG testing have acceleration factors that are generally accepted by industry. Corresponding failure mechanisms are stress relaxation and corrosion. "Estimated reliability" refers to estimated proportion of product whose values of performance parameter (e.g., change in interface resistance) will be on the acceptable side of acceptance criterion. See Para 4.6.
- B. Product reliability relative to a specified acceptance criterion for a particular performance parameter is estimated from environmental test data using one-sided tolerance limit factors (k-factors) for normal distribution. Greatly simplified, the procedure is as follows: Samples of product are subjected to environmental stress testing, and measurements are taken of some performance parameter such as change in interface resistance for pressure connections, or resistance across a solder joint for surface mounted devices, etc. Data is tested for goodness of fit to a normal distribution. If data provides a satisfactory fit to normal distribution, then "k-factor" is computed from $k = (UL - X)/S$, where:

UL Denotes the specified allowable upper limit, or acceptance criterion, for performance parameter.

Note: Measurements greater than UL indicate product failure).

X Denotes average of sample measurements.

S Denotes standard deviation of sample measurements (calculated using a denominator of $n-1$, where n denotes sample size)

Calculated value of k is then compared with table of factors for one-sided tolerance limits for a normal distribution to determine product reliability and associated "confidence" that may be claimed, based on test data.

- C. Acceptance criterion used is maximum change in contact resistance permitted in dry circuit resistance test as determined from contact physics (constriction resistance and super-temperature for high current contacts at rated current). Variable data of change in termination resistance is considered acceptable for making estimates of product reliability if a normal probability plot and appropriate statistical analysis indicate agreement of data with a normal distribution.

4.6. Reliability Tests

Following tests shall be performed to determine estimates of reliability:

A. Temperature Life

10 contacts shall be tested at 135°C for period of 7 days. Measurements shall be taken at 7 days according to requirements of Test Specification 109-43.

B. Mixed Flowing Gas

10 contacts shall be tested according to class III of Test Specification 109-85. Separable connections shall be mated and unmated for 10 cycles before submission to Mixed Flowing Gas test.

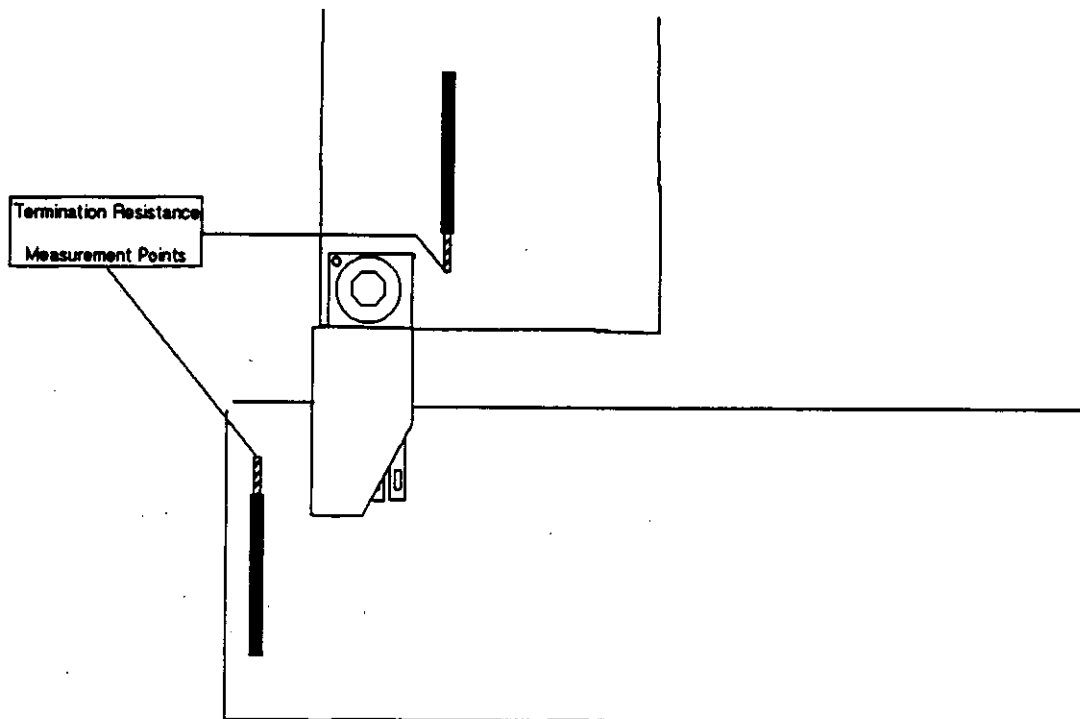

Figure 4
Termination Resistance Measurement Points

AMP

AMP Incorporated
Harrisburg, PA 17105-3608

PAGE NO

7

108-1101

REV

A

LOC

B

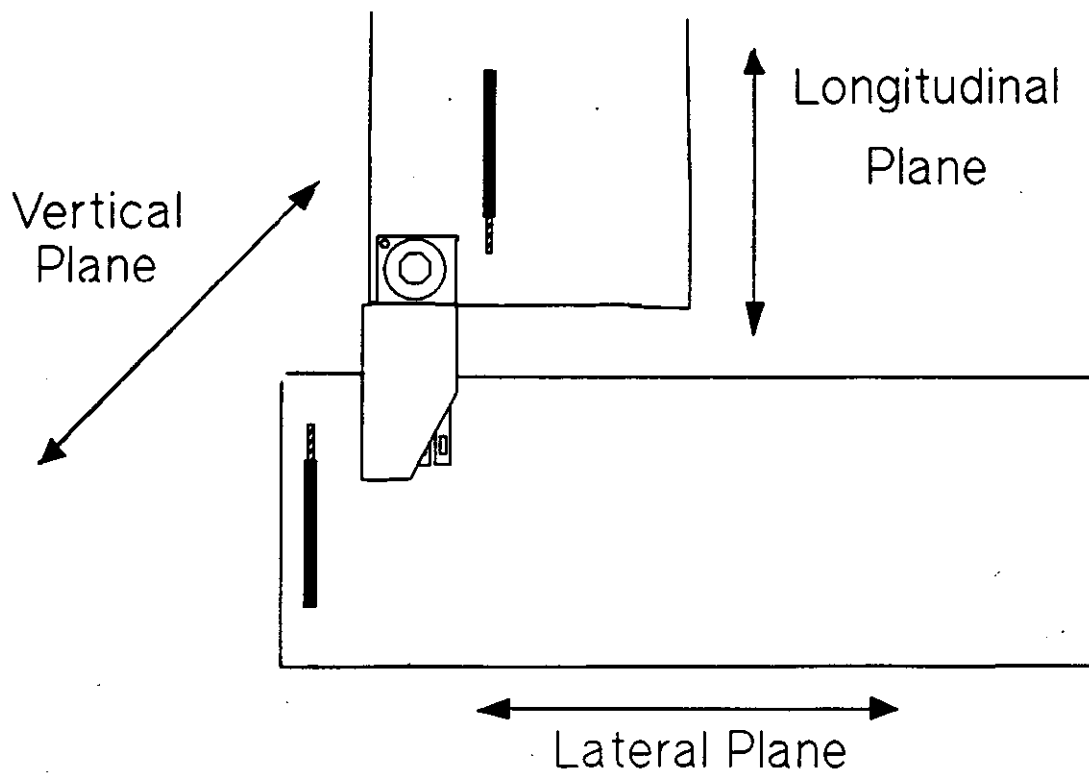

Figure 5
Vibration Planes

单击下面可查看定价，库存，交付和生命周期等信息

[>>TE Connectivity\(泰科\)](#)