AMPSEAL* Connectors

1. SCOPE

1.1. Content

This specification covers performance, tests and quality requirements for AMPSEAL* connectors.

1.2. Qualification

When tests are performed on subject product line, procedures specified in Figure 1 shall be used. All inspections shall be performed using the applicable inspection plan and product drawing.

1.3. Successful qualification testing on the subject product line was completed on 24Sep93. The Qualification Test Report number for this testing is 501-231. This documentation is on file at and available from Engineering Practices and Standards (EPS).

2. APPLICABLE DOCUMENTS

The following documents form a part of this specification to the extent specified herein. Unless otherwise specified, the latest edition of the document applies. In the event of conflict between the requirements of this specification and the product drawing, the product drawing shall take precedence. In the event of conflict between the requirements of this specification and referenced documents, this specification shall take precedence.

2.1. TE Connectivity (TE) Documents

- 109-1: Test Specification (General Requirements for Test Specifications)
- 109-151: Test Specification (Current Rating Verification)
- 109 Series: Test Specifications as indicated in Figure 1
- 114-16016: Application Specification (AMPSEAL* Automotive Plug Connector and Header Assembly)
- 501-231: Qualification Test Report (AMPSEAL* Connectors)

2.2. Reference Documents

- 502-1054: Engineering Report (Evaluation Testing of AMPSEAL* Pin & Socket Contact System)
- 502-1264: Engineering Report (Evaluation Testing of AMPSEAL* Plug Assemblies)
- 502-1266: Engineering Report (Dust and High Pressure Spray Validation Testing of AMPSEAL* Plug Assemblies)
- 502-1267: Engineering Report (Dust and Immersion Validation Testing of AMPSEAL* Plug Assemblies)

3. REQUIREMENTS

3.1. Design and Construction

Product shall be of the design, construction and physical dimensions specified on the applicable product drawing.

3.2. Materials

Materials used in the construction of this product shall be as specified on the applicable product drawing.

3.3. Ratings

- Voltage: 250 volts AC
- Current: See Figure 2 for applicable current carrying capability
- Temperature: -40 to 105°C for tin plated product; -40 to 125°C for gold plated product

3.4. Performance and Test Description

Product is designed to meet the electrical, mechanical and environmental performance requirements specified in Figure 1. Unless otherwise specified, all tests shall be performed at ambient environmental conditions per Test Specification 109-1.

3.5. Test Requirements and Procedures Summary

Test Description	Requirement	Procedure												
Examination of product.	Meets requirements of product drawing and Application Specification 114-16016.	Visual, dimensional and functional per applicable quality inspection plan.												
ELECTRICAL														
Termination resistance, dry circuit.	10 milliohms maximum.	TE Spec 109-6-7. Subject mated specimens to 20 millivolt maximum open circuit at 50 milliamperes maximum. See Figure 4.												
Termination resistance, specified current.	<table border="1" style="display: inline-table; vertical-align: middle;"> <thead> <tr> <th>Wire Size (AWG)</th> <th>Test Current (amperes)</th> <th>Resistance (milliohms maximum)</th> </tr> </thead> <tbody> <tr> <td>16</td> <td>6.0</td> <td>10</td> </tr> <tr> <td>18</td> <td>4.5</td> <td>10</td> </tr> <tr> <td>20</td> <td>3.0</td> <td>10</td> </tr> </tbody> </table>	Wire Size (AWG)	Test Current (amperes)	Resistance (milliohms maximum)	16	6.0	10	18	4.5	10	20	3.0	10	TE Spec 109-25. Measure potential drop of mated contacts assembled in housing. Calculate resistance. See Figure 4.
Wire Size (AWG)	Test Current (amperes)	Resistance (milliohms maximum)												
16	6.0	10												
18	4.5	10												
20	3.0	10												
Insulation resistance.	100 megohms minimum.	TE Spec 109-28-4. Test between adjacent contacts of mated specimens.												
Dielectric withstanding voltage.	One minute hold with no breakdown or flashover.	TE Spec 109-29-1. 1000 volts AC at sea level. Test between adjacent contacts of mated specimens.												
Temperature rise vs current.	40°C maximum temperature rise at specified current.	TE Spec 109-45-1. Measure temperature rise vs current. See Figures 2 and 4.												
Current cycling.	See Note.	TE Spec 109-51, Condition B, Test Method 4. Subject mated specimens to 500 cycles at 125% of rated current for 45 minutes ON and 15 minutes OFF.												

Figure 1 (continued)

Test Description	Requirement	Procedure								
MECHANICAL										
Solderability.	Solderable area shall have minimum of 95% solder coverage.	TE Spec 109-11-2. Subject contacts to solderability.								
Crimp tensile.	<table border="1" style="margin-left: auto; margin-right: auto;"> <tr> <td>Wire Size (AWG)</td> <td>Crimp Tensile (N minimum)</td> </tr> <tr> <td>20</td> <td>80</td> </tr> <tr> <td>18</td> <td>90</td> </tr> <tr> <td>16</td> <td>150</td> </tr> </table>	Wire Size (AWG)	Crimp Tensile (N minimum)	20	80	18	90	16	150	TE Spec 109-16. Determine crimp tensile at maximum rate of 25.4 mm per minute.
Wire Size (AWG)	Crimp Tensile (N minimum)									
20	80									
18	90									
16	150									
Sinusoidal vibration.	No discontinuities of 1 microsecond or longer duration. See Note.	TE Spec 109-21-2. Subject mated specimens to 10 Gs between 10 to 500 Hz with 1 octave minimum sweep rate. Sixteen hours in each of 3 mutually perpendicular planes. See Figure 5.								
Random vibration.	See Note.	TE Spec 109-21-7, Condition G, except 10 to 500 Hz frequency range. Subject mated specimens to 10 Gs for 8 hours each plane. See Figure 5.								
Physical shock.	No discontinuities of 1 microsecond or longer duration. See Note.	TE Spec 109-26-1. Subject mated specimens to 50 Gs half-sine shock pulses of 11 milliseconds duration. Three shocks in each direction applied along 3 mutually perpendicular planes, 18 total shocks. See Figure 5.								
Durability.	See Note.	TE Spec 109-27. Mate and unmate specimens for 10 cycles at maximum rate of 600 cycles per hour.								
Contact retention.	Contacts shall not dislodge.	TE Spec 109-30. Apply an axial load of 115 N to contacts in the axial direction with Wedge Lock in locked position.								
Contact insertion.	10 N maximum per contact.	TE Spec 109-41. Measure force necessary to insert contacts into the housing.								
Mating force.	180 N maximum.	TE Spec 109-42, Condition A. Measure force necessary to mate specimens with locking latches using free floating fixtures at a maximum rate of 12.7 mm per minute.								

Figure 1 (continued)

Test Description	Requirement	Procedure
Unmating force.	100 N maximum.	TE Spec 109-42, Condition A. Measure force necessary to unmate specimens with locking latches removed or released at a maximum rate of 12.7 mm per minute.
Housing lock strength.	160 N minimum.	TE Spec 109-50. Determine strength of housing locking mechanism at a maximum rate of 13 mm per minute.
Immersion.	Leakage current not to exceed 50 micro-amperes at 48 volts DC.	TE Spec 109-74-5. Immerse specimens to a depth of 100 mm in 5% salt water at a temperature of $23 \pm 5^\circ\text{C}$ for 1 hour. Check between adjacent circuits and each surface to reference electrode.
Polarizing and keying feature strength.	Shall withstand 175 N minimum.	TE spec 109-1018. Attempt to mate specimens against polarizing or keying feature.
ENVIRONMENTAL		
Temperature life.	See Note.	TE Spec 109-43. Subject mated specimens to temperature life at 155°C for 100 hours for gold plated product, and 100°C for 500 hours for tin plated product.
Mixed flowing gas.	See Note.	TE Spec 109-85-2. Subject mated specimens to Environmental Class II for 20 days.
Humidity/temperature cycling.	See Note.	Subject mated specimens to 10 humidity/temperature cycles. See Figure 6.

NOTE

Shall meet visual requirements, show no physical damage and shall meet requirements of additional tests as specified in Test Sequence in Figure 3.

Figure 1 (end)

AMPSEAL* CONNECTOR SYSTEM
 Maximum Temperature Rise, P_{.95}, 0.99 Reliability
 Single Circuit, 16 AWG

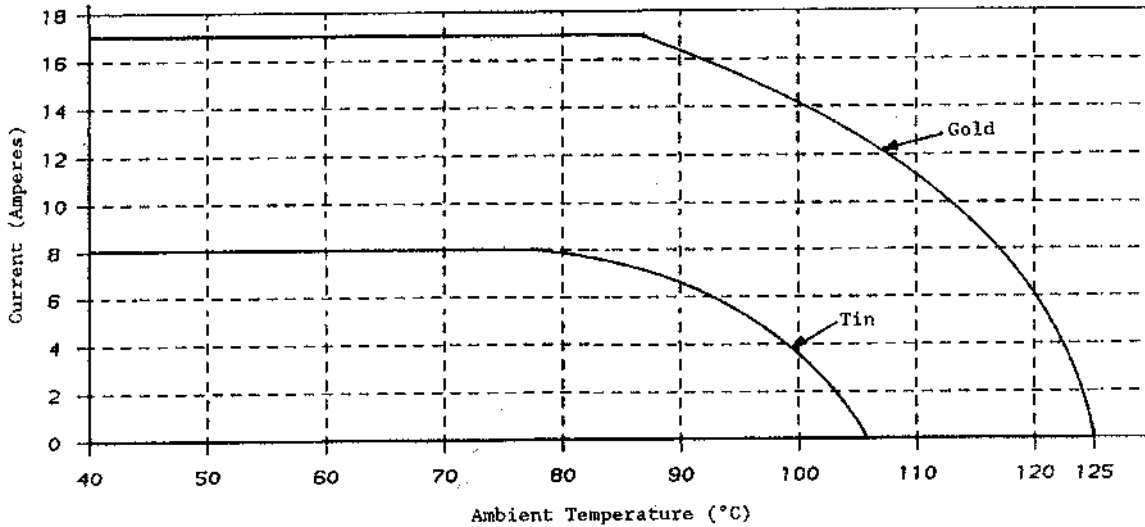

Figure 2A
 Current Carrying Capacity

	16 AWG	18 AWG	20 AWG
LOADING DENSITY			
SINGLE CIRCUIT	1.0	.89	.80
X X 2 CIRC LOADING	.99	.88	.80
X X X X 4 CIRC LOADING	.92	.82	.74
X . X . . X . X 4 CIRC LOADING	.90	.80	.72
X . X . X . X . X . X . X . X . X . X . X . X 12 CIRC LOADING	.63	.56	.50
X 23 CIRC LOADING	.49	.43	.39

NOTE To determine the acceptable current carrying capacity for the percentage connector loading and wire gage indicated, use the Multiplication Factor (F) from the above chart and multiply it times the Base Rated Current for a single circuit at maximum ambient operating temperature as shown in Figure 2A.

Figure 2B
 Current Rating

3.6. Product Qualification and Requalification Test Sequence

Test or Examination	Test Group (a)						
	1	2	3	4	5	6	7
	Test Sequence (b)						
Examination of product	1	1,11	1,7	1,5	1	1,3	1,12
Termination resistance, dry circuit	3,7	2,7,10					
Termination resistance, specified current				2,4			
Insulation resistance			2,5				3,6,10
Dielectric withstanding voltage			3,6				2,5,9
Temperature rise vs current		3,9					
Current cycling				3			
Solderability						2	
Crimp tensile	10				4		
Sinusoidal vibration	5						
Random vibration		8(c)					
Physical shock	6						
Durability	4	4					
Contact retention					3		
Contact insertion					2		
Mating force	2						
Unmating force	8						
Housing lock strength	9						
Immersion							4,8
Polarizing and keying feature strength							11
Temperature life		6					7
Mixed flowing gas		5					
Humidity/temperature cycling			4				

- NOTE** (a) See paragraph 4.1.A.
 (b) Numbers indicate sequence in which tests are performed.
 (c) Discontinuities shall not be measured. Energize at 18 °C level for 100% loadings per Test Specification 109-151.

Figure 3

4. QUALITY ASSURANCE PROVISIONS

4.1. Qualification Testing

A. Sample Selection

Specimens shall be prepared in accordance with applicable Instruction Sheets and shall be selected at random from current production. Test groups 1 and 4 shall consist of 2 specimens. Test group 2 shall consist of 8 specimens with circuits 1, 8, 16 and 23 identified. Test group 3 shall consist of 6 specimens. Test group 5 shall consist of 1 specimen with 6 leads loaded with the maximum AWG wire size and 6 leads with the minimum AWG wire size. Test group 6 shall consist of 1 specimen. Test group 7 shall consist of 2 specimens loaded with the maximum AWG wire size and 2 specimens loaded with the minimum AWG wire size.

B. Test Sequence

Qualification inspection shall be verified by testing samples as specified in Figure 3.

4.2. Requalification Testing

If changes significantly affecting form, fit or function are made to the product or manufacturing process, product assurance shall coordinate requalification testing, consisting of all or part of the original testing sequence as determined by development/product, quality and reliability engineering.

4.3. Acceptance

Acceptance is based on verification that the product meets the requirements of Figure 1. Failures attributed to equipment, test setup or operator deficiencies shall not disqualify the product. When product failure occurs, corrective action shall be taken and specimens resubmitted for qualification. Testing to confirm corrective action is required before resubmittal.

4.4. Quality Conformance Inspection

The applicable quality inspection plan shall specify the sampling acceptable quality level to be used. Dimensional and functional requirements shall be in accordance with the applicable product drawing and this specification.

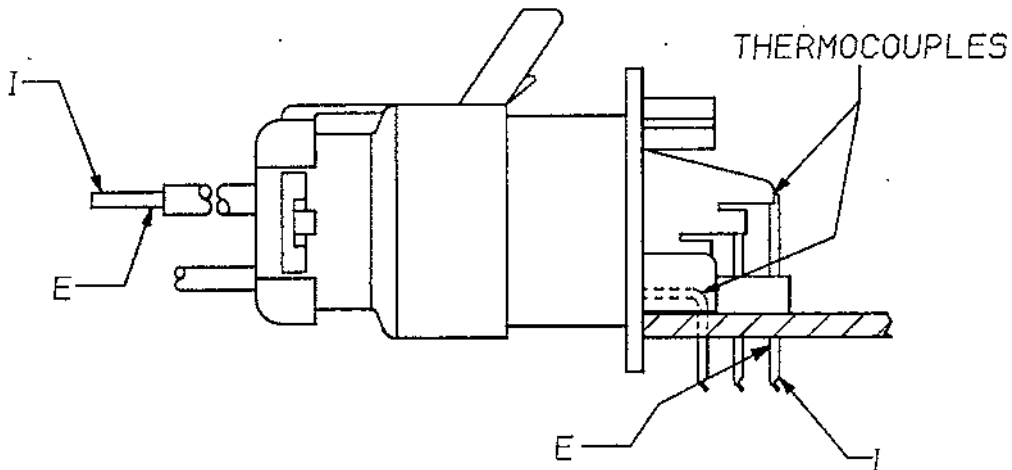
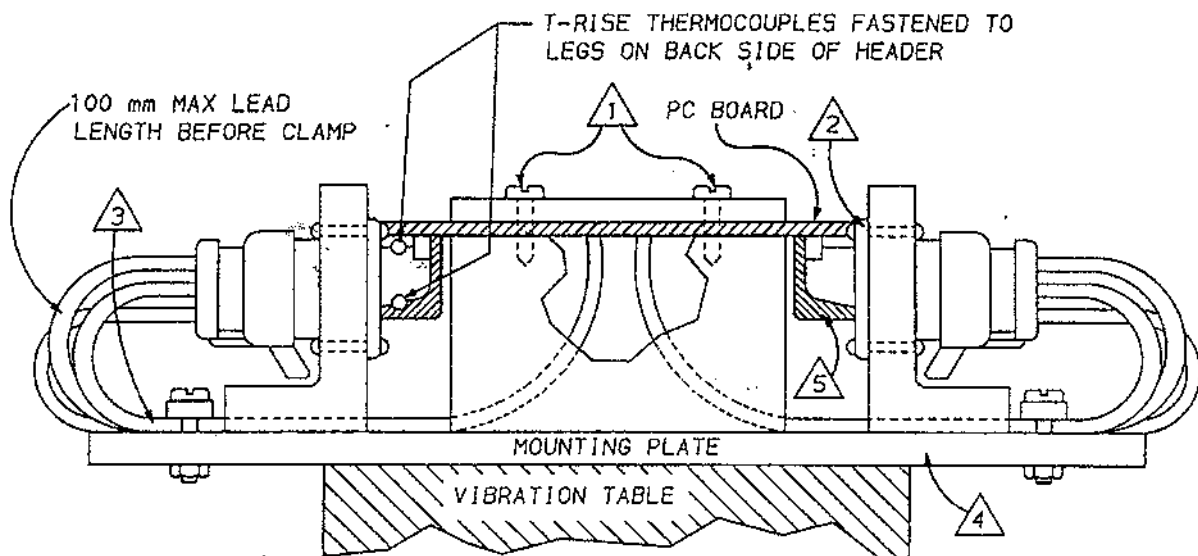
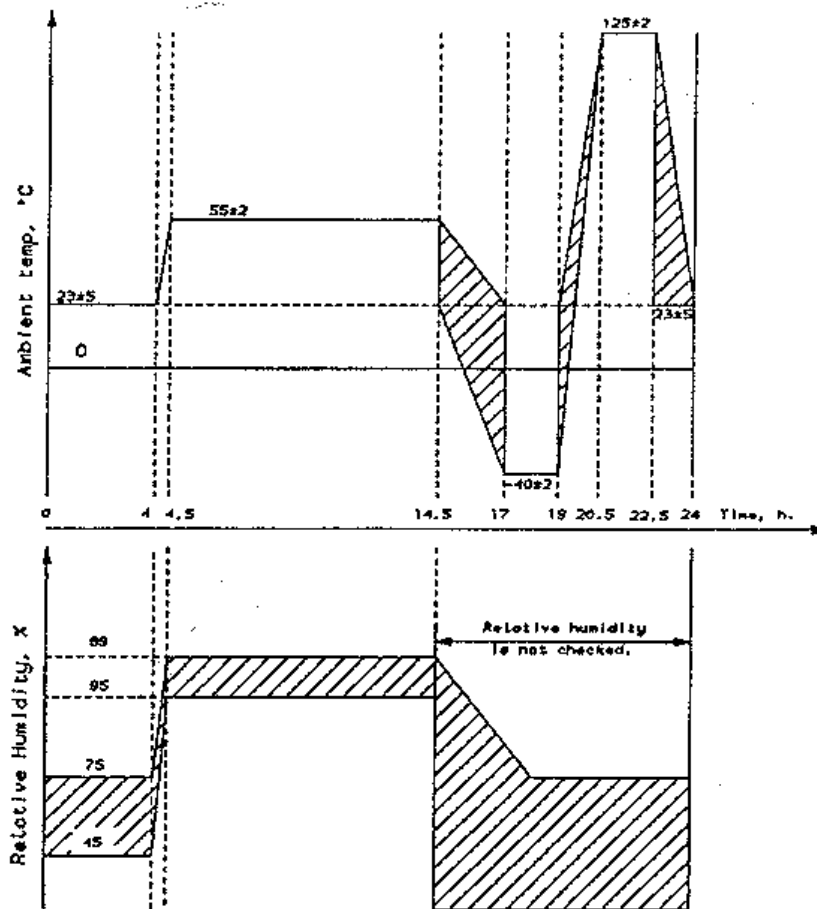

Figure 4
Resistance and Temperature Measurement Points



- NOTE**
1. PCB fastened to mounting plate.
 2. Header flanged fastened to mounting plate.
 3. Lead wires fastened to mounting plate.
 4. All components fastened so that the mounting plate can be removed from the vibration table without disturbing the test components.
 5. Back side of the headers potted

Figure 5
Vibration and Physical Shock

NOTE

1. The humidity/temperature cycling test shall be carried out with the housing having the full complement of contacts. The specimen shall be tested with the cable assembled of minimum and maximum cross-sectional area that the contact system allows.
2. Specimens shall be subjected to 10, 24 hour cycles of the following:
 - a. Hold at 23 ± 5 °C for 4 hours at 45 to 75% Relative Humidity (RH).
 - b. Raise chamber temperature to 55 ± 2 °C at 95 to 99 % RH within 0.5 hour.
 - c. Hold at 55 ± 2 °C for 10 hours at 95 to 99% RH.
 - d. Lower chamber temperature to -40 ± 2 °C within 2.5 hours.
 - e. Hold at -40 ± 2 °C for 2 hours.
 - f. Raise chamber temperature to 125 ± 2 °C within 1.5 hours.
 - g. Hold at 125 ± 2 °C for 2 hours.
 - h. Recover to 23 ± 5 °C within 1.5 hours.
3. RH is controlled during periods d, e, f, g and h.
4. At the end of a cycle, the test may be interrupted. During the interruption, specimens shall remain at ambient conditions defined in paragraph 2a. Interruption time shall be noted in the test report.

Figure 6
Humidity/Temperature Cycling

单击下面可查看定价，库存，交付和生命周期等信息

[>>TE Connectivity\(泰科\)](#)