

CELLO CONNECTOR (DIN41612 CONNECTOR)

1. SCOPE

1.1 Contents

This specification covers performance, tests and quality requirements for **CELLO CONNECTOR (DIN 41612 CONNECTOR)**.

1.2 Qualification

When required tests are performed on the subject products, procedures specified in TE 109 series specifications shall be used. All inspections shall be performed using the applicable inspection plan and product drawing.

2. APPLICABLE DOCUMENTS

The following documents form a part of this specification to the extent specified herein. Unless otherwise specified, the latest edition of the document applies. In the event of conflict between the requirements of this specification and the product drawing, the product drawing shall take precedence. In the event of conflict between the requirements of this specification and the referenced documents, this specification shall take precedence.

2.1 TE Connectivity Document:

- A. 109-1: General Requirements for Test Specifications
- B. 109 series: Test Specification as indicated in figure 2 (Comply with MIL-STD-202)
- C. Corporate Bulletin 401-76:
Cross-reference between TE test specifications and Military or Commercial Documents.
- D. 501-137009: Test Report of CELLO connector

2.2 International Standards

- DIN41612/IEC60603: Connectors for frequencies below 3 MHz for use with printed board.
- EIA-364: Electrical Connector/Socket Test Procedures Including Environment Classification

3. REQUIREMENTS

3.1 Design and Construction

Product shall be of the design, construction and physical dimensions specified on the applicable product drawings.

3.2 Materials

- A. Housing: Thermoplastic or high temp. Thermoplastic, UL94V-0 rated, Black or other color specified.
- B. Contact: Copper Alloy,
- C. Finish Plating:
 - C.a. Level 3: 0.076um MIN gold on mating area or covers the whole pin/contact
Level 2: 0.25um MIN gold on mating area or covers the whole pin/contact
Level 1: 0.76um MIN gold on mating area or covers the whole pin/contact
 - C.b. 3.81~6.35um, or specified thickness, tin plating on soldering area or covers whole pin/contact
***Note: Lead-free tin plating is mandatory in accordance with RoHS2.0,
Or other specified tin standard in accordance with customized requirement.**
 - C.c. 1.27um nickel under-plating covers whole pin/contact

3.3 Ratings

- A. The permissible operating voltages depend on the application and on the applicable or specified requirements.
Therefore the clearance and creepage distance are given as operating characteristics.
- B. Current Rating: PER DIN41612
Conditions: IEC 512-3, Test 5b

Standard atmospheric conditions
All contacts

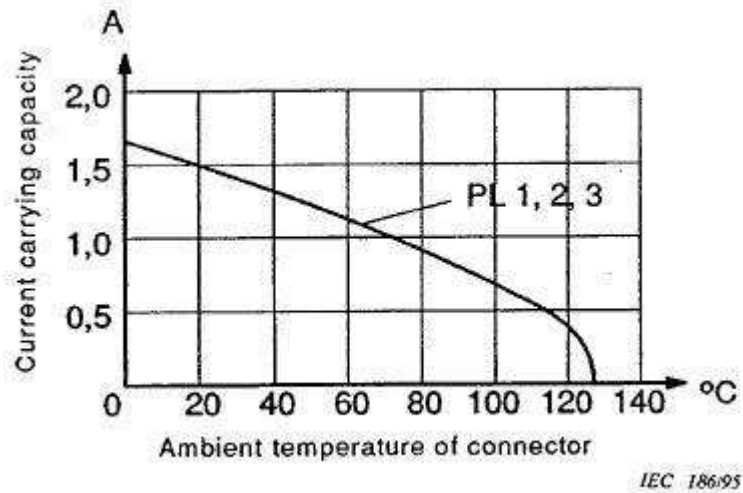

Fig.1 Styles B, C, M, Q and R

C. Initial insulation resistance
All performance levels: $10^6 M\Omega$ min

3.4 Performance Requirements and Test Descriptions

Product is designed to meet the electrical, mechanical and environmental performance requirements specified in Figure 3. Unless otherwise specified, all tests shall be performed at ambient environmental conditions per AMP Specification 109-1.

3.5 Test Requirements and Procedures Summary

Test Description	Procedures	Performance level	Requirements	
			B Q	C R
Examination of product	Unmated connectors Visual inspection No physical damage. IEC 60512, Test 1a	1 2 3	No defect would impair normal operation	
	Unmated connectors Inspection per product drawing. IEC 60512, Test 1b	1 2 3	Meets requirements of product drawing.	

ELECTRICAL

Low Level Contact Resistance(LLCR)	Connection points according to Fig.6 IEC 60512-2-1, Test 2a	1 2 3	20mΩ maximum
Insulation Resistance	100V±15V DC Mated connectors according Fig.7 IEC 60512-3-1, Test 3a	1	$10^6 M\Omega$ min
		2	
Insulation Resistance(after environment test)	100V±15V DC Mated connectors according Fig.7 IEC 60512-3-1, Test 3a	1 2	$10^4 M\Omega$
		3	$10^3 M\Omega$
Voltage proof (withstanding voltage)	All contact connected together to shield according to Fig.7 IEC 60512-4-1, Test 4a	1 2 3	1000V (r.m.s)
Electrical load and temperature	70°C	1	1A at 70°C
		2	

	Wire gauge for style: B.C.Q.R=0.12mm ² IEC 60512 test 9b		
		3	Not applicable

MECHANICAL

Vibration	Arrangement according to FIG. 8 Endurance by sweeping 10Hz-2000Hz 1.5mm or 20g Sweep cycles:10 Duration:7.5h	1	Duration of disturbance 1µs max.			
		2	Not applicable			
		3				
	10Hz-500Hz 0.35mm or 5g Sweep cycle:10 Duration:6h IEC60512, Test 6d	1	Not applicable			
		2	Duration of disturbance 1µs max.			
		3	Not applicable			
Shock	Arrangement according to Fig.8 Half sine shock acceleration 490m/s ² (50g) Duration of impact:11ms IEC60512, Test 6c	1	No discontinuities of 1µs max.			
		2	Not applicable			
		3				
Acceleration	Arrangement according to Fig.8 Acceleration:980 m/s ² Duration:5 min per axis IEC60512, Test 6a	1	No discontinuities of 1µs max.			
		2	Not applicable			
		3				
Durability	Max speed of operations= 10 mm/s Rest:30s, unmated IEC 60512, Test 9a	1	250 operations			
		2	200 operations			
		3	25 operations			
Mating and Un-mating Force	Max. speed= 10 mm/s IEC 60512-13-2, Test 13b	1	Insertion and withdrawal force Fmax			
		2	64PIN S: 60N	96PIN S	64PIN S	32PINS
		3		90N	60N	30N
Solderability	Solder bath method Test Ta,method 1 Free board connector" Immersion depth 2.6mm min. Fixed board connector: Board thickness up to 1.6mm Immersion depth 2.00mm min Board thickness up to 2.4mm Immersion depth 3.5mm min IEC60512 test 12a	1	The inspected area of each lead must have 95% solder coverage MIN.			
		2				
		3				
Contact retention in insert	Free Connectors 6 contact/specimen IEC60512 TEST 15a	1	10N			
		2				
		3	Not applicable			

ENVIRONMENTAL

Rapid change in temperature	Subject specimens to 5 cycles between -55 and 125°C with 30 minute at temperature extremes. IEC 60512 test 11d	1 2	There shall be no defect that would impair normal operation See note.
		3	Not applicable
Damp heat, cycle, first cycle	PL1: 55°C PL2: 40°C	1 2	Visual examination There shall be no defect that would impair normal operation
		3	Not applicable
Cold	-55°C Duration: 2h Recovery time: 2h	1 2 3	There shall be no defect that would impair normal operation
Damp heat, remaining cycle	Condition according to Damp heat cycle, first cycle PL1:5 cycles PL2:1 cycle	1 2	Insulation resistance at high temperature: 10 ⁴ MΩmin
		3	Not applicable
Dry heat	Temperature:125°C Test voltage 100V±15V DC Mated connectors Method B IEC60512,test 11i	1 2	Insulation resistance at high temperature: 10 ⁵ MΩmin
		3	Insulation resistance at high temperature: 10 ⁴ MΩmin
Damp heat, steady state	Polarization-voltage:60V D.C IEC60512 test 11c	1	56days
		2	21days
		3	Not applicable
Industrial atmosphere(half mated; half unmated)	Tests According to annex A	1	10 days
		2	4 days
		3	Not applicable
Mould growth	IEC60512 test 11e	1	There shall be no defect that would impair normal operation
		2 3	Not applicable
		3	Not applicable
Combustibility	Test flame No.1 Arrangement of specimen According to Fig.10 Duration of application:10s	1	Post burning time 10s max
		2 3	Not applicable
		3	Not applicable

Fig.2 (End)

* Notes

A) Product must be without rust, corrosion transformation, crack and discoloration.

B) Product must meet visual requirements, shows no physical damage, and must meet requirements of additional tests as specified in the Product Qualification and Requalification.

3.6 Product Qualification Test Sequence

Test or Examination	Test Group						
	P	AP	BP	CP	DP	EP	FP
	Test Sequence						
Visual Examination	1	17	7	5	5	4	1,3
Contact Resistance	2	14	3	3	3		
Insulation Resistance	3	7	5				
Insulation Resistance(after environment testing)		13		2			
Dielectric Strength	4	2,8,15	6	4	4		
Mating & Unmating force		1,16					
Solderability							2
Vibration		3					
Shock		4					
Acceleration		5					
Rapid temperature Change		6					
Dry heat		9					
Damp heat, cycle, first cycle		10					
Cold		11					
Damp heat. Cycle, remaining cycles		12					
Durability			1,4		1		
Industrial Atmosphere			2				
Damp heat, steady state				1			
Electric load at High Temperature					2		
Contact retention in insert						1	
Mould Growth						2	
Flammability						3	

Fig.3 Test sequence

*** Notes:**

1. Numbers indicate the sequence in which the tests are performed.
2. When the initial tests have been completed, all the specimens are divided up according to the test group. Before testing commences, the connectors must have been stored for at least 24 h unmated under normal climatic conditions for testing as per IEC 68-1.

4. Quality Assurance Provisions:

4.1 Test Conditions :

Unless otherwise specified, all the tests shall be performed in the combination of the following test conditions.

Temperature :	15~35°C
Relative Humidity :	45~75%
Atmospheric Pressure :	86.6~106.6Kpa

Fig. 4 Test Conditions

4.2 Tests

4.2.1 Test Specimens

The test specimens to be employed for the tests shall be conforming to the requirements specified in the applicable product drawings.

For a complete test sequence the following numbers of specimens are necessary.

Test specimens			
Performance level	1	2	3
	Number of specimens		
Initial tests(P)	30	24	12
Group AP	6	4	4
Group BP	8	4	4
Group CP	4	4	-
Group DP	4	4	-
Group EP	4	4	-

Fig. 5

4.2.2 Test Sequence

Qualification inspection shall be verified by testing specimens as specified in fig.3.

4.2.3 Typical Terminal Resistance Measurement points

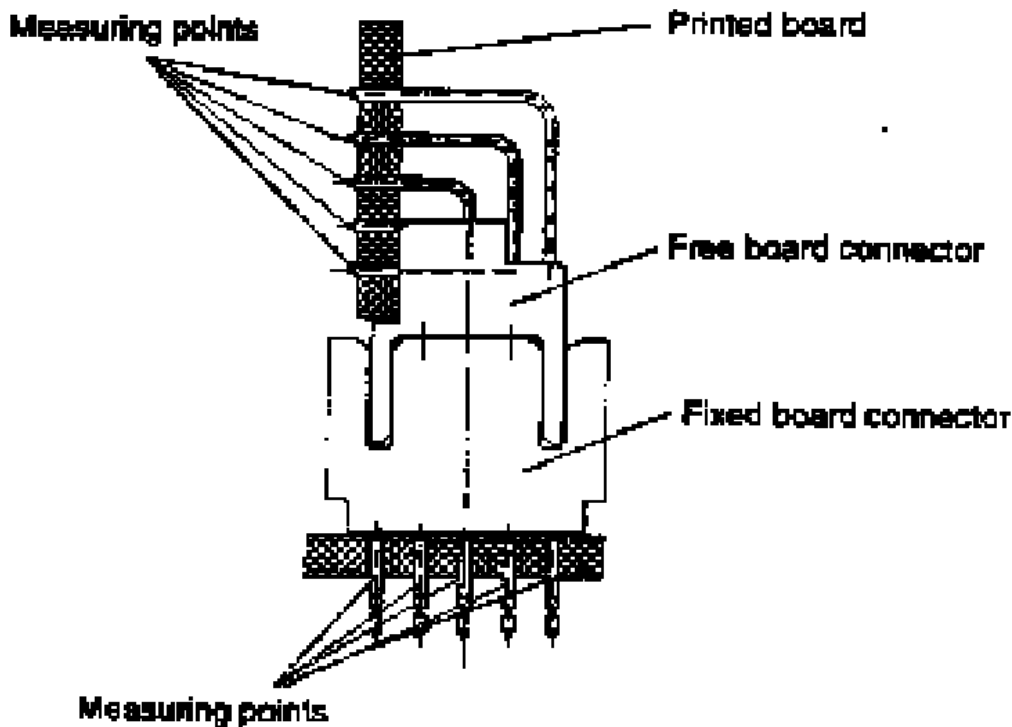
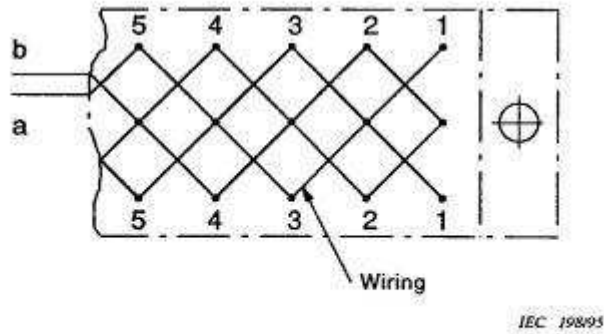

Fig. 6 Typical Terminal Resistance Measurement points

* **Notes:** When the termination resistance test is performed, plating of the post contacts shall be corresponding to that of receptacle contact to be used for testing.

4.2.4 Wiring arrangement for insulation resistance, voltage proof and polarization voltage during damp heat test.



Measuring: 1) between a and b
2) between a and b and test panel

Fig. 7 wiring arrangement for insulation resistance, Voltage proof and polarization voltage during damp heat test

4.2.5 Arrangement for vibration, shock and acceleration test

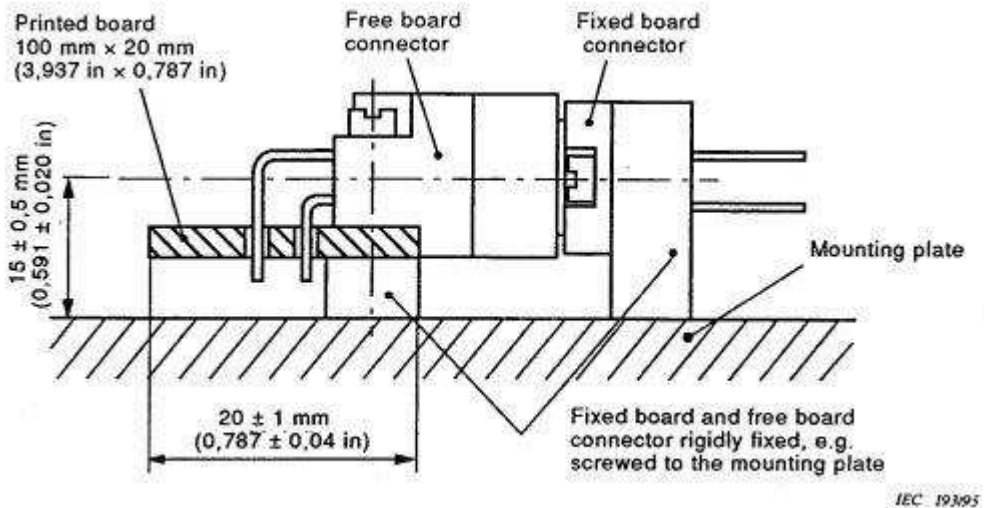

Fig.8 Arrange for connectors without cable/wires

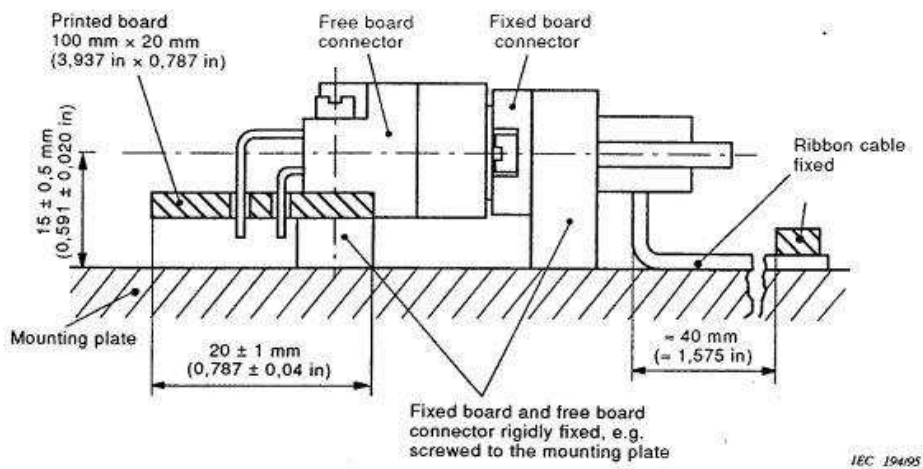

Fig. 9 Arrangement for connectors with ribbon cable (insulation displacement)

4.2.6 Arrangement for flammability test

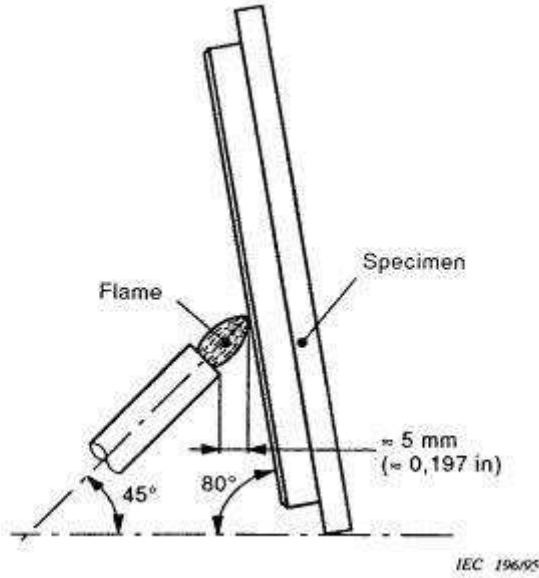

Fig. 10 Arrangement for flammability test

4.2.7 Arrangement for static load, axial

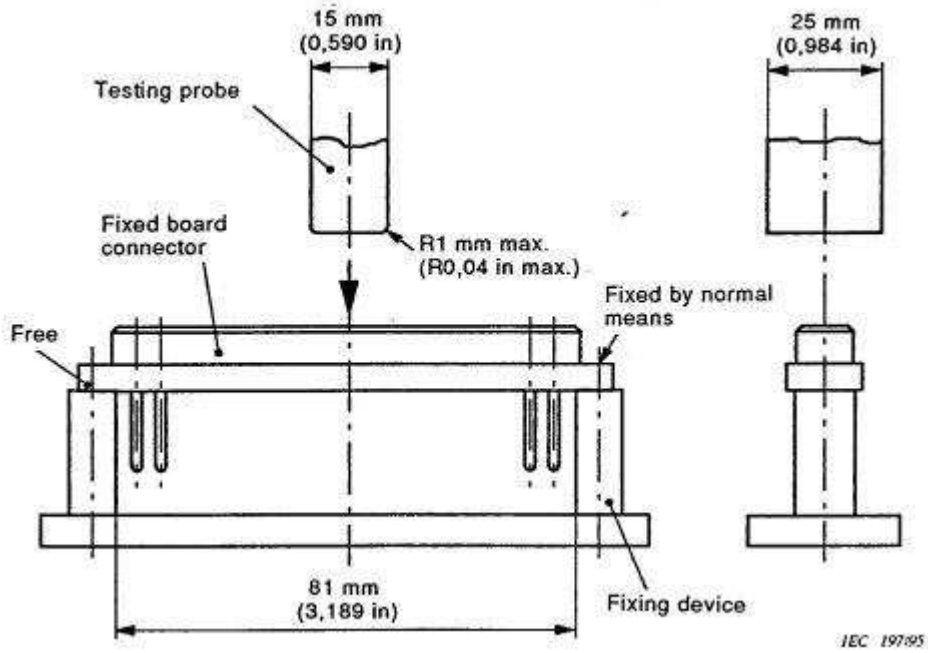

Fig.11 Arrangement for static load, axial

Annex A
(Normative)
TEST corrosion, industrial atmosphere

A.1 General

This annex is intended to define a corrosion test procedure using two polluting gases for assessing the performance of the connector modules described in this specification.

A.2 Test equipment

Attentions shall be paid to the design of equipment and the choice of the materials of construction, in order

- That the conditions are uniform (better than ± 1 °C for temperature and $\pm 3\%$ for relative humidity) through the working space
- That they are repeatable and reproducible
- To ensure no condensation in the test chamber

The test equipment shall be capable of injecting the gases up to the concentrations as described in A.3.1

WARNING: Attention is drawn to the risk deriving from the specified use of SO₂ and H₂S gases.

A.3 Test procedure

A.3.1 Test conditions

- METHOD A

Applicable for contact plating of gold and gold alloys only

Polluting gas: SO₂(10 ± 2) 10^{-6} (vol/vol)

Temperature: (25 ± 1)°C

Relative humidity: (75 ± 3) %

Duration: 4, 10 or 21 days

- METHOD B

Applicable for contact plating of silver and silver alloys only

Polluting gas: H₂S(1 ± 0.3) 10^{-6} (vol/vol)

Temperature: (25 ± 1)°C

Relative humidity: (75 ± 3) %

Duration: 4, 10 or 21 days

A.3.2 Conditioning

The specimen shall be placed in the working space.

The conditions of the specimens and the test chamber shall be such that condensation on the specimen shall not occur when they are introduced in the test chamber.

The temperature inside the chamber shall be adjusted to the prescribed value.

After at least 1 h at a constant temperature, humidity shall be introduced and adjusted to the prescribed value.

These conditions shall be maintained for at least 1 h.

The polluting gases shall then be introduced into the airstream and the concentrations adjusted to the values specified in the test method. During this adjustment any over-shooting of the gas concentration shall be avoided.

The test duration shall be measured from the start of injection of the polluting gases.

At the conclusion on of the test, the injection of polluting gases shall be stopped and the specimens allowed to remain in the humid atmosphere for 2 h.

A.3.3 Recovery

The specimens shall be removed from the chamber and stored under standard recovery conditions as specified in IEC 68-1 for not less than 1 h and not more than 24 h before final measurement are made.

单击下面可查看定价，库存，交付和生命周期等信息

[>>TE Connectivity\(泰科\)](#)