Connector, Z-PACK*, 8 Row, 2mm HM

1. SCOPE

1.1. Content

This specification covers performance, tests and quality requirements for the Z-PACK* 8 row, 2mm HM connector system. These connectors are two-piece devices to interconnect 2 printed circuit boards. Receptacle and pin connectors are through hole devices with ACTION PIN* contacts. Connectors are in 8 row configurations and can be upgraded to 10 row configuration.

1.2. Qualification

When tests are performed on subject product line, procedures specified in IEC 512 (see Figure 8) shall be used. All inspections shall be performed using applicable inspection plan and product drawing.

2. APPLICABLE DOCUMENTS

The following documents form a part of this specification to the extent specified herein. Unless otherwise specified, latest edition of the document applies. In the event of conflict between requirements of this specification and product drawing, product drawing shall take precedence. In the event of conflict between requirements of this specification and referenced documents, this specification shall take precedence.

2.1. TE Connectivity (TE) Document

501-326: Qualification Test Report

2.2. Commercial Standards

IEC 512: Test Specification

3. REQUIREMENTS

3.1. Design and Construction

Product shall be of design, construction and physical dimensions specified on applicable product drawing.

3.2. Materials

- Coding devices: Polyamide 35% GF, UL94HB
- Contact: Phosphor bronze, gold over nickel plating in contact area
- Housing: Thermoplastic polyester, 20% GF, UL94V-0

3.3. Ratings

- Voltage: 750 vrms contact to contact
- Current: Signal application only, 1.5 amperes per contact at 70°C (fully loaded)
- Temperature: -55 to 125°C
- Air/creepage distance: 0.8mm minimum

3.4. Performance and Test Description

Product is designed to meet electrical, mechanical and environmental performance requirements specified in Figure 1. Unless otherwise specified, all tests shall be performed at ambient environmental conditions per IEC 512-1.

3.5. Test Requirements and Procedures Summary

Test Description	Requirement	Procedure
Examination of product.	Meets requirements of product drawing.	IEC 512-2-1a. Visual, dimensional and functional per applicable quality inspection plan.
ELECTRICAL		
Termination resistance.	50 milliohms maximum initial. ΔR 5 milliohms maximum.	IEC 512-2-2a. Subject mated contacts assembled in housing to 20 mv maximum open circuit at 100 ma maximum. See Figure 3.
Dielectric withstanding voltage.	750 vac at sea level.	IEC 512-2-4a, Method B. Test between 2 groups of alternate contacts of mated samples. Test between first group and second group connected to the housing or mounting plate. Then test between second group and first group connected to the housing or mounting plate. See Figure 4.
Insulation resistance.	10000 megohms minimum initial. 1000 megohms minimum final.	IEC 512-2-3a, Method A. Test between each termination being tested and all others connected together, and between each termination being tested and the housing or mounting plate of mated samples.
MECHANICAL		
Vibration, sinusoidal.	No discontinuities of 1 microsecond or longer duration. See Note.	IEC 512-4-6d. Subject mated samples to 10-500-10 Hz traversed in 6.27 minutes. 5.66 hours in each of 3 mutually perpendicular planes. See Figure 5.
Physical shock.	No discontinuities of 1 microsecond or longer duration. See Note.	IEC 512-4-6c. Subject mated samples to 50 G's half-sine shock pulses of 11 milliseconds duration. 5 shocks in each direction applied along 3 mutually perpendicular planes, 30 total shocks. See Figure 5.

Figure 1 (continued)

Test Description	Requirement	Procedure
Polarization force.	100 Newtons (22.48 pounds) minimum. See Note.	IEC 512-7-13e. Attempt to mate samples oriented 180° out of phase at maximum rate of 12.7mm (.5 inch) per minute.
Mating force.	.75 Newton (2.7 ounces) maximum per contact. See Note.	IEC 512-7-13e. Measure force necessary to mate samples at maximum rate of 12.7mm (.5 inch) per minute.
Unmating force.	.15 Newton (.5 ounce) minimum per contact. See Note.	IEC 512-7-13e. Measure force necessary to unmate samples at maximum rate of 12.7mm (.5 inch) per minute.
Contact retention force.	5 Newtons (1.1 pounds) minimum in mating direction. 10 Newtons (2.2 pounds) minimum in unmating direction. See Note.	IEC 512-8-15a. Subject 20% of contacts to axial load in both directions at maximum rate of 10 Newtons per second until specified load is reached and hold for 10 seconds.
Module retention force.	74 Newtons (16.62 pounds) minimum. See Note.	IEC 512-5-8a. Measure force required to separate module from housing. See Figure 6.
ACTION PIN contact retention force.	20 Newtons (4.49 pounds) minimum. See Note.	IEC 512-8-15a. Measure force required to separate ACTION PIN from the printed circuit board.
Gage retention force.	15 grams (.53 ounce) minimum. See Note.	IEC 512-8-16e, Method A. Insert and remove a .381mm (.015 inch) gage 3 times. Then insert a .355mm (.014 inch) gage and measure force required to remove. See Figure 7.
Durability.	See Note.	IEC 512-5-9a. Mate and unmate samples for 250 cycles at maximum rate of 600 cycles per hour.
ENVIRONMENTAL		
Thermal shock.	See Note.	IEC 512-6-11d. Subject mated samples to 5 cycles between -55 and 125°C.
Humidity-temperature cycling.	See Note.	IEC 512-6-11c, 11j, and 11m. Subject mated samples to 6, 24 hour cycles between 25 and 40°C at 95% RH with -55°C cold shock.
Humidity, steady state.	See Note.	IEC 512-6-11c. Subject mated samples to steady state humidity of 93% and 40°C for 21 days.

Figure 1 (continued)

Test Description	Requirement	Procedure
Corrosion atmosphere.	See Note.	IEC 68-2-60. Subject mated and unmated samples to corrosion atmosphere for 4 days.
Temperature life and electrical load.	See Note.	IEC 512-6-11i. Subject mated samples to temperature life at 87.5°C for 1000 hours while energized with 1.25 amperes DC.

NOTE

Shall meet visual requirements, show no physical damage and shall meet requirements of additional tests as specified in Test Sequence in Figure 2.

Figure 1 (end)

3.6. Product Qualification and Requalification Test Sequence

Test or Examination	Test Group (a)					
	1	2	3	4	5	6
	Test Sequence (b)					
Examination of product	1,19	1,14	1,11	1,10	1,3	1,5
Termination resistance	2,16	2,8,10	2,8	2,7		
Dielectric withstanding voltage	4,12,15	4,12	4,7	4,9		
Insulation resistance	3,11,14	3,11	3,6	3,8		
Vibration	8					
Physical shock	9					
Polarization force						2
Mating force	5,17		9			
Unmating force	6,18		10			
Contact retention force						4
Module retention force						3
ACTION PIN contact retention force					2	
Gage retention force	7	5,13				
Durability		6,9		5		
Thermal shock	10					
Humidity-temperature cycling	13					
Humidity, steady state			5			
Corrosion atmosphere		7				
Temperature life & electrical load				6		

NOTE (a) See paragraph 4.1.A.
 (b) Numbers indicate sequence in which tests are performed.

Figure 2

4. QUALITY ASSURANCE PROVISIONS

4.1. Qualification Testing

A. Sample Selection

Samples shall be prepared in accordance with applicable Instruction Sheets and shall be selected at random from current production. Test groups 1, 2, 3, 4, and 5 shall each consist of 3, 200 position male assemblies and 4, 200 position female assemblies. Test group 6 shall consist of 4, 176 position male assemblies and 4, 176 position female assemblies.

B. Test Sequence

Qualification inspection shall be verified by testing samples as specified in Figure 2.

4.2. Requalification Testing

If changes significantly affecting form, fit or function are made to product or manufacturing process, product assurance shall coordinate requalification testing, consisting of all or part of original testing sequence as determined by development/product, quality and reliability engineering.

4.3. Acceptance

Acceptance is based on verification that product meets requirements of Figure 1. Failures attributed to equipment, test setup or operator deficiencies shall not disqualify product. When product failure occurs, corrective action shall be taken and samples resubmitted for qualification. Testing to confirm corrective action is required before resubmittal.

4.4. Quality Conformance Inspection

The applicable quality inspection plan will specify sampling acceptable quality level to be used. Dimensional and functional requirements shall be in accordance with applicable product drawing and this specification.

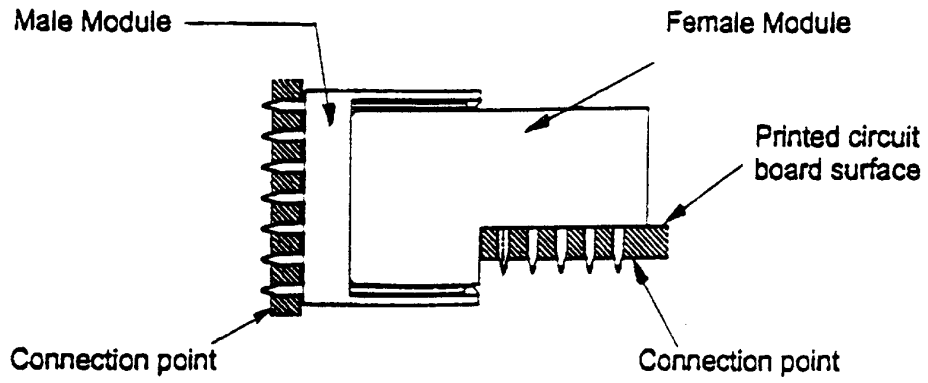

Figure 3
Termination Resistance Measurement Points

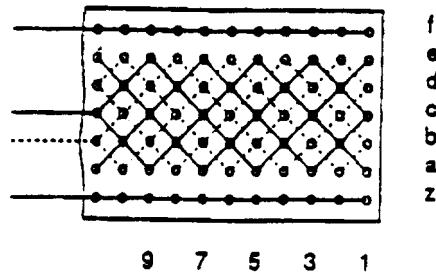

Figure 4
Dielectric Withstanding Voltage Wiring Arrangement

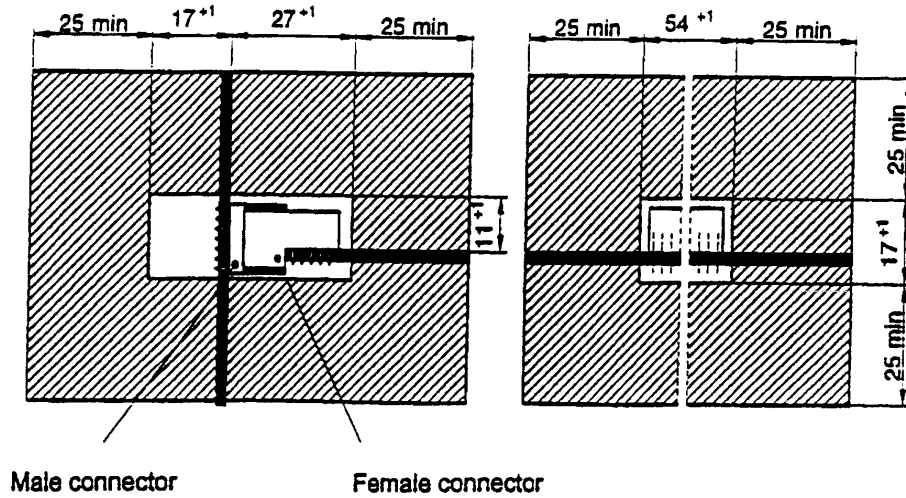

Figure 5
Vibration & Physical Shock Mounting Fixture

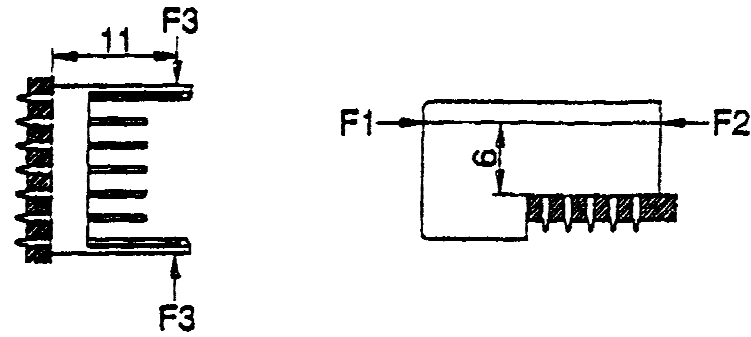
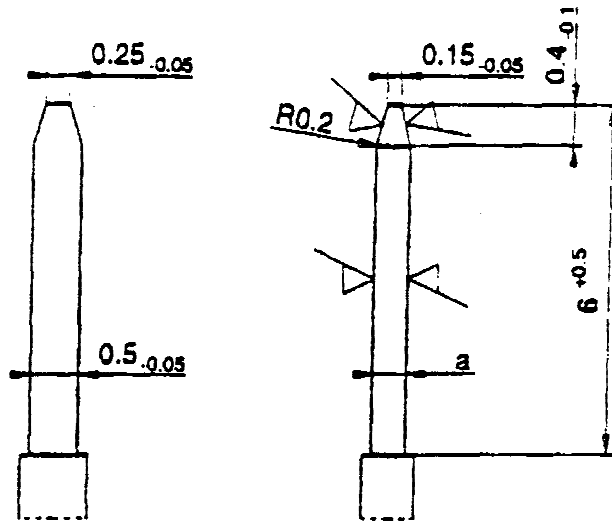

Figure 6
Module Retention Force



Application	"A" Dimension	Mass (grams)
Sizing	0.04 to 0.39	-
Retention Force	0.36 to 0.35	16 to 15

Figure 7
Gage Retention Force

Test	TE Test Specification	IEC Specification
Examination of product		512-2-1a
Termination resistance	109-6-6, Condition F	512-2-2a
Dielectric withstanding voltage	109-29-1	512-2-4a, Method B
Insulation resistance	109-28-3, Condition C	512-2-3a, Method A
Vibration	109-21-2, Condition B	512-4-6d
Physical Shock	109-26-1	512-4-6c
Polarization force	109-42, Condition A	512-7-13e
Mating force	109-42, Condition A	512-7-13a
Unmating force	109-42, Condition A	512-7-13a
Contact retention force	109-30	512-8-15a
Module retention force	109-30	512-5-8a
ACTION PIN contact retention force	109-30	512-8-15a
Gage retention force	109-30	512-8-16e, Method A
Durability	109-27	512-5-9a
Thermal shock	109-22	512-6-11d
Humidity-temperature cycling	109-23-3	512-6-11c, 11j , 11m
Humidity, steady state	109-23-2	512-6-11c
Corrosion atmosphere	109-85	68-2-60
Temperature life & electrical load	109-43	512-6-11i

Figure 8
Qualification Test Cross Reference

单击下面可查看定价，库存，交付和生命周期等信息

[>>TE Connectivity\(泰科\)](#)