



---

## AMP DUOPLUG POWER

---

### 1. SCOPE

#### 1.1. Content

This specification covers the performance, tests and quality requirements for the AMP DUOPLUG POWER connectors  
(compare Fig. 1)

PN: 1394918

PN: 1534415

PN: 1740533 (only for PCB application)

Mating Parts:

a) Tab header PN: 1534787 / 1534788 (comp. Fig. 2)

b) PCB (compare Fig. 4) with AMP DUOPLUG 2.5 FRAME PN 964575 / 964576 (comp. Fig. 3)

#### 1.2. Qualification

When tests are performed on the subject product line, procedures specified in **Error! Reference source not found.** shall be used. All inspections shall be performed using the applicable inspection plan and product drawing.

### 2. APPLICABLE DOCUMENTS AND FORMS

The following documents form a part of this specification to the extent specified herein. In the events of conflict between the requirements of this specification and the product drawing or of conflict between the requirements of this specification and the referenced documents, this specification shall take precedence.

#### 2.1. TE Documents

A Customer Drawings and Name- PN's see item 1.1

B Application Specification- 114-18458-1

#### 2.2. Other Documents

- |   |                |   |
|---|----------------|---|
| A | IEC 60112      | Method for determination the comparative and the poof tracking indices<br>edition 11/2003   |
| B | IEC 60695-2-11 | Fire hazard testing<br>edition 11/2001  |
| C | IEC 60998-1    | Connector devices for low-voltage circuits for household and similar purposes;<br>Part 1: General requirements<br>edition 04/1994                 |
| D | IEC 60998-2-3  | Connector devices for low-voltage circuits for household and similar purposes;<br>Part 2-3 insulation-piercing clamping units.<br>edition 09/1994 |
| E | IEC 60068-1    | Environmental testing – General and guidance  |

F	IEC 60512	Measuring methods and testing procedures for electromechanical components edition....
G	ISO 6988	Testing in a saturated atmosphere in the presence of dioxide edition 03/1997
H	IEC 61984	Connectors- Safety requirements and tests edition 09/2002

### 2.3. Reference Documents

109-1	General Requirements for Testing
102-950	Qualification of Separable Interface Connectors

## 3. REQUIREMENTS

### 3.1. Design and Construction

Product shall be of the design, construction and physical dimensions specified on the applicable production drawing.

### 3.2. Materials

Descriptions for material see in production drawings.

### 3.3. Ratings

A Voltage:	250V/AC
B Current carrying capability:	see applicable current carrying capability, Figure 1 and table *)
C Temperature:	-40 to +110°C **)
D Degree of Protection:	IP 00
E Durability:	10 cycles

\*) max. 4 contacts with 6 A side by side

\*\*) ambient temperature max. 85°C

### 3.4. Performance Requirements and Test Description

The product is designed to meet the electrical, mechanical and environmental performance requirements specified in Para. 3.5. All tests are performed at ambient environmental conditions per IEC 60512-1 unless otherwise specified.

Preparation for all Test Groups:

Storage 1 day at 50% rel. humidity acc. to IEC 60068-1.

Temperature: 25 ± 10°C

Rel. Humidity: 45 - 75%

Air pressure: 860 - 1060 mbar

## 3.5. Test Requirements and Procedure Summary

Test Description	Requirement	Procedure
Visual- and dimensional examination	Meets requirements of product drawing	Acc. to IEC 60512-1-1/-1-2
<b>ELECTRICAL INSPECTIONS</b>		
Current-temperature capability	See applicable current carrying capability (Figure 9/10)	Acc. to IEC 60512-5-2
Max. temperature rise of ID. (Wire length 250 mm)	$\Delta T \leq 45^{\circ}\text{C}$	Acc. to IEC 60998 Part 1, Test 15.4 Current: 6A (9A) Wire Size 0,5mm <sup>2</sup> (0,75mm <sup>2</sup> )
Temperature rise test	$T \leq 110^{\circ}\text{C}$	Acc. to IEC 60512-5-1 See applicable current carrying capability
Voltage proof	Value and nature of the test voltage: 1390 V	Acc. to IEC 60512-4-1
Insulation resistance	Value and nature of the test voltage: 500 V DC 5 megaohms minimum <i>min. 5 MOhm</i>	Acc. to IEC 60998 Part 1, Test 13.3 Duration: 60 s
Measuring of resistance (Figure 5/6)	Over all resistance $R_i \leq 10\text{m}\Omega$ $R \leq 1.5 \times R_i$ (new/neu) or $\leq R_i + 5\text{m}\Omega$ $R_i = R_{\text{initial}}$ (the higher value is acceptable)	Acc. to IEC 60512-2-2 Current: 1 A
Measuring of voltage drop (Figure 7 / 8)	Connecting voltage drop  $UIDC \leq 22,5\text{mV}$ or $U_{\text{overall}} \leq 50,0\text{mV}$	Acc. to IEC 60998 Part 2-3, Test 15.101, measuring the UIDC (voltage drop on IDC only) considering the requirement on the left.  As alternative, to measure at the same current the $U_{\text{overall}}$ (voltage drop on the overall circuit = IDC+ bulk + mating) considering the requirement on the left.

<b>MECHANICAL INSPECTIONS</b>		
Engaging- and separating forces of contact (on Tab header) Polished steel Tab 1,5mm	Connect: max. 6N Disconnect: min. 1N	Acc. to IEC 60512-7, Test 13a Actuating Speed: 25 mm/min Number of Mating/Unmating: 1
Contact retention in insert: holding force of the contacts in the connector (connector with terminated wire and closed cover)	Socket: min. 20 N <i>or min. 3x Insertion force</i> (the higher value is acceptable)	Acc. to IEC 60512-8, Test 15a Testing speed: 25mm/min
Tensile strength of termination (90° to mating direction) IDC area	Tensile force : 30 N – 0.35mm <sup>2</sup> 50 N – 0.50mm <sup>2</sup> 50 N – 0.75mm <sup>2</sup>	Acc. to IEC 60998 Part 2-3, Test 14.101.2.2 Testing speed: 25 mm/min
Polarization method	Mating force: min. 20 N	Acc. to IEC 60512, Part 7, Test 13e
Engaging- and separating of Connector	No physical damage	Acc. to IEC 61984, Test 7.3.8 Number of Engaging/Separating: 10
Impact Tests	No physical damage	Analog to IEC 60512-5 / 05.94 Test 7b Single fall for all 3 room axis from a height of 1m onto uncoated concrete floor at room temperature
Wire movement	No impermissible shift or break near the Contact of the wire	Acc. IEC 60998 Part 2-3, Test 14.101.1 $\varnothing=6,5\text{mm}/H=260\text{mm}/F=3\text{N}$

ENVIRONMENTAL INSPECTIONS		
Thermal cycling	No physical damage UIDC $\leq$ 22,5mV or U <sub>overall</sub> $\leq$ 50,0mV	Acc. to IEC 60998 Part 2-3, Test 15.101, considering the requirements on the left.  T <sub>a</sub> = 30°C T <sub>b</sub> = 85°C Number of cycles: 192
Corrosion	No physical damage	Saturated atmosphere in the presence of sulphur dioxide acc. to EN ISO 6988-0.2s  T = 40° 0,2 dm <sup>3</sup> SO <sub>2</sub> 2 dm <sup>3</sup> H <sub>2</sub> O Duration time: 8 hours  As alternative, Mixed flowing gas acc. to IEC 60512-11-7 Method 1 or Method 4.
Dry Heat	No physical damage	Acc. to IEC 60512-11-9  T=110°C Duration time: 7 Days
Cold	No physical damage	Acc. to IEC 60512-11-10  T = -40°C Duration time: 2 Hours
Ball pressure test	$\varnothing \leq 2$ mm	Acc. to IEC 60998 Part 1, Test 16.3  T= 125°C/ 1 hour
Glow wire test	Flame time t <sub>f</sub> $\leq$ 30s No inflame of the tissue-paper/ Measure of flame height	Acc. to IEC 60695-2-11  T=850°C (T=650°C for Frame)
Proof Tracking Index	250	Acc. IEC 60112, test liquid A

**NOTE**

Shall meet visual requirements, show no physical damage, and meet requirements of additional tests as specified in the Product Qualification and Requalification Test Sequence shown in Figure 1.

3.6. Product Qualification and Requalification Test Sequence

Test	Test Group <sup>1)</sup>													
	A	B	C	D	E	F	G	H	J	K	L	M	N	
	Test Sequence <sup>2)</sup>													
Visual- and dimensional examination	1				1									
Current-temperature capability			2											
Max. Temperature rise of ID.									1					
Max. Temperature rise of contacts			3											
Voltage proof			5	6										
Insulation resistance														
Measuring of resistance		1/3	1/4	1/5										
Measuring of voltage drop										1/3				
Engaging- and separating forces of contact	2													
Contact retention in insert	3													
Tensile strength of termination							1							
Polarization method					2									
Engaging- and separating of Connector		2												
Impact Test								1						
Wire movement						1								
Thermal cycling										2				
Corrosion				4										
Dry Heat				3										
Cold				2										
Ball pressure test											1			
Glow wire test												1		
Proof Tracking Index													1	

Figure 1



**NOTE**

- 1) See Para.4.1 A
- 2) Numbers indicate sequence in which tests are performed.

## 4. QUALITY ASSURANCE PROVISIONS

### 4.1 Qualification Testing

#### A Sample Selection

The samples shall be prepared in accordance with product drawings. They shall be selected at random from current production.

Test Groups shall consist of:

Test Group A:	3	contacts
Test Group B:	3	contacts
Test Group C:	9x3	9 pos. Hsg. complete loaded
Test Group D:	3	without contacts
Test Group E:	3	contacts
Test Group F:	3x2	min. and max. cross-section
Test Group G:	3x2	min. and max. cross-section
Test Group H:	9x3	contacts
Test Group J:	9x3	contacts
Test Group K:	9x3	contacts
Test Group L:	/	contacts
Test Group M:	x3	contacts
Test Group N:	/	without contacts

Test Group A:	1	connectors
Test Group B:	1	connectors
Test Group C:	3	connectors
Test Group D:	1	connectors
Test Group E:	2	connectors
Test Group F:	2	connectors
Test Group G:	2	connectors
Test Group H:	3	connectors
Test Group J:	3	connectors
Test Group K:	3	connectors
Test Group L:	3	connectors
Test Group M:	3	connectors
Test Group N:	3	connectors

#### B Test Sequence

Qualification inspection shall be verified by testing samples as specified in Para. 3.6.

#### 4.2. Requalification Testing

If changes significantly affecting form, fit, or function are made to the product or to the manufacturing process, product assurance shall coordinate requalification testing, consisting of all or part of the original testing sequence as determined by development/product, quality, and reliability engineering.

#### 4.3. Acceptance

Acceptance is based on verification that the product meets the requirements of Para. 3.5. Failures attributed to equipment, test setup, or operator deficiencies shall not disqualify the product. When product failure occurs, corrective action shall be taken and samples resubmitted for qualification. Testing to confirm corrective action is required before resubmittal.

#### 4.4. Quality Conformance Inspection

The applicable quality inspection plan shall specify the sampling acceptable quality level to be used. Dimensional and functional requirements shall be in accordance with the applicable product drawing and this specification.



Figure 1  
Female connector

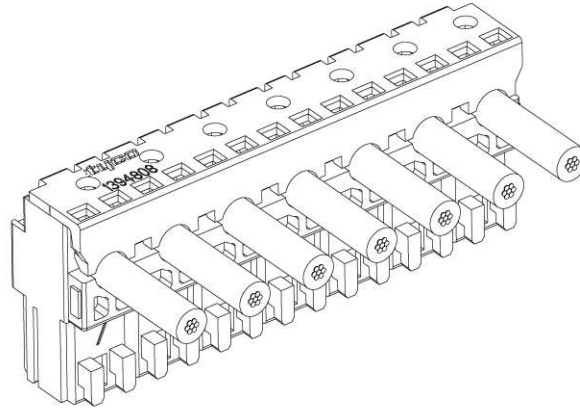

Typical design of PNs 1394918, 1534415, 1740533

Figure 2  
Tab Header

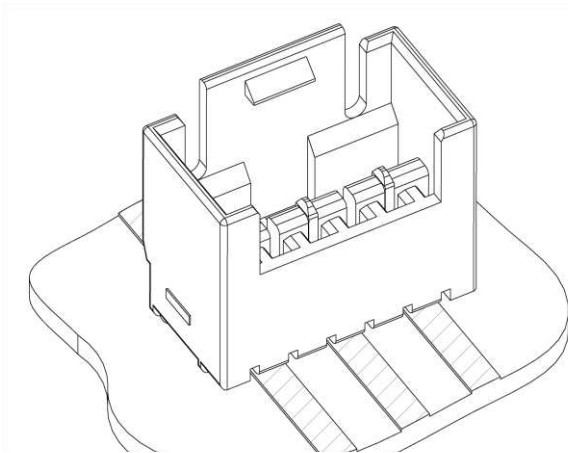

Figure 3  
PCB Frame

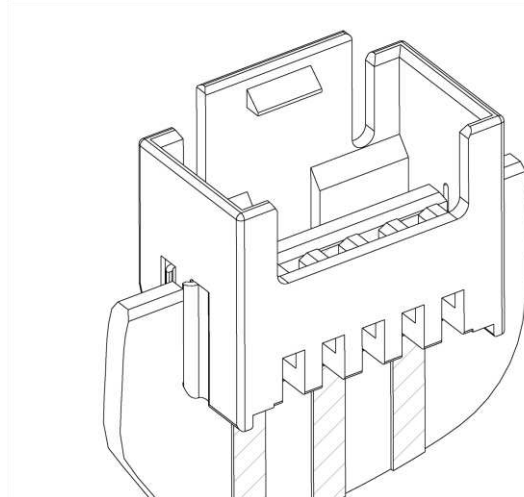
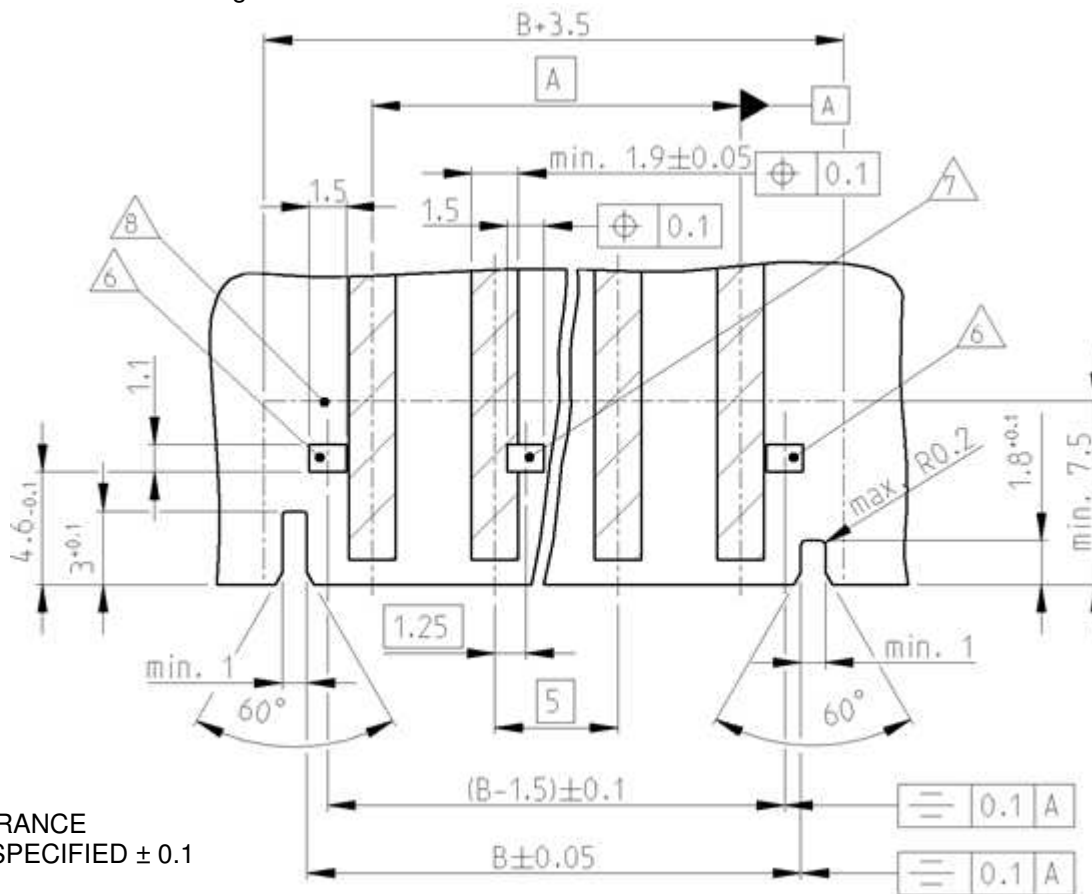

Figure 4



- 1 BASE MATERIAL QUALITY: CEM1, FR-4
- 2 PCB THICKNESS:  $1.5 \pm 0.14$  (BASE MATERIAL INCL. COPPER CLADDING, SINGLE OR DOUBLE SIDED)
- 3 COPPER COATING THICKNESS: 35-70  $\mu\text{m}$
- 4 PLATING: 5-20  $\mu\text{m}$  ELECTRODEPOSITED Sn OR SnPb 60/40-93/7 OR EQUIVALENT HAL TREATMENT
- 5 NO Ni UNDERPLATING

LOCKING WINDOW ALWAYS PRESENT

ADDITIONAL LOCKING CLIP BETWEEN CAVITY NO. SEE DRAWING 964 575

AREA FOR FRAME

POS. POLZAHL	DIM A MASS A	DIM B MASS B
2	5	9,9
3	10	14,9
4	15	19,9
5	20	24,9
6	25	29,9
7	30	34,9
8	35	39,9
9	40	44,9

Resistance measurement  
Figure 5

$$R = R_g - R_{50\text{mm Wire}}$$

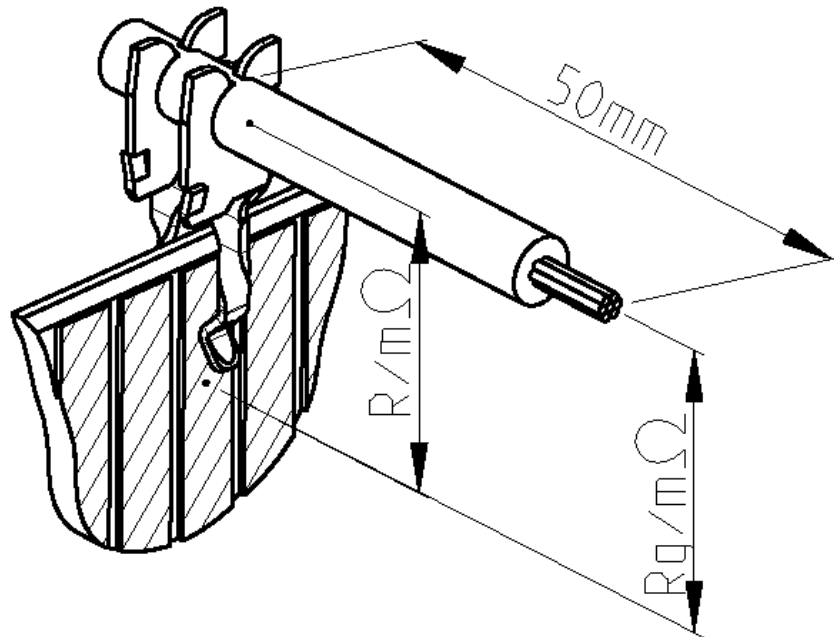

Resistance measurement  
Figure 6

$$R = R_g - R_{50\text{mm Wire}}$$

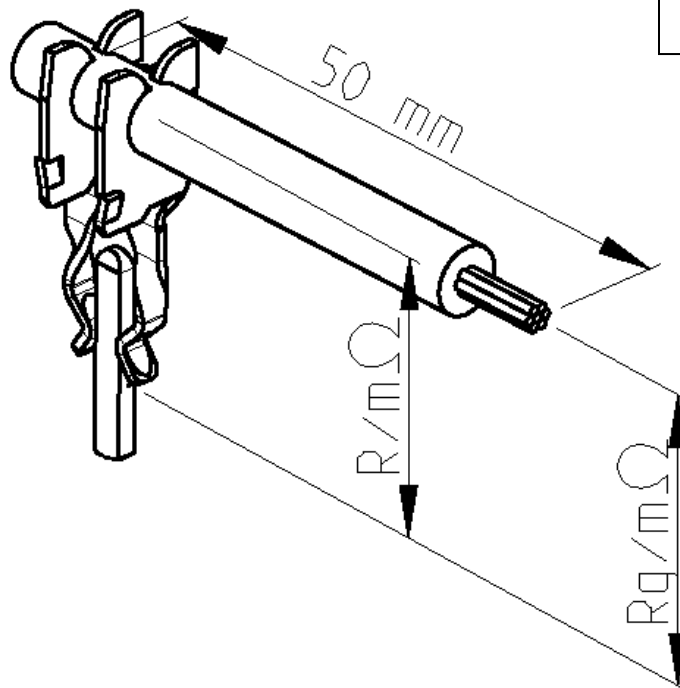

Voltage drop measurement  
Figure 7

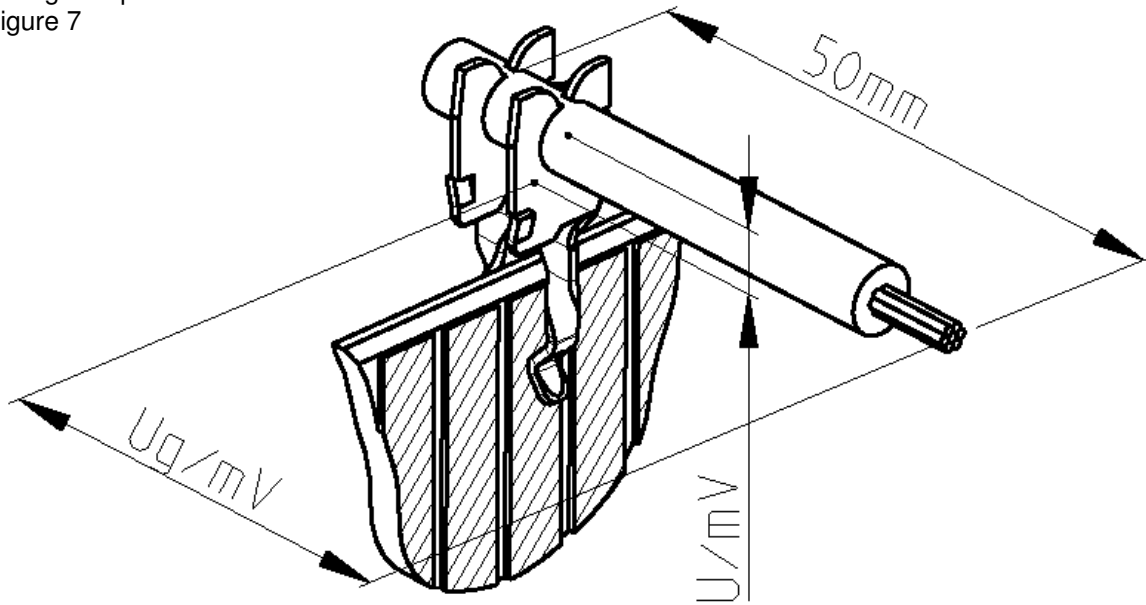

$$U = U_g - U_{50mm \text{ Wire}}$$

Voltage drop measurement  
Figure 8

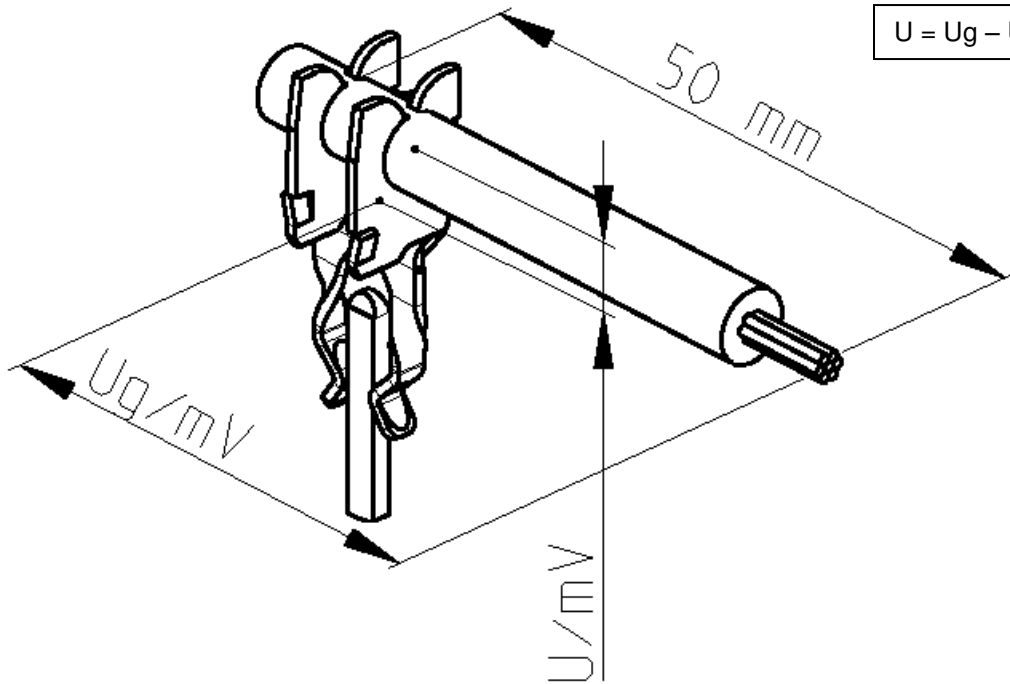

$$U = U_g - U_{50mm \text{ Wire}}$$

## DUOPLUG POWER CONNECTOR

Application on Tabheader and PCB /  
Anwendung auf Stiftwanne und LP

**tyco** Electronics / **AMP**  
BENSHEIM  
21 January 2002

Connector/Stecker (PN): 1394918-9  
 Receptacle/Buchse: DUOPLUG Power Contact  
 Material Contact: Cu/Ni/Si / Sn  
 Material housing/Material Gehäuse: PA 66  
 Cross Section / Leiterquerschnitt: 0.35 mm<sup>2</sup>  
 Application Tool / Anschlagwerkzeug: Prototyp Servicatool  
 Mating part / Gegenstecker: Tabheader (1534788)  
 Material Tabheader / Material Stiftwanne: PCB (single or double sided / LP (ein- und beidseitig)  
 (Copper coating 35µm / Kupferschicht 35 µm)  
 Cu/Zn, tinned / CuZn, verzinnend  
 PBT - GF  
 Test layout / Testaufbau: 3x3 position / 3 x 9 polig

**Legend/Erklärung**  
 Curve 1: PCB one sided 35µm  
 Kurve 1: LP einseitig 35 µm  
 Curve 2: PCB double sided 35µm  
 Kurve 2: LP beidseitig 35 µm  
 Curve 3: Tabheader  
 Kurve 3: Stiftwanne

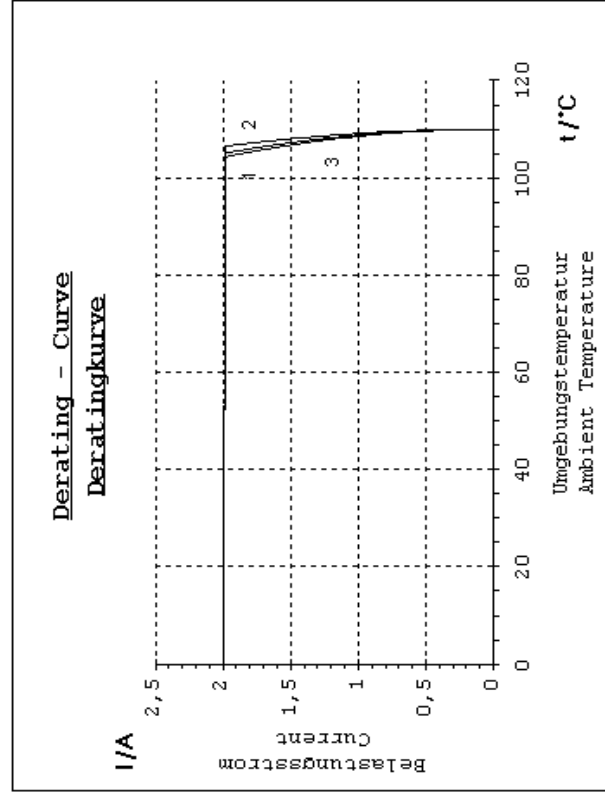
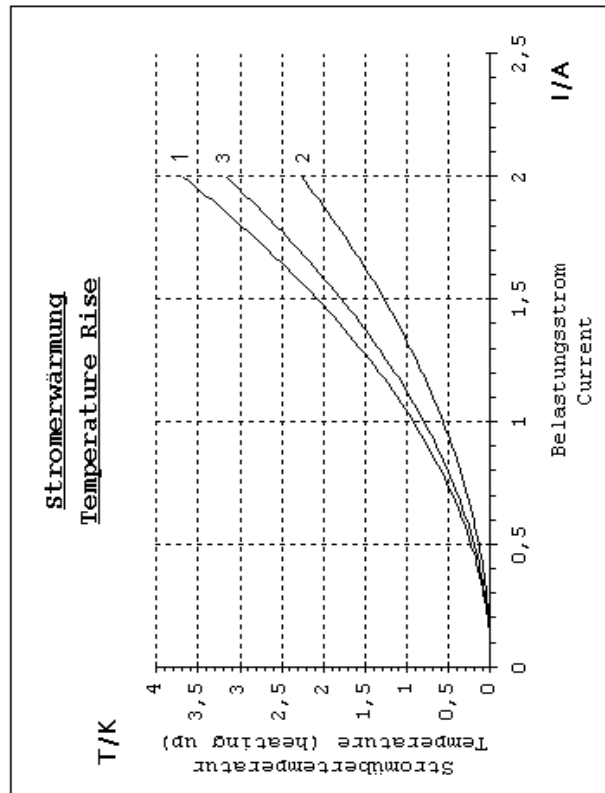

# DUOPLUG POWER CONNECTOR

Application on Tabheader and PCB /  
Anwendung auf Stiftwanne und LP

- Connector/Stecker (PN): 1394918-9
- Receptacle/Buchse: DUOPLUG Power Contact
- Material Contact: CuNiSi/Sn
- Material housing/Material Gehäuse: PA 66
- Cross Section / Leiterquerschnitt: 0.50 mm<sup>2</sup>
- Application Tool / Anschlagwerkzeug: Prototyp Servicetool
- Mating part / Gegenstecker: Tabheader (1534788)
- Material Tabheader / Material Stiftwanne: PCB (single or double sided / LP (ein- und beidseitig) (Copper coating 35µm / Kupferschicht 35 µm) CuZn, tinned / CuZn, verzinnmed PBT - GF
- Test layout / Testaufbau: 3x9 position / 3 x 9 polig

Figure 10



Legend / Erklärung
Curve 1: PCB one sided 35µm Kurve 1: LP einseitig 35 µm
Curve 2: PCB double sided 35µm Kurve 2: LP beidseitig 35 µm
Curve 3: Tabheader Kurve 3: Stiftwanne

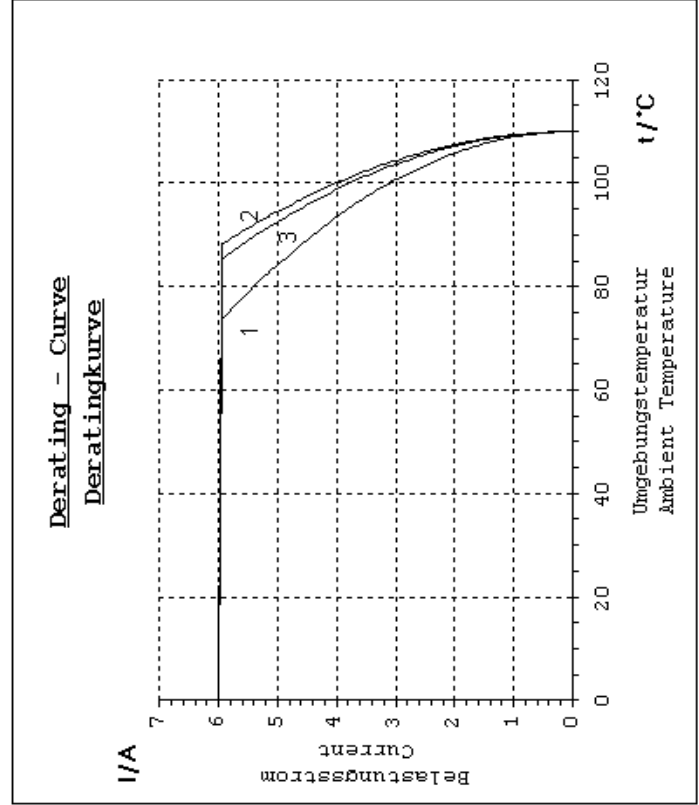
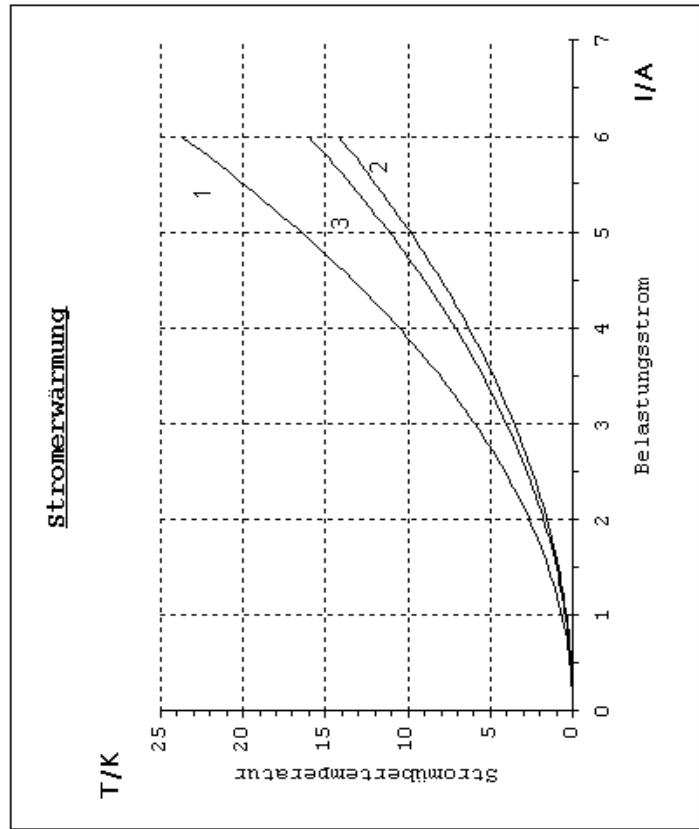

## AMP Duoplug 2,5 Power with pcb locking

Tyco Electronics
   
 Test Competence Center EMEA

BUCHSE (PN) : 0-1740533-9  
 MATERIAL : PA6 GF, CuNiSi  
 LEITERQUERSCHNITT : 0,75mm<sup>2</sup> Telefonika TT1-4108  
 ANSCHLAGWERKZEUG : SIM 25E  
 LEITERPLATTE (PN) : AT&S Test-PCB(einseitig), EGGSN05504-2300-01  
 MATERIAL : CEM1  
 SCHICHTDICKE : 35µm  
 MESSAUFBAU : 3 Testmuster / Derating 6A / alle Kontakte bestromt



### Stromerwärmung

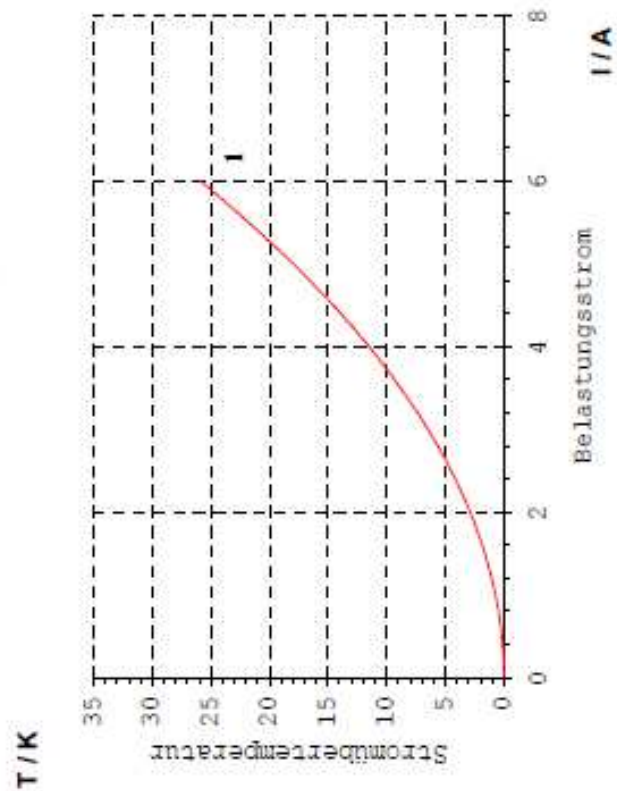

### Derating - Kurve

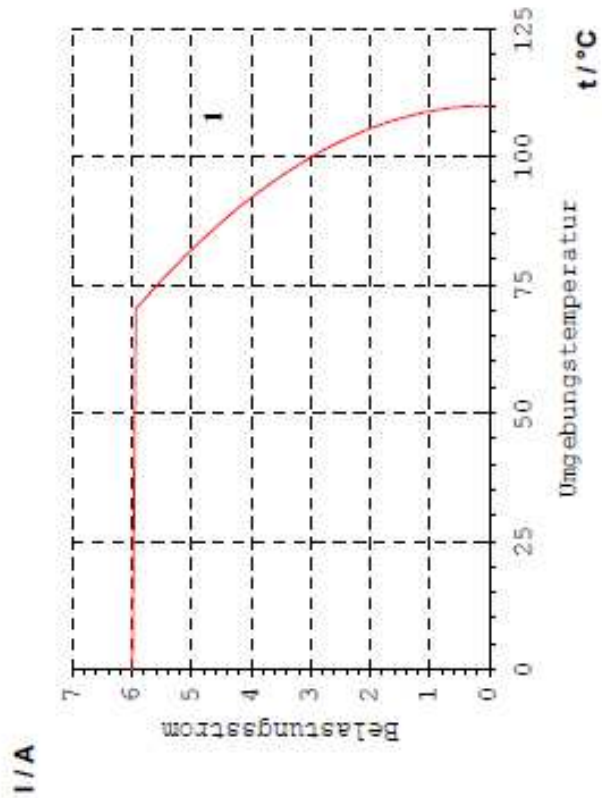

单击下面可查看定价，库存，交付和生命周期等信息

[>>TE Connectivity\(泰科\)](#)