Cluster Block Assembly

1. SCOPE

1.1. Content

This specification covers the general description and performance requirements for TE Connectivity (TE) cluster block assemblies designed to connect with hermetic headers having 2.29 and 3.18 mm [.090 and .125 in] diameter pins. The assembly consists of a 2, 3 or 4 position housing accepting terminals with various wire and insulation diameter ranges.

1.2. Qualification

When tests are performed on the subject product line, procedures specified in Figure 1 shall be used. All inspections shall be performed using the applicable inspection plan and product drawing.

2. APPLICABLE DOCUMENTS

The following documents form a part of this specification to the extent specified herein. Unless otherwise specified, the latest edition of the document applies. In the event of conflict between the requirements of this specification and the product drawing, the product drawing shall take precedence. In the event of conflict between the requirements of this specification and the referenced documents, this specification shall take precedence.

2.1. TE Documents

- ! 109-1: Test Specification (General Requirements for Test Specifications)
- ! 109 Series: Test Specifications as indicated in Figure 1
- ! 114-2019: Application Specification (Cluster Block Housings and Contacts)

2.2. Industry Documents

- ! ASTM D3455: Standard Test Methods for Compatibility of Construction Material with Electrical Insulating Oil of Petroleum Origin
- ! EIA-364: Electrical Connector/Socket Test Procedures Including Environmental Classifications
- ! IEC-60512: Electronic Equipment - Tests and Measurements

3. REQUIREMENTS

3.1. Design and Construction

Product shall be of the design, construction and physical dimensions specified on the applicable product drawing.

3.2. Materials

Materials used in the construction of this product shall be as specified on the applicable product drawing.

3.3. Ratings

- ! Voltage: 115/230 volts AC at 60 Hz
- ! Current: The maximum rated current that can be carried by this product is limited by the maximum operating temperature of the housings and the temperature rise of the contacts. Variables which shall be considered for each application are wire size, connector size, contact material and ambient temperature.

3.4. Performance and Test Description

Product is designed to meet the electrical, mechanical and environmental performance requirements specified in Figure 1. Unless otherwise specified, all tests shall be performed at ambient environmental conditions per Test Specification 109-1.

3.5. Test Requirements and Procedures Summary

Test Description	Requirement	Procedure																
Examination of product.	Meets requirements of product drawing and Application Specification 114-2019.	Visual, dimensional and functional per applicable inspection plan.																
ELECTRICAL																		
Dielectric withstanding voltage.	2.7 kilovolts AC at sea level. 1 second hold.	EIA-364-20 and IEC 60512-4-1. Test between adjacent terminals of mated samples.																
Temperature rise vs current.	See Figure 3.	EIA-364-70, Method 1. Measure temperature rise at rated current. See Figure 4.																
MECHANICAL																		
Crimp tensile.	<table border="0"> <tr> <td>Stranded Wire</td> <td>Tensile</td> </tr> <tr> <td>Size (AWG)</td> <td>(N [lbf] min)</td> </tr> <tr> <td>22</td> <td>44 [10]</td> </tr> <tr> <td>18</td> <td>110 [25]</td> </tr> <tr> <td>16</td> <td>160 [37]</td> </tr> <tr> <td>14</td> <td>250 [57]</td> </tr> <tr> <td>12</td> <td>310 [70]</td> </tr> <tr> <td>10</td> <td>350 [80]</td> </tr> </table> <p>Note: Tensile values for AMPLIVAR* crimp receptacles are 70% minimum of the wire strength.</p>	Stranded Wire	Tensile	Size (AWG)	(N [lbf] min)	22	44 [10]	18	110 [25]	16	160 [37]	14	250 [57]	12	310 [70]	10	350 [80]	EIA-364-8. Determine crimp tensile at a rate of 25.4 mm [1 in] per minute.
Stranded Wire	Tensile																	
Size (AWG)	(N [lbf] min)																	
22	44 [10]																	
18	110 [25]																	
16	160 [37]																	
14	250 [57]																	
12	310 [70]																	
10	350 [80]																	
Contact retention in housing. See Figure 6 for product list.	22 N [5 lbf] minimum for standard product. 60 N [14 lbf] minimum for high force product.	TE Spec 109-30. Apply an axial load to crimped contacts in housing by gripping the wire.																
Contact engaging force onto header.	133 N [30 lbf] maximum per cluster block assembly. See Note 1.	TE Spec 109-35. Measure force necessary to engage header using appropriate gage (3 pin gages equally spaced on a 13.46 ± 0.03 mm [.530 ± .001 in] diameter circle). See Figures 5 and 6.																

Test Description	Requirement	Procedure
Contact separating force from header.	12 N [2.75 lbf] minimum per contact. 36 N [8.25 lbf] minimum per cluster block assembly. See Note 1.	TE Spec 109-35. Measure force necessary to separate appropriate gage (3 pin gages equally spaced on a 13.46 ± 0.03 mm [.530 ± .001 in] diameter circle) from header. See Figures 5 and 6.

ENVIRONMENTAL

Heat resistance.	No signs of blistering, delamination or degradation of physical properties.	Subject connector housings to 163°C for 6 hours.
Weight loss.	15 milligrams maximum for 1 or 2 piece cluster block assembly. 5 milligrams maximum for cover plate (where applicable).	Determine weight loss as the average of no less than 10 samples using the following procedure: <ol style="list-style-type: none"> 1. Suspend the samples in a vacuum oven and bake at 138/160°C [280/320°F] for 6 hours to remove moisture. 2. Remove the samples from the oven and quickly place them in a desiccator containing anhydrous magnesium perchlorate or calcium chloride to cool for 1 hour. 3. Weigh the sample lot. 4. Replace the samples in the vacuum oven and bake at 120/122°C [248/252°F] for 24 hours. 5. Remove the samples from the oven and quickly place them in a desiccator containing anhydrous magnesium perchlorate or calcium chloride to cool for 1 hour. 6. Weigh the sample lot. 7. Calculate the average weight loss by subtracting the value recorded in step 3 from the value recorded in step 6 and dividing by the number of samples.

Test Description	Requirement	Procedure
Chemical requirements, housing.	Plastic shall not: 1. Exceed 3% dimensional change. 2. Form sludge in the test oil. 3. Cause the acidity of the oil to exceed .2 cc using .1 N of sodium hydroxide per 100 cc of oil after 2 hours at room temperature. 4. Cause the saponification number of the oil to exceed 0.01 cc. Note: These maximums are per sample tested.	To be performed on housings weighing approximately 4.5 to 5.5 grams [.16 to .20 oz] each. Measure overall dimensions (length, width and height). Dry for 16 hours at 105°C [221°F] per ASTM D3455. Using a suitable vessel, immerse housings in 55 cc [3.36 cu in] of deaerated compressor lube (Trane oil 00037 or equivalent) to a depth of 50% and place in an atmosphere of Freon 22 (340.2 g [12 oz]) at a pressure of approximately 517.11 kPa [75 psig]. Subject to 107°C [225°F] for 100 hours. Re-measure dimensions and then test acidity and saponification.

Note 1: Engaging/separating forces apply to 3-position only. Consult TE product engineering for others.

Figure 1

3.6. Product Test Sequence

Test or Examination	Test Group (a)							
	1	2	3	4	5	6	7	8
	Test Sequence (b)							
Examination of product	1	1	1	1	1	1	1	1
Dielectric withstanding voltage	2							
Temperature rise vs current		2						
Crimp tensile					2			
Contact retention in housing			2					
Contact engaging force onto header				2				
Contact separating force from header				3				
Heat resistance								2
Weight loss						2		
Chemical requirements, housing							2	

NOTE (a) See Paragraph 4.1.A.
 (b) Numbers indicate sequence in which tests are performed.

Figure 2

4. QUALITY ASSURANCE PROVISIONS

4.1. Qualification Testing

A. Sample Selection

Samples shall be prepared in accordance with applicable Instruction Sheets and shall be selected at random from current production. All test groups shall each consist of 10 cluster block housings or assemblies with a minimum of 1 assembly per wire size (except where the wire size is not a factor).

B. Test Sequence

Qualification inspection shall be verified by testing samples as specified in Figure 2.

4.2. Requalification Testing

If changes significantly affecting form, fit or function are made to the product or manufacturing process, product assurance shall coordinate requalification testing, consisting of all or part of the original testing sequence as determined by development/product, quality and reliability engineering.

4.3. Acceptance

Acceptance is based on verification that the product meets the requirements of Figure 1. Failures attributed to equipment, test setup or operator deficiencies shall not disqualify the product. If product failure occurs, corrective action shall be taken and specimens resubmitted for qualification. Testing to confirm corrective action is required before resubmittal.

4.4. Quality Conformance Inspection

The applicable quality inspection plan shall specify the sampling acceptable quality level to be used. Dimensional and functional requirements shall be in accordance with the applicable product drawing and this specification.

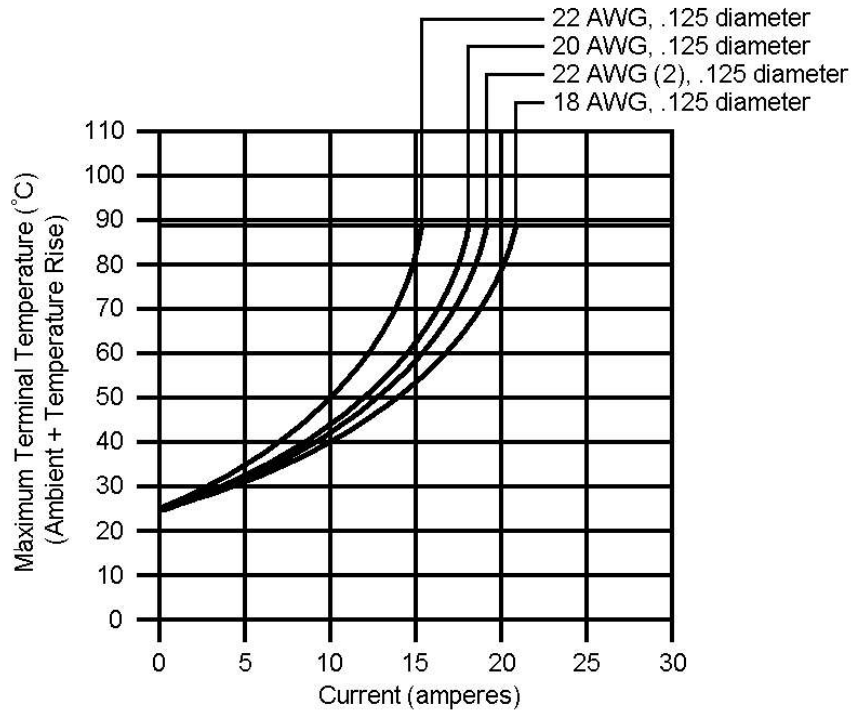
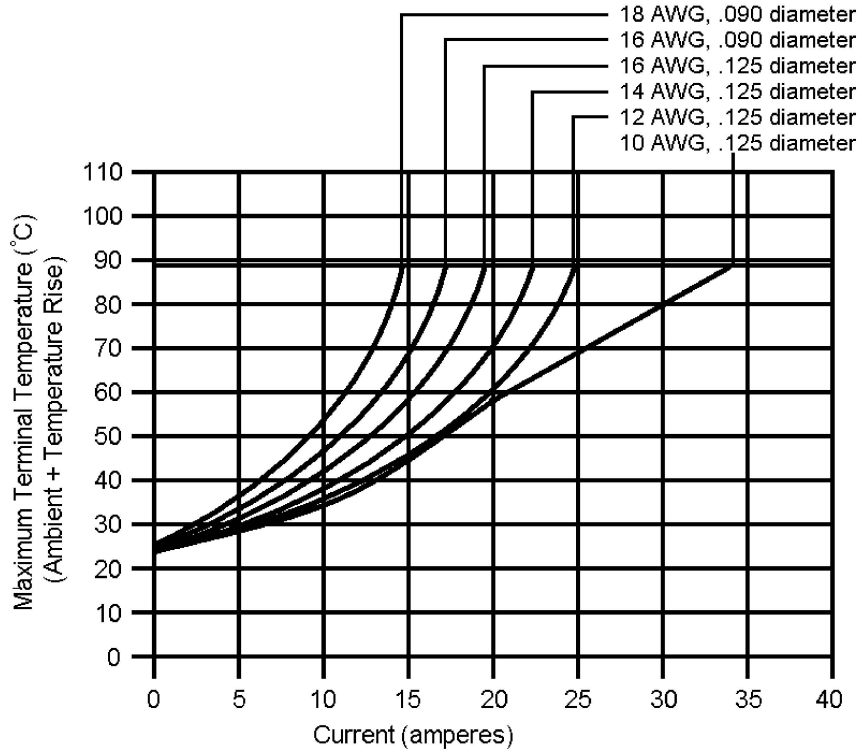
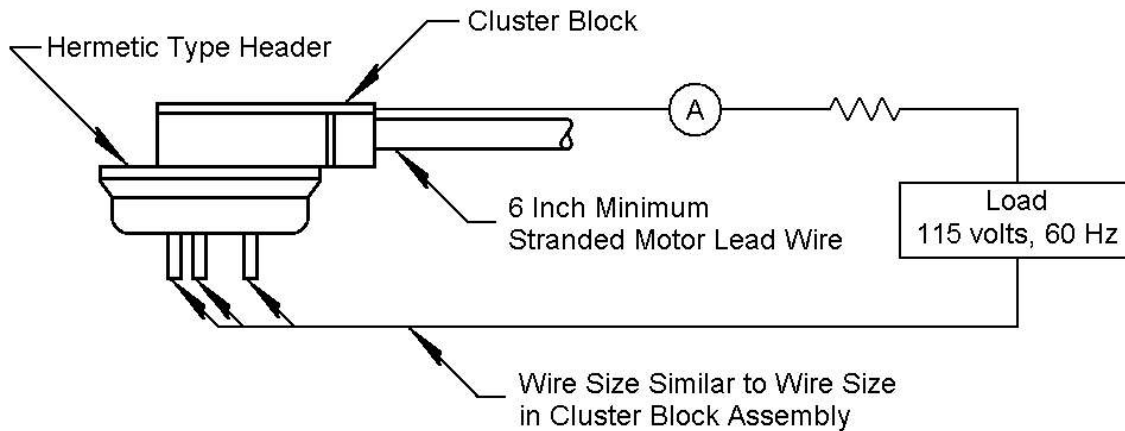
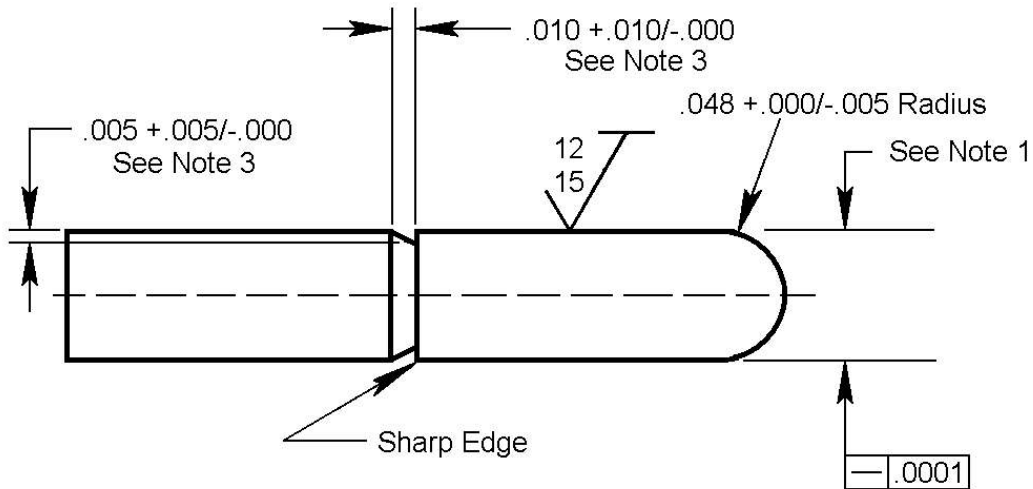

Figure 3
Temperature Rise vs Current Requirements



NOTE All terminals and leads shall be connected in series.

Figure 4
Temperature Rise vs Current Setup



- NOTE**
1. $.0890 +.0005/-.0000$ inch diameter pin is used to check $.090$ inch diameter cluster block pin receptacle. $.1240 +.0005/-.0000$ diameter pin is used to check $.125$ inch diameter cluster block receptacle.
 2. Material is steel alloy, Rockwell C60-65.
 3. Chamfer is optional.

Figure 5
Engaging/Separating Gages

Product Type	Receptacle Part Number
High Force Product	1217172
	1217173
	1217174
	1217175
	1217176
	1217264
	1217670
	1217671
	1217672
	1742096
	1742116
	1742117
	1742657
	1742964
	1742981

NOTE

Unless listed above, product is a Standard Force type with a 22 N [5 lbf] contact retention in the housing.

Figure 6

单击下面可查看定价，库存，交付和生命周期等信息

[>>TE Connectivity\(泰科\)](#)