MAG-MATE* Standard Series 187 and 300 Terminals

1. SCOPE

1.1. Content

This specification defines performance, tests, and quality requirements for MAG-MATE* Standard Series 187 and 300 Terminals. These terminals are designed for general use as a magnet wire to external circuit interface and are compatible with copper wire in sizes 17 through 32 AWG or aluminum wire in sizes 17 through 28 AWG. Coating of organic polymer material having NEMA temperature ratings of 105 to 200°C.

1.2. Qualification

When tests are performed on the subject product line, procedures specified in Figure 1 shall be used. All inspections shall be performed using the applicable inspection plan and product drawing.

1.3. Qualification Test Results

Successful qualification testing on the subject product line was completed on 14-Oct-85. Additional testing was completed on 05-Oct-07 and 30-Jun-08. The Qualification Test Report number for this testing is 501-30. Additional testing was also completed on 26-Sep-17. The Qualification Test Report for this testing is 501-134073.

1.4. Revision Summary

Revisions to this specification include:

- Added mm wire sizes to Figure 3

2. APPLICABLE DOCUMENTS

The following documents form a part of this specification to the extent specified herein. Unless otherwise specified, the latest edition of the document applies. In the event of conflict between the requirements of this specification and the product drawing, the product drawing shall take precedence. In the event of conflict between the requirements of this specification and the referenced documents, this specification shall take precedence.

2.1. TE Documents

109-197	Test Specifications vs EIA and IEC Test Methods
114-2046	Application Specification (MAG-MATE* Series 300 Terminals)
114-2069	Application Specification (MAG-MATE* Series 187 Terminals)
501-30	Qualification Test Report (MAG-MATE* Standard Terminals)
501-134073	Qualification Test Report (MAG-MATE* Standard Terminals)

2.2. Industry Documents

EIA-364	Electrical Connector/Socket Test Procedures Including Environmental Classifications
---------	---

3. REQUIREMENTS

3.1. Design and Construction

Product shall be of the design, construction, and physical dimensions specified on the applicable product drawing.

3.2. Materials

Materials used in the construction of this product shall be as specified on the applicable product drawing.

3.3. Performance and Test Description

Product is designed to meet the electrical, mechanical and environmental performance requirements specified in Figure 1. Unless otherwise specified, all tests shall be performed at ambient environmental conditions.

3.4. Ratings

Voltage: Meets all standard industry applied winding voltage rating requirements
 Current: Meets all standard industry applied wire size current rating requirements
 Temperature: -65°C to +150°C

3.5. Test Requirements and Procedures Summary

Test Description	Requirement	Procedure
Initial examination of product.	Meets requirements of product drawing.	EIA-364-18. Visual and dimensional (C of C) inspection per product drawing.
Final examination of product.	Meets visual requirements.	EIA-364-18. Visual inspection.
Electrical		
Low Level Contact Resistance (LLCR).	See Figure 3.	EIA-364-23. Subject specimens to 100 milliamperes maximum and 20 millivolts maximum open circuit voltage. See Figure 4 and Figure 5.
Current cycling.	Termination resistance. See Figure 3, Figure 4, and Figure 5.	EIA-364-55. Subject specimens to 480 cycles of 15 minutes ON and 15 minutes OFF. Read initially and after final cycles.
Mechanical		
Insertion force.	66.7 N [15 lbf] maximum for poke-in connection. 355.9 N [80 lbf] maximum for termination into plastic housing.	EIA-364-5. Measure the force necessary to insert poke-in connection or terminate terminal into plastic housing cavity (polyester 30% glass-filled) at a maximum rate of 10 mm [.39 in] per minute.
Extraction force.	22.2 N [5 lbf] minimum for poke-in connection. 22.2 N [5 lbf] minimum for standard terminal cavity retention. 89 N [20 lbf] minimum for latch-in type terminal cavity retention.	EIA-364-5. Measure the force necessary to pull poke-in connection out of terminal or terminal out of cavity (polyester 30% glass-filled) at a maximum rate of 10 mm [.39 in] per minute.
Environmental		
Thermal shock.	See Note.	EIA-364-32, Test Condition III. Subject specimens to 25 cycles between -65 and 125°C with 30 minute dwells at temperature extremes and less than 1 minute transition time between temperatures. Measure LLCR initially and after testing.
Humidity/temperature cycling.	See Note.	EIA-364-31, Method III. Subject specimens to 10 cycles (10 days) between 25 and 65°C at 80 to 100% RH. Measure LLCR initially and after testing.
Temperature life.	See Note.	EIA-364-17, Method A. Subject specimens to 118°C for 33 days. Measure LLCR initially and after testing.



NOTE

Shall meet visual requirements, show no physical damage, and meet requirements of additional tests as specified in the product qualification and re-qualification test sequence given in Figure 2.

Figure 1

3.6. Product Qualification and Re-Qualification Test Sequence

TEST OR EXAMINATION	TEST GROUP (a)		
	1	2	3
	TEST SEQUENCE (b)		
Initial Examination of Product	1	1	1
LLCR	2,6		
Current Cycling		2	
Insertion Force (c)			2
Extraction Force (c)			3
Thermal Shock	5		
Humidity/Temperature Cycling	4		
Temperature Life	3		
Final Examination of Product	7	3	4

- i** **NOTE**
 (a) See paragraph 4.1.A.
 (b) Numbers indicate sequence in which tests are performed.
 (c) Both poke-in and cavity measurement shall be performed.

Figure 2

4. QUALITY ASSURANCE PROVISIONS

4.1. Qualification Testing

A. Sample Selection

Terminal housings and contacts shall be prepared in accordance with applicable Instruction Sheets and shall be selected at random from current production. All test groups shall each consist of 10 interconnect termination assemblies per magnet wire size. All terminals shall be terminated in accordance with Application Specification 114-2046.

B. Test Sequence

Qualification inspection shall be verified by testing specimens as specified in Figure 2.

4.2. Re-Qualification Testing

If changes that significantly affecting form, fit, or function are made to the product or manufacturing process, product assurance shall coordinate re-qualification testing consisting of all or part of the original testing sequence as determined by development/product, quality, and reliability engineering.

4.3. Acceptance

Acceptance is based on verification that the product meets the requirements of Figure 1. Failures attributed to equipment, test setup, or operator deficiencies shall not disqualify the product. If product failure occurs, corrective action shall be taken and specimens re-submitted for qualification. Testing to confirm corrective action is required before re-submittal.

4.4. Quality Conformance Inspection

The applicable quality inspection plan shall specify the sampling acceptable quality level to be used. Dimensional and functional requirements shall be in accordance with the applicable product drawing and this specification.

Wire Size (AWG [mm])†	Current Cycling				Temperature Life Humidity/Temperature Thermal Shock	
	Copper		Aluminum		Copper	Aluminum
	Resistance (milliohms max)	Test Current (amperes) See Note	Resistance (milliohms max)	Test Current (amperes) See Note	Resistance (milliohms max)	
17 [1.15]	1.4	22.0	2.9	15.0	1.1	2.2
18 [1.02]	1.8	20.0	3.6	13.5	1.4	2.8
19 [0.91]	2.2	18.0	4.4	12.0	1.7	3.4
20 [0.81]	2.7	16.0	5.5	11.0	2.1	4.2
21 [0.72]	3.5	14.0	7.0	9.5	2.7	5.4
22 [0.64]	4.3	12.5	8.6	8.5	3.3	6.6
23 [0.57]	4.6	11.0	9.1	7.5	3.5	7.0
24 [0.51]	5.7	9.5	11.4	6.5	4.4	8.8
25 [0.45]	7.2	8.0	15.9	5.5	5.5	12.2
26 [0.40]	9.1	7.5	18.2	5.0	7.0	14.0
27 [0.36]	11.4	6.0	22.8	4.0	8.8	17.6
28 [0.32]	14.4	5.0	28.9	3.5	11.1	22.2
29 [0.29]	18.0	4.5	36.0	3.0	13.8	27.7
30 [0.25]	23.0	3.5	46.0	2.3	17.7	35.4
31 [0.23]	29.1	2.0	58.2	1.3	22.4	44.7
32 [0.20]	36.0	1.5	72.0	1.0	27.6	55.4
33 [0.18]	45.7	1.0	91.5	0.7	35.2	70.4
34 [0.16]	58.0	0.5	116.0	0.35	44.4	88.9

† Metric wire sizes (mm) are provided for cross reference only. Nearest metric wire size is referred against the AWG details for user convenience.

NOTE
 Current which produces 100°C initial temperature on the magnet wire. Average reading from three thermocouples equally spaced on 12-inch lengths of magnet wire.

Figure 3 (Resistance Values)

Typical Temperature & Termination Resistance Measurement Points

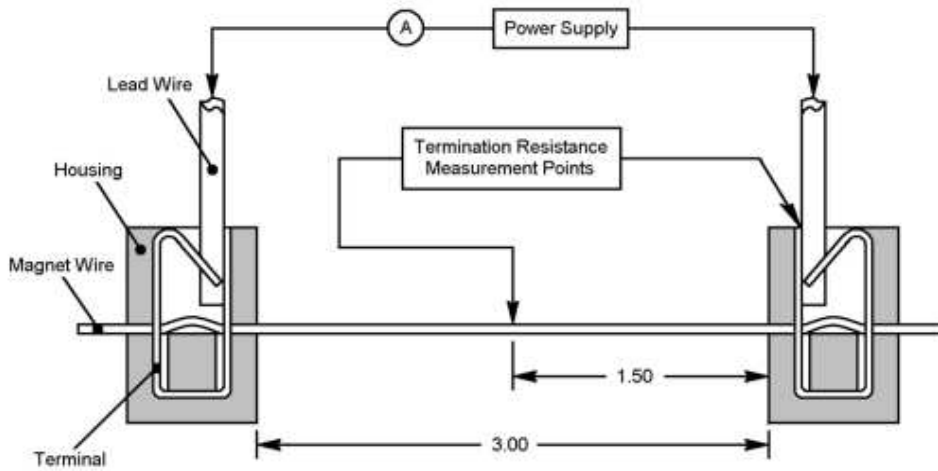

Figure 4: Standard Setup for Single Wire Terminations

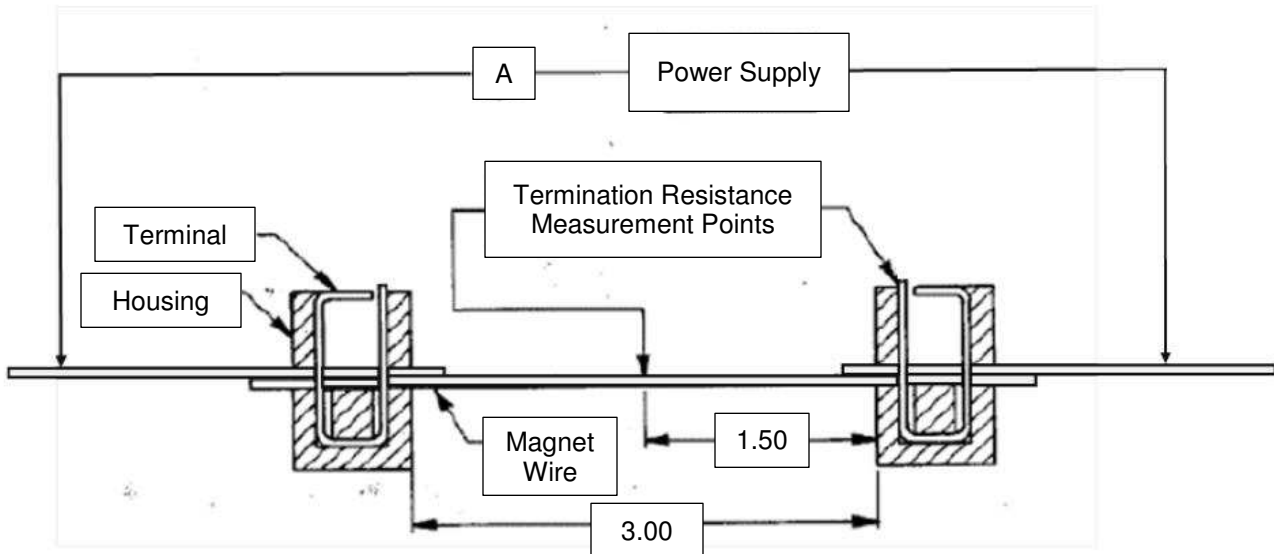

Figure 5: Alternate Setup for Double Wire Terminations

单击下面可查看定价，库存，交付和生命周期等信息

[>>TE Connectivity\(泰科\)](#)