

1 Scope:

1.1 Scope:

This specification covers general requirements for product performance and test methods of TE Connectivity 250 Series Flag FASTON\* Receptacle (hereafter called receptacle), of the part numbers specified in Para. 1.2

1.2 Scope: Applicable Terminal and Descriptions

Part Number	Descriptions	Wire size
41801	250 Series Flag FASTON Receptalce	#18-#12 AWG
41802		#20-#12 AWG
42563-1/-2		#18-#12 AWG
2232111-1		#20-#12 AWG

1.3 Wire Size

The receptacle is capable to accept to crimp on the wires of the sizes specified in the applicable customer product drawing (s).

2 Applicable Documents:

2.1 Commercial Organization Specification

The following specification forms a part of this specification to the extent specified herein ASTM B36, Alloy 260 or 274 Brass Plate, Sheet, Strip and Rolled Bar.

3 Product Performance:

3.1 Material:

Receptacle shall be fabricated of the material specified in the applicable product drawing (s).

3.2 Design Feature and Construction

Design feature and construction of receptacle shall be conforming to the applicable product drawing (s).

3.3 Electrical Performance

3.3.1 Millivolt Drop:

When tested in accordance with the test methods specified in Para. 4.3.1 the total millivolt drop of termination consisting of frictional and crimped contact in the normal atmospheric condition, shall be within the value specified in Tabel1.

mm <sup>2</sup> Wire Size (AWG)	Test Current (A)	Millivolt Drop (Mv)	Temperature Rise ( ° C)
0.51 (#20)	4	16	20
0.85 (#18)	7	28	20
1.25 (#16)	10	40	30
2.0 (#14)	15	60	30
3.0 (#12)	20	80	30

Table 1

3.3.2 Termination Resistance of Friction Contact Area:

When tested in accordance with the test method specified in Para. 4.3.1, termination resistance of frictional contact area shall not exceed 3m Ω .

3.3.3 Temperature Rising:

When tested in accordance with the test method specified in Para. 4.3.1, the value of temperature rising shall not exceed the limit specified in Table 1.

**3.4 Physical Performance:**

3.4.1 Tensile Strength:

When tested in accordance with the test method specified in Para. 4.3.2, tensile strength shall be not less than the values specified in Table 2.

mm <sup>2</sup> Wire Size (AWG)	Tensiel Strength (kg)
0.51 (#20)	4.5 (44.1N)
0.85 (#18)	5.0 (49.0N)
1.25 (#16)	12.0 (117.8N)
2.0 (#14)	22.0 (215.7N)
3.0 (#12)	40.0 (392.3N)

Table 2

3.4.2 Contact Mating Force:

When tested in accordance with the test method specified in Para. 4.3.3, contact mating force shall be conforming to the values specified in Table 3.

Contact Mating Force (Max.)	7.5kg (73.5N)
-----------------------------	---------------

Table 3

3.4.3 Contact Unmating Force:

When tested in accordance with the test method specified in Para. 4.3.4, contact unmating force shall be conforming to the values specified in Table 4.

Contact Unmating Force (Min.)	Initial	6th. Cycle
	2.5kg (24.5N)	2.0kg (19.6N)

Table 4

4 Quality Assurance Provisions:

4.1 Test Conditions:

Unless otherwise specified, all the tests shall be conducted under any combination of the following conditions.

Temperature: 20~30°C

Relative Humidity:30~80%

Atmospheric Pressure: 610~790mm Hg.

4.2 Test:

4.2.1 Test Specimens:

The test specimens to be used for the tests shall be prepared in accordance with the specified crimping method, having correct crimp height on the applicable wires, specified in table 5. For measurement of mating/unmating force, use gage tab specified in customer drawing.

4.2.2 Applicable Wires:

For crimping the samples for the tests, use the applicable wire specified in Table 5.

Wire Size		Composition of Wire Conductors		
(mm <sup>2</sup> )	(AWG)	Cross-sectional Area (mm <sup>2</sup> )	Diameter of a Conductor (mm)	Number of Conductors
0.51	(#20)	0.51	0.18	20
0.8	(#18)	0.88	0.32	11
1.25	(#16)	1.28	0.32	16
2.0	(#14)	2.09	0.32	26
3.0	(#12)	3.29	0.32	41

Table 5

4.3 Test Methods:

4.3.1 Millivolt Drop Method:

The millivolt drop and contact resistance of crimped area shall be measured by millivolt drop method. As shown in Fig.1, connect D.C. source to Z-Z and apply the test current indicated in Table 1 to the wires of applicable wire size.

The lead wire shall be longer than 920mm for heat dissipation. A set of sample specimen shall consist of a tab and a receptacle, both crimped on the wire of the same size.

After the temperature rise is stabilized, the millivolt drop Y-Z2 on the mating portion + crimped area of receptacle shall be measured by means of DC voltmeter.

This measured value includes the millivolt drop of 76mm long wire so that the millivolt drop the wire must be deducted from the measured reading. The contact resistance of mating portion shall be calculated by measuring across the mated portion X1-X2 under test current of 4 amperes.

Temperature rising value shall be measured by using the thermocouples with the test current specified in Table 1, applied on the test circuit after temperature rise has become stabilized

4.3.2 Crimp Tensile Strength:

Install sample contact which is crimped on a 152mm long wire, onto the head of tensile testing machine, and apply an axial pull-off load to the crimped wire with the speed at a rate of 25mm a minute. Crimp tensile strength of the terminal is determined when the wire is broken or is pulled off from the wire crimp.

4.3.3 Mating Force:

Install a sample on the head of tensile testing machine, and operate the head to mate the contact with the applicable tab with the speed travelling at a rate of 200mm a minute. Terminal mating force is determined when the force is measured at the completion of mating action where tab and receptacle are mated and bottomed in the correct position.

4.3.4 Unmating Force:

Install a sample on the head of tensile testing machine, and operate the head to unmate the contact with the applicable tab with the speed travelling at a rate of 200mm a minute. Unmating force is determined when the force required separate the receptacle from the mated tab contact of applicable size, is measured.

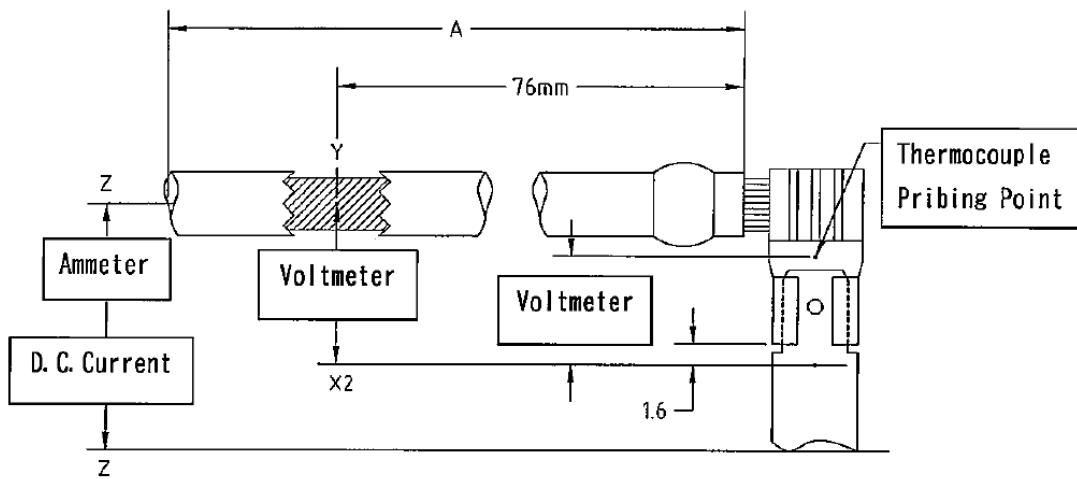

Fig 1

- A: Length of crimped wire must be not less than 920mm for sufficient effect of heat dissipation.
- X1: At the center of barrel transition between insulation support and wire crimping barrel.
- X2: At the point on the contact 1.6mm apart from front edge of the contact.
- Y: Remove insulating material at the point of probe measurement which is determined at the specified distance from the wire crimp. Apply solder to smooth contact surface preventing from variation of contact resistance value during measurement.

单击下面可查看定价，库存，交付和生命周期等信息

[>>TE Connectivity\(泰科\)](#)