

108-5151

Rev. D2

Design Objectives

(設計目標書)

Mini-Universal MATE-N-LOK Connector(UL 94V-2)

(ミニユニバーサルメイトンロックコネクタ(UL 94V-2 材))

Following first 10 pages are English version and last 9 pages are Japanese version. This top sheet is not part of the specification but explains both of English and Japanese versions are available.

このトップシートに続く最初の 10 ページは英語版で、その後の 9 ページは日本語版です。このトップシートは、規格には含まれませんが、英語、日本語両方があることを説明しています。

DESIGN OBJECTIVES

The product described in this document has not been fully tested to ensure conformance to the requirements outlined below. Therefore, AMP (Japan), Ltd makes no representation or warranty, express or implied, that the product will comply with these requirements. Further, AMP (Japan), Ltd. may change these requirements based on the results of additional testing and evaluation. Contact AMP Engineering for further details.

In case when "product specification" is referred to in this document, it should be read as "design objectives" for all times as applicable.

1. Scope:

This specification covers product performance requirements and test methods for Mini-Universal MATE-N-LOK* Connector conforming to UL 94V-2.

2. Product Descriptions:

This connector consists of contacts and single or multi-pole housing having contact positions in lattice disposition. Panel mounting housing and free hanging housing in wire-to-wire termination type, are available.

3. Material and Finish:

Contact shall be made of brass, or phosphor bronze, and tin-plated having thickness of 0.8 microns minimum, or gold plating of 0.76 microns min.

3.2 Housing:

Housing shall be made of 6/6 Nylon resin, conforming to UL 94V-2.

4. Ratings:

4.1 Voltage Rating:

300V AC or DC (conforming to Japanese Electrical Appliance and Material Control Law)
600V AC or DC (per UL and CSA Approvals)

4.2 Current Rating:

7A Max. (Refer to Fig. 1.)

4.3 Temperature Rating:

-20°C -- 105°C, (Upper limit of temperature rating must be regarded that it includes temperature rising of operated connector in addition to the effect of environmental condition.)

5. Performance Requirements:

5.1 Electrical Performance Requirements:

No.	Test Item	Para.	Specified Requirements
1	Low Level Termination Resistance	8.1	10 mΩ maximum
2	Temperature Rising	8.2	30°C maximum (Refer to Fig. 1)
3	Dielectric Strength	8.3	No abnormalities, such as corona and flashover shall be evident.
4	Insulation Resistance	8.4	1,000MΩ minimum (Initial) 100MΩ minimum (Final)

Table 1

D2	Design Objectives	RFA 1405	Y.M	24 FEB '95
D1	Revised RFA-1481			
D	Revised RFA-1030			
C	Revised per RFA-658			
B	Revised per RFA-579			
A	Revised per RFA-568			
O	Released RFA-500			
LTR	REVISION RECORD	DR	CHK	DATE

DR
CHK
APP
SHEET 1 OF 10
NAME

AMP AMP (Japan), Ltd. TOKYO, JAPAN

LOC: J A NO: 108-5151 REV: D2

Design Objectives
Mini-Universal MATE-N-LOK* Connector (UL 94V-2)

5.2 Physical Performance Requirements:

No.	Test Item	Para	Specified Requirements			
1	Vibration, Low Frequency	8.5	No electrical discontinuity greater than 10 microseconds shall occur during the test. Low level termination resistance after conditioning must not exceed 20mΩ.			
2	Physical Shock	8.6	No electrical discontinuity greater than 10 microseconds shall occur during the test. Low level termination resistance after conditioning must not exceed 20mΩ.			
3	Contact Insertion/ Extraction Force	8.8	Insertion Force:			
			Initial	450g max.		
			25th. Insertion	450g max.		
			Extraction Force:			
			Initial	70g min.		
4	Connector Insertion/ Extraction Force		No. of Pos.	Insertion Force kg (max.)	Extraction Force kg (min.)	
			1	1.5	0.1	
			2	2.7	0.2	
			3	3.3	0.3	
			4	3.9	0.4	
			6	5.5	0.6	
			9	7.0	0.9	
			12	9.0	1.2	
			15	11.0	1.5	
5	Contact Mounting Force	8.9	1.2 kg max.			
6	Contact Retention Force	8.10	4.0 kg min.			
7	Crimp Tensile Strength	8.11	Wire Size	Crimp Tensile		
			mm ²	(AWG)	kg	(lbs.)
			0.14	(#26)	2.0	(4.41)
			0.22	(#24)	3.0	(6.61)
			0.31	(#22)	5.0	(11.02)
			0.51	(#20)	6.0	(13.23)
			0.87	(#18)	7.0	(15.43)
1.27	(#16)	8.0	(17.64)			
8	Durability (Repeated Insertion and Extraction)	8.12	After insertion/extraction conditioning, sample shall meet the requirements of insertion/extraction force, and termination resistance shall be 20 mΩ max.			
9	Panel Retention Force of Housing	8.13	12.0 kg min.			
10	Housing Retention Force	8.14	4.5 kg min. 3.5 kg min. for 1-pos. connector			

Table 2

SHEET



AMP (Japan), Ltd.
TOKYO, JAPAN

2 OF 10

LOG
J

A

NO

108-5151

REV.
D2

NAME

Design Objectives

Mini-Universal MATE-N-LOK* Connector
(“L 94V-2)

5.3 Environmental Performance:

No.	Test Item	Para.	Specified Requirements
1	Thermal Shock	8.15	After thermal shock conditioning, sample must meet the requirements for dielectric strength. Termination resistance shall be not greater than 20mΩ.
2	Temperature-Humidity Cycling	8.16	After temperature-humidity cycling conditioning, sample must meet the requirements for dielectric strength and insulation resistance. Termination resistance shall be not greater than 20 mΩ. (Low Level)
3	Salt Spray	8.17	After salt spray conditioning, sample must meet the requirements for low level termination resistance of 20 mΩ max. (Low Level)
4	Arc Tracking **	8.18	After arc tracking test conditioning, sample shall not show evidence of smoking, inflammation and insulation breakdown.

Table 3

** This test shall be applied to 2 thru 4-position, hermaphroditic type connectors, only.

6. Quality Assurance Provisions:

Unless otherwise specified, all the tests shall be performed under any combination of the following test conditions.

Temperature: 15 - 35°C
 Relative Humidity: 45 - 75%
 Atmospheric Pressure: 650 - 800mmHg

SHEET			AMP (Japan), Ltd. TOKYO, JAPAN	
3 OF 10	LOC J	A	NO 108-5151	REV. D2
NAME Design Objectives Mini-Universal MATE-N-LOK* Connector (UL 94V-2)				

NUMBER 108-5151
 AMP SECURITY CLASSIFICATION
 Customer Release

6.2 Test Specimens:

6.2.1 Sample Preparation:

Test samples to be employed for the tests shall be prepared in accordance with AMP Application Specification 114-5050, Crimping Mini-Universal MATE-N-LOK* Connector Contacts, by using wires of applicable sizes specified in Table 4.

Unless otherwise specified, no sample shall be reused.

6.2.2 Applicable Wires:

Wires of applicable sizes specified in Table 4, shall be used for sample preparation.

Calculated Cross-sectional Area	Wire Size (AWG)	Strand Diameter mm	Number of Strands	Insulation Diameter mm	Applicable Specification
0.14 mm ²	(#26)	0.16	7	1.28	UL 1007
0.22 mm ²	(#24)	0.16	11	1.57	UL 1007
0.31 mm ²	(#22)	0.18	12	1.5	JCS 246
0.51 mm ²	(#20)	0.18	20	2.0	JCS 246
0.87 mm ²	(#18)	0.18	34	2.13	UL 1007
1.27 mm ²	(#16)	0.25	26	2.5	UL 1007

Table 4

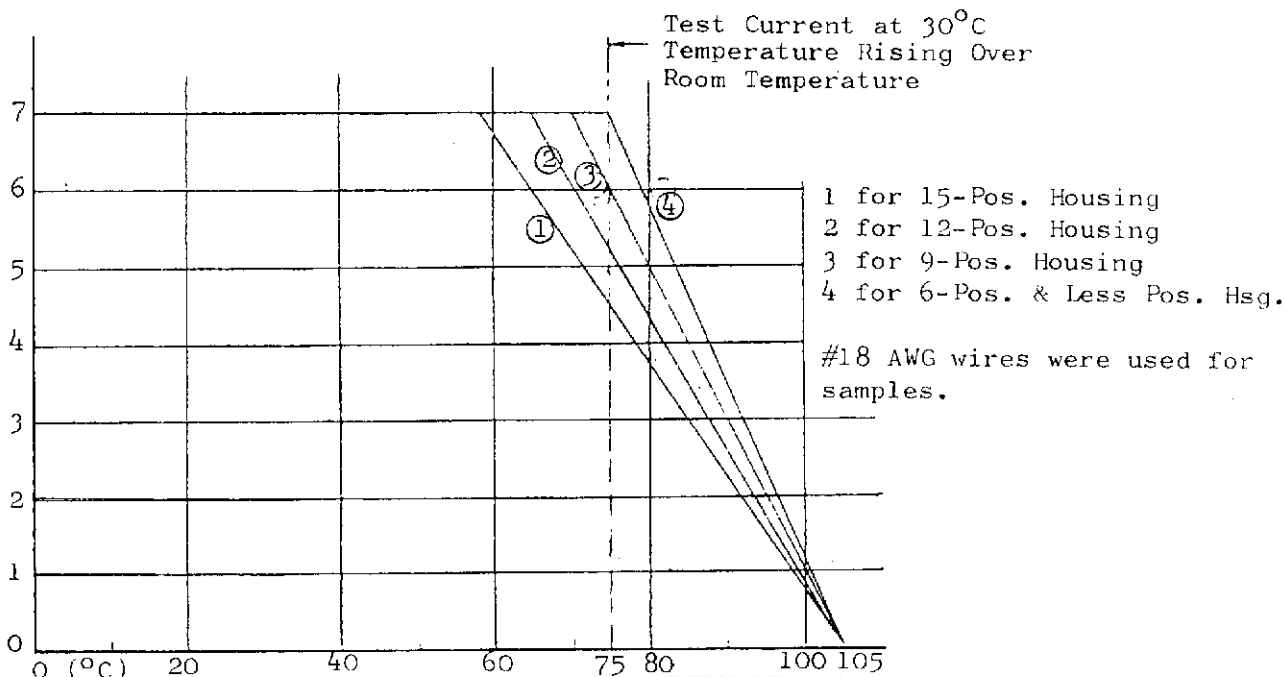

Fig. 1 Ambient Temperature Vs. Loaded Current

SHEET		AMP		AMP (Japan), Ltd. TOKYO, JAPAN	
4 OF 10	LOC J A	NO 108-5151	REV D2		
NAME Design Objectives Mini-Universal MATE-N-LOK* Connector (UL 94V-2)					

7. Test Item and Test Sequence:

Test Item	Para-graph Number	Sample Group												
		1	2	3	4	5	6	7	8	9	10	11	12	13
Confirmation of Product	—	1,3	1,3	1,4	1	1,3	1,4	1,4	1,4	1,5	1,4	1,4	1,4	1,3
Termination Resistance Low Level	8.1							2,5	2,5	2,6	2,5	2,5	2,5	
Temperature Rising	8.2					2								
Dielectric Strength	8.3						3				6	7		
Insulation Resistance	8.4						2					6		
Vibration, Low Frequency	8.5							3						
Physical Shock	8.6								3					
Contact Insertion/Extraction Force	8.7		2											
Connector Insertion/Extraction Force	8.8									3				
Contact Mounting Force	8.9				2									
Contact Retention Force	8.10						5							
Crimp Tensile Strength	8.11	2												
Durability	8.12									4				
Housing Panel Retention Force	8.13			2										
Housing Retention Force	8.14			3										
Thermal Shock	8.15										3			
Temperature-Humidity Cycling	8.16											3		
Salt Spray	8.17												3	
Arc Tracking	8.18													2

Table 5

Notes: Mechanical performance testing is not applied to Sample Groups 10, 11 and 12.

Arc tracking test is applicable to 2 thru 4-position, hermaphroditic connectors only.

SHEET			AMP (Japan), Ltd. TOKYO, JAPAN	
5 OF 10	LOG J	A	NO 108-5151	REV. D2
NAME Design Objectives				
Mini-Universal MATE-N-LOK* Connector (UL 94V-2)				

Customer Release AMP SECURITY CLASSIFICATION NUMBER 108-5151

8. Test Methods:
 8.1 Low Level Termination Resistance:

Low level termination resistance is obtained by measuring millivolt drop of the test circuit formed by mated connectors by probing across the test points between Y - Y', including wire crimps and frictional contact area. Measurement shall be done by using test current of 50mA DC max. at open circuit voltage of 50mV maximum. From the measured value, the resistance of a 150mm long wire used for termination, must be deducted before calculation. The points Y and Y' are determined at 75mm apart from end of wire crimps where insulation must be removed and soldered for obtaining stable reading of contact at probing.

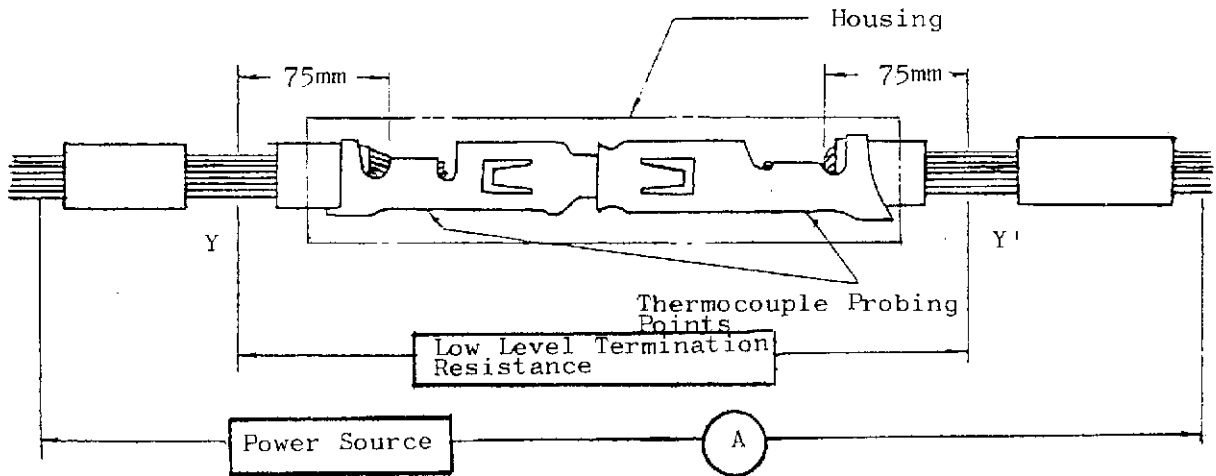

Fig. 2

8.2 Temperature Rising:

Contact-loaded, mated pair of connectors shall be tested by applying test current of specified intensity as shown in Fig. 1 to the mated contacts. Temperature rising by energized current shall be measured by using thermocouple probing at the points shown in Fig. 2. From the measured reading, room temperature must be deducted to obtain risen temperature.

8.3 Dielectric Strength:

Connector assemblies must be tested by applying test potential of 1.5KV AC increasing at a rate of 500V a second between the adjacent contacts and between the contacts and the ground. After the specified voltage is reached, the potential must be held for 1 minute.

8.4 Insulation Resistance:

Mated pair of connector assemblies must be tested by applying test potential of 500V DC between the adjacent contacts and between the contacts and the ground.

SHEET		AMP		AMP (Japan), Ltd. TOKYO, JAPAN	
6 OF 10		LOC	NO	REV	
		J A	108-5151	D 2	
NAME		Design Objectives			
		Mini-Universal MATE-N-LOK* Connector (UL 94V-2)			

8.5 Vibration, Low Frequency:

Contact-loaded and mated pair of connectors shall be vibrated on the vibration testing machine, by applying test vibration in three axial directions for 2 hours each plain, ---totally 6 hours, where the vibration varies to reciprocate in sweeping between 10-55-10 Hz. changing one cycle a minute. During the vibration, series wired contact circuit shall be monitored for electrical discontinuity greater than 10 microsecond taking place in the circuit. After testing, sample shall be visually inspected for evidence of abnormalities, and tested for low level termination resistance.

8.6 Physical Shock:

Contact-loaded and mated pair of connectors shall be tested by applying physical impact in three axial directions with six drops each plain, -- three drops in normal and three drops in reversed direction. Magnitude of impact shall be 50 G's minimum to shape a half sine wave within 10 milliseconds. After impact conditioning, inspect visually for evidence of abnormalities taking place in the sample, and measure for low level termination resistance. During impact test, test current shall be applied to the test circuit, and monitored for electrical discontinuity greater than 10 microseconds in the circuit.

8.7 Contact Insertion/Extraction Force:

Fasten socket contact on the head of tensile testing machine, and apply an axial insertion/extraction force to mate and unmate gage pin shown in Fig. 3, by operating the head to travel with the speed at a rate of 100 mm a minute. The force required to mate and unmate the gage pin shall be measured and recorded.

8.8 Connector Insertion/Extraction Force:

Contact-loaded and mating pair of connectors shall be tested by securing them on tensile testing machine in the manner that they mate and unmate as the head is operated to insert and extract in axial direction with the speed at a rate of 100,, a minute. The force required to mate and unmate the connector shall be measured and recorded.

8.9 Contact Mounting Force:

Insert contact into connector cavity, and the force required to mount the contact in correct position, shall be measured and recorded.

8.10 Contact Retention Force:

Insert a wire-crimped contact into housing cavity and confirm that the contact is locked in position. Then fasten the housing on tensile testing machine, and apply an axial pull-off load to the crimped wire by operating the head to travel with the speed at a rate of 100 mm a minute. Contact retention force is determined when the contact is dislodged from the housing cavity.

SHEET				AMP (Japan), Ltd. TOKYO, JAPAN	
7 OF 10		LOC	A	NO	108-5151
		J			REV D2
NAME Design Objectives Mini-Universal MATE-N-LOK* Connector. (UL 94V-2)					

- 8.11 Crimp Tensile Strength:
 Fasten a wire-crimped contact on the head of tensile testing machine, and apply an axial pull-off load to the end of crimped wire, by operating the head to travel with the speed at a rate of 100mm a minute. The force required to pull off the wire from the wire crimp or to break the wire, shall be measured and recorded.
- 8.12 Durability:
 Repeat insertion and extraction of connectors for 24 cycles. Then, measure for connector insertion force and extraction force respectively, and for low level termination resistance.
- 8.13 Panel Retention Force L
 Insert housing into panel cut-out mounting hole prepared with the specified dimensions, along the punch piercing direction of the panel. Then, apply an axial pull-off load from the connector mating side. The force required to dislodge housing from the cut-out hole shall be measured and recorded.
- 8.14 Housing Retention Force:
 Secure one of the mated pair of connectors which are locked with locking device, on the tensile testing machine and apply an axial pull off load to separate the housings by operating the head to travel with the speed at a rate of 100mm a minute. The force required to separate with or without damage of locking device, shall be measured and recorded.
- 8.15 Thermal Shock:
 Mated pair of connectors shall be exposed under 25 cycles of heat-cold temperature changes, each cycle consisting of the sequence as shown in Table 6. After the test duration, the samples shall be reconditioned in the room temperature for 3 hours. Then measure for dielectric strength and low level termination resistance.

Step	Temperature	Duration
1	-20 ⁺⁰ / ₋₅ °C	30 minutes
2	25 ⁺¹⁰ / ₋₅ °C	5 minutes (max.)
3	95 ⁺⁵ / ₋₀	30 minutes
4	25 ⁺¹⁰ / ₋₅	5 minutes (max.)

Table 6

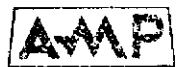
SHEET				AMP (Japan), Ltd.	
8 OF 10				TOKYO, JAPAN	
LOC	J A	NO	108-5151	REV	D2
NAME: Design Objectives					
Mini-Universal MATE-N-LOK* Connector (UL 94V-2)					

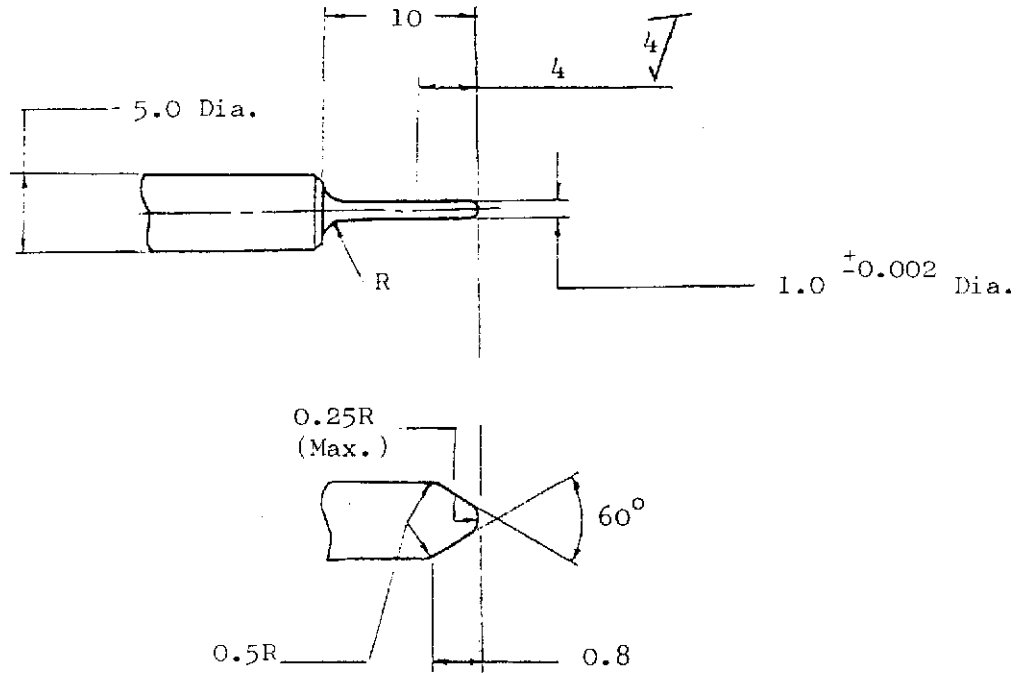

Fig. 3 Pin Gage for Measurement of Contact Insertion/Extraction Force

8.16 Temperature-Humidity Cycling:

Mated pair of connectors shall be exposed under temperature-humidity cycling in the test chamber in accordance with Test Method 106D of MIL-STD-202, where temperature changes between 25 and 65°C are controlled for 10 cycles with relative humidity of 80-98% including 10 cycles of low temperature shocks at -10°C during the test. After conditioning, recondition in the room temperature, and measure for dielectric strength, insulation resistance and termination resistance.

8.17 Salt Spray:

Mated pair of connectors shall be exposed under salt spray conditioning, in the test chamber for 48 hours where 5% salt solution spray is filled for test purposes. After duration of test conditioning, sample connector shall be taken out from the test chamber, and rinsed with tap water, and dried in the room temperature without use of powered ventilation. Low level termination resistance shall be measured and recorded.

SHEET				AMP (Japan), Ltd. TOKYO, JAPAN	
9	OF 10			LOC	NO
		J	A	108-5151	D2
NAME Design Objectives					
Mini-Universal MATE-N-LOK* Connector (UL 94V-2)					

8.18 Arc Tracking:

Arc tracking test shall be applied in accordance with IEC Publication 112. In this test, mated and energized pair of connectors are held in the manner that working axis of connector is kept vertically. From the place 30-40cm above the sample connectors, drops of specified test solutions are dripped over the connector, so that the test solution will, then, penetrate inside the connector by way of crimped wires. The detailed specification of testing is shown below.

Test Potential between the Adjacent Contacts:	300V AC, 50/60 Hz
Closed Circuit Test Current:	1 A
Test Solution:	Ammonium Chloride (NH_4Cl)
Concentration:	0.1%
Quantity of a Drop:	20^{+5}_{-0} mm ³
Number of Drops to Be Dripped:	50 Drops
Frequency Intervals:	30 \pm 5 seconds between Drops

SHEET			AMP (Japan), Ltd. TOKYO, JAPAN
10 OF 10	LOG J	NO A	108-5151
NAME Design Objectives			
Mini-Universal MATE-N-LOK* Connector (UL 94V-2)			
			REV D2



社内標準

(技術標準)

管理基準：一般顧客用

日本エー・エム・ピー株式会社

設計目標書

本製品は下記要件を満足するかが未確認です。従って、本製品がこれら要件を満足することを保証するものではありません。また、これら要件は都合により変更する場合があります。詳細は、当社技術部にお問い合わせ下さい。

本書中に「本規格は」と引用している箇所はすべて「本設計目標書は」と読み換えて適用願います。

Design Objectives

Mini-Universal MATE-N-LOK Connector(UL 94V-2)

1. 概要

本コネクタは単極及び多極よりなり、多極は格子状配列で構成されている。タイプは電線対電線接続で、パネル取付け型及び宙吊り型がある。

2. 適用範囲

本仕様書は、ミニ・ユニバーサル・メイテनロック・コネクタ (UL 94V-2 材) の全ての製品について適用される。

3. 材料及び表面処理

3.1 コンタクト

- (1) 材質 : 黄銅 燐青銅
- (2) 表面処理 : 錫めっき 0.8 ミクロン以上
金めっき 0.76 ミクロン以上

3.2 ハウジング

- (1) 材質 : 66 ナイロン樹脂
- (2) 難燃性 : UL 94V-2

4. 定格

- 4.1 電圧 : 300V AC/DC (電気用品取締法に準拠)
- 4.2 電流 : 600V AC/DC (UL, CSA 認定)
- 4.3 使用温度範囲 : 最大 7A (図1 参照)
- 4.4 使用温度範囲 : -20 °C ~ +105 °C (但し温度の上限には、負荷電流によって生ずる温度上昇分を含む)

D2	設計目標書 RFA-1905	Y.M	24 FEB 95	作成 :	分類 :	設計目標書
D1	改訂 RFA-1481		9/5/91			
D	改訂 RFA-1030	#	8-19 95			コード : 108-5151 改訂 D2
C	改訂 RFA-658	NOBLE AT	6/27 83	検閲 :		
B	改訂 RFA-579	AJMAI AT	9-12 82			
A	変更 RFA-568	AJMAI AT	7-27 82			
O	作成 RFA-500	AT	6-2 81	承認 :		
改訂	改訂記録	作成 検閲 承認	年月日	高田 6/3 81	名称 :	ミニ・ユニバーサル メイテनロック・コネクタ (UL 94V-2 材)

配布

昭和56年6月2日制定

0頁中1頁

5. 性能

5.1 電氣的性能

	項目	試験方法	規格値
1	ローレベル総合抵抗	8.1	10 mΩ 以下であること。
2	温度上昇	8.2	30 °C 以下であること (図1参照)。
3	耐電圧	8.3	コロナ放電, フラッシュオーバー等の異状がないこと。
4	絶縁抵抗	8.4	1,000 MΩ 以上 (初期) 100 MΩ 以上 (試験後)

表 1

5.2 機械的性能

	項目	試験方法	規格値																											
1	低周波振動	8.5	振動試験中 10 マイクロ秒をこえる不連続導通を生じないこと。ローレベル総合抵抗は 20 mΩ 以下。																											
2	機械的衝撃	8.6	衝撃試験によって 10 マイクロ秒をこえる不連続導通を生じないこと。ローレベル総合抵抗は 20 mΩ 以下。																											
3	コンタクト挿入引抜力	8.7	初期挿入力: 450g 以下 25回目 " " 初期引抜力: 70g 以上 25回目 " 50g																											
4	コネクタ挿入引抜力	-8.8	<table border="1"> <thead> <tr> <th>極数</th> <th>挿入力 (kg)</th> <th>引抜力 (kg)</th> </tr> </thead> <tbody> <tr> <td>1</td> <td>1.5 kg 以下</td> <td>0.1 kg 以上</td> </tr> <tr> <td>2</td> <td>2.7 kg 以下</td> <td>0.2 kg 以上</td> </tr> <tr> <td>3</td> <td>3.3 kg 以下</td> <td>0.3 kg 以上</td> </tr> <tr> <td>4</td> <td>3.9 kg 以下</td> <td>0.4 kg 以上</td> </tr> <tr> <td>6</td> <td>5.5 kg 以下</td> <td>0.6 kg 以上</td> </tr> <tr> <td>9</td> <td>7.0 kg 以下</td> <td>0.9 kg 以上</td> </tr> <tr> <td>12</td> <td>9.0 kg 以下</td> <td>1.2 kg 以上</td> </tr> <tr> <td>15</td> <td>11 kg 以下</td> <td>1.5 kg 以上</td> </tr> </tbody> </table>	極数	挿入力 (kg)	引抜力 (kg)	1	1.5 kg 以下	0.1 kg 以上	2	2.7 kg 以下	0.2 kg 以上	3	3.3 kg 以下	0.3 kg 以上	4	3.9 kg 以下	0.4 kg 以上	6	5.5 kg 以下	0.6 kg 以上	9	7.0 kg 以下	0.9 kg 以上	12	9.0 kg 以下	1.2 kg 以上	15	11 kg 以下	1.5 kg 以上
極数	挿入力 (kg)	引抜力 (kg)																												
1	1.5 kg 以下	0.1 kg 以上																												
2	2.7 kg 以下	0.2 kg 以上																												
3	3.3 kg 以下	0.3 kg 以上																												
4	3.9 kg 以下	0.4 kg 以上																												
6	5.5 kg 以下	0.6 kg 以上																												
9	7.0 kg 以下	0.9 kg 以上																												
12	9.0 kg 以下	1.2 kg 以上																												
15	11 kg 以下	1.5 kg 以上																												

表 2 (続く)

	項 目	試験方法	規 格 値		
5	コンタクト装着力	8.9	1.2 kg 以下		
6	コンタクト保持力	8.10	4 kg 以上		
7	圧着部引張強度	8.11	電線サイズ		
			mm^2	AWG	
			0.14	26	2
			0.22	24	3
			0.31	22	5
			0.51	20	6
				7	
				8	
8	耐 久 性 (コネクタ繰返し挿抜)	8.12	挿入引抜きを行った後に、コネクタ挿入引抜き力の規格値を満足し、ローレベル総合抵抗は 20 m Ω 以下。		
9	ハウジングの パネル保持力	8.13	12 kg 以上		
10	ハウジング保持力	8.14	4.5 kg 以上 但し1極は 3.5 kg 以上		

表 2 (終り)

5.3 耐環境性能

	項 目	試験方法	規 格 値
1	熱 衝 撃	8.15	試験後耐電圧の規格値を満足し、ローレベル総合抵抗は 20 m Ω 以下。
2	温湿度サイクル (耐湿性)	8.16	試験後耐電圧及び絶縁抵抗の規格値を満足し、ローレベル総合抵抗は 20 m Ω 以下。
3	塩水噴霧	8.17	ローレベル総合抵抗は 20 m Ω 以下。
4	* アークトラッキング	8.18	発煙、発火又は絶縁破壊のないこと。

表 3 * 雌雄同形型コネクタ(2~4P)のみに適用する。

6. 品質保証条件

6.1 試験条件

特に指定のない場合は、下記に示す環境条件のもとで性能試験を行うものとする。

温 度	15 ~ 35 °C
相対湿度	45 ~ 75 %
気 圧	650 ~ 800 mm Hg

6.2 試 験

(1) 試 料

性能試験に用いる試料は「ミニ・ユニバーサル・メイテンロック・コンタクトの圧着条件114-5050」に基づいて第4表に示す電線に圧着した正規の試料であること。いずれの試料も規定された順序以外の他の試験に用いてはならない。

(2) 使用電線

性能試験に用いる電線は、第4表に示す電線にて行うものとする。

計算断面積 (mm ²)	AWG	素線径 (mm)	素線数	絶縁被覆外径 (mm)	電線規格
0.14	26	0.16	7	1.28	UL 1007
0.22	24	0.16	11	1.57	UL 1007
0.31	22	0.18	12	1.5	JCS 246
0.51	20	0.18	20	2.0	JCS 246
0.87	18	0.18	34	2.13	UL 1007
1.27	16	0.25	26	2.5	UL 1007

表 4



図 1 周囲温度 - 通電電流特性

7. 試験項目及び試験手順

試験項目	該当試験 方法項目	試験グループ													
		1	2	3	4	5	6	7	8	9	10	11	12	13	
外観	#	1,3	1,3	1,4	1	1,3	1,4	1,4	1,4	1,4	1,5	1,4	1,4	1,4	1,3
ローレベル総合抵抗	8.1							2,5	2,5	2,6	2,5	2,5	2,5		
温度上昇	8.2					2									
耐電圧	8.3						3				6	7			
絶縁抵抗	8.4						2					6			
低周波振動	8.5							3							
機械的衝撃	8.6								3						
コンタクト挿入引抜力	8.7		2												
コネクタ挿入引抜力	8.8									3					
コンタクト装着力	8.9				2										
コンタクト保持力	8.10						5								
圧着部引張強度	8.11	2													
耐久性	8.12									4					
ハウジングのパネル保持力	8.13			2											
ハウジング保持力	8.14			3											
熱衝撃	8.15										3				
温湿度サイクル	8.16											3			
塩水噴霧	8.17												3		
アークトラッキング	8.18														2

表 5

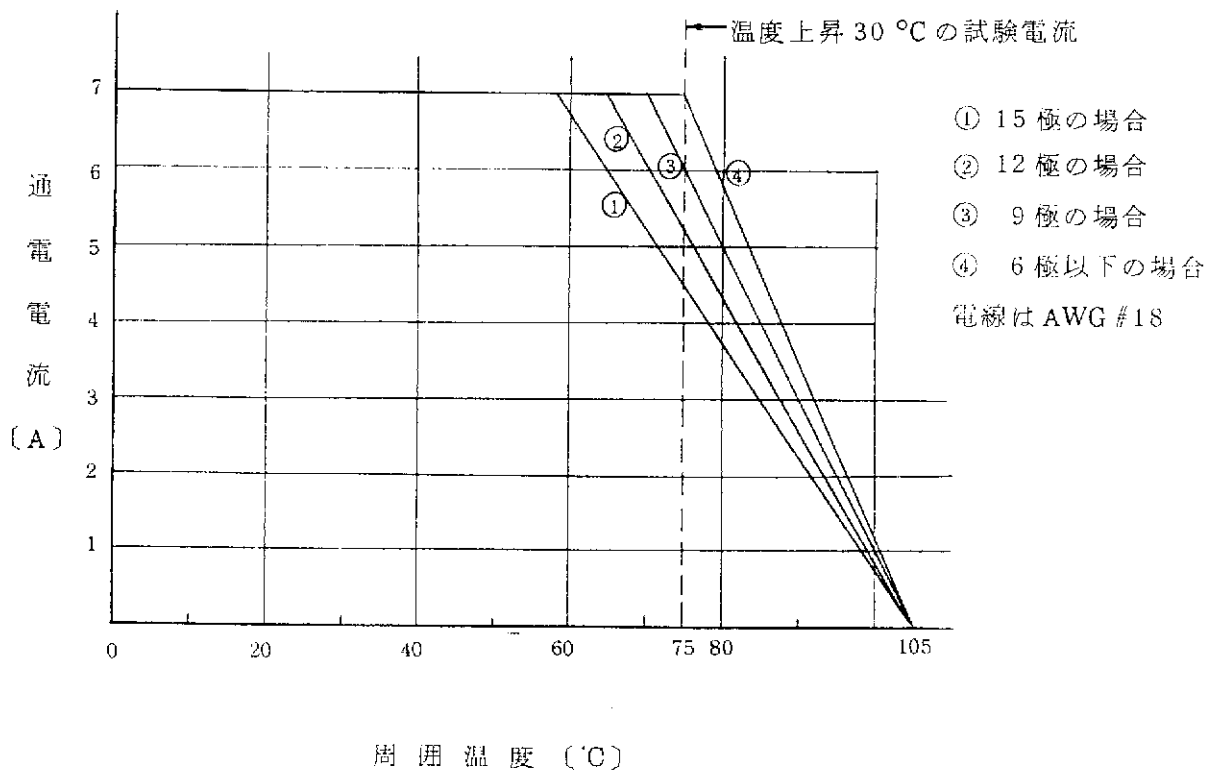
〔注〕 グループ10,11,12は機械的試験は行わない。

グループ13(アークトラッキングテスト)は雌雄同形型コネクタ(2~4P)のみに適用する。

8. 試験方法

8.1 ローレベル総合抵抗

コネクタを嵌合した状態で開放電圧 50mV DC 以下，閉路電流 50mV DC 以下で行なう。温度の上昇が安定してから，Y-Y' 間を直流電圧計で測定する。コンタクトの圧着部及び嵌合部の総合抵抗は，この測定値から 150 mm の電線の抵抗値を差引いて算出する。

Y 点は圧着部後端から測定して位置を決めるが，その場合に被覆を余分にむきとって電流密度を一様にするためブローブをあてる電線部分に半田をもる。

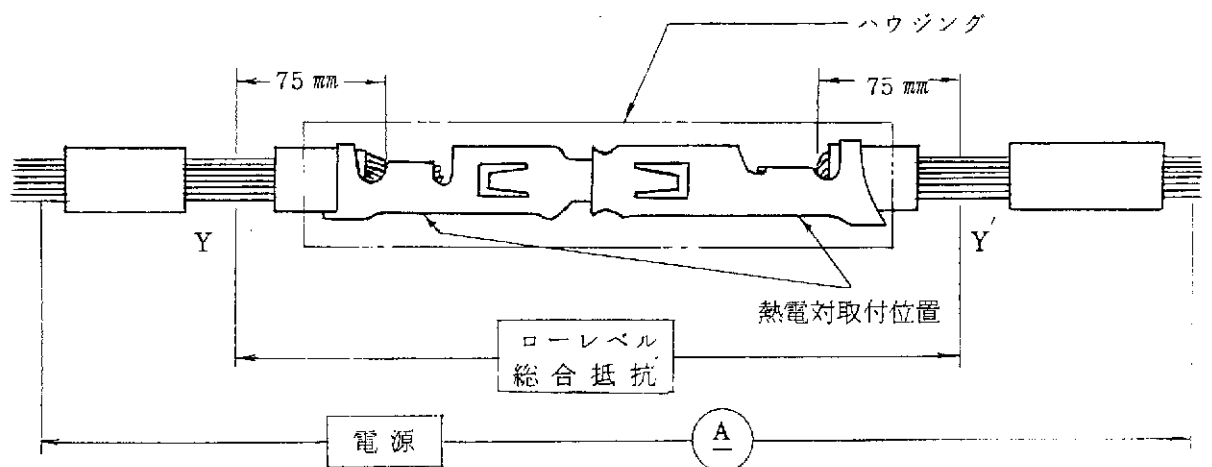

第 2 図

8.2 温度上昇

ハウジングにコンタクトを組込み，図 1 に示す試験電流を流す。図 2 に示すように，圧着部に熱電対を取り付け温度を測定し，室温を引いた値が温度上昇値である。

8.3 耐電圧

コネクタの隣接回路間に耐電圧試験機を用いて毎秒 500V の割合で電圧上昇させ，1.5 KV AC を 1 分間印加する。

8.4 絶縁抵抗

コネクタを嵌合した状態で，隣接しているコンタクト相互間およびコンタクトとアース間を測定する。なお，測定電圧は DC 500V とする。

8.5 低周波振動

10-55-10 Hz / 1分間の振動周波数，全振幅 1.52 mm をコネクタの 90 度直交する 3 軸方向に各 2 時間振動を与える。この後，外觀を観察し，ローレベル総合抵抗を測定する。また，振動試験中に不連続導通の有無を確認する。

8.6 機械的衝撃

10 ミリ秒間に 50G の半波正弦波形の衝撃をコネクタの 90 度直交する 3 軸方向正負に 3 回宛合計 18 回衝撃を行う。この後，外觀を観察し，ローレベル総合抵抗を測定する。また本試験中に不連続導通の有無を確認する。

8.7 コンタクト挿入引抜き力

ソケット・コンタクトを引張試験機に取り付けて，図 3 に規定するゲージを軸方向に 100 mm / 1 分間の速度で挿入と引抜きを行い測定する。

8.8 コネクタ挿入引抜き力

ハウジングにコンタクトを組込み，一方のハウジングを固定し，他のハウジングを 100 mm / 1 分間の速度で挿入と引抜きを行い測定する。なお，ハウジングのロック機構は取り除いておくこと。

8.9 コンタクト装着力

コンタクトをハウジングに装着するのに要する力を測定する。

8.10 コンタクト保持力

電線を圧着したコンタクトをハウジングに組込み，引張試験機にかけて電線の軸方向に 100 mm / 1 分間の速度で引張り，コンタクトがハウジングから引抜ける時の値を測定する。

8.11 圧着部引張強度

コンタクトと電線との間に垂直方向に荷重を 100 mm / 1 分間の速さで加え測定する。電線の破断又は圧着部から電線が引抜ける時の値が引張強度である。

8.12 耐久性

コネクタの挿入引抜きを 24 回繰り返す。この後コネクタ挿入引抜き力とローレベル総合抵抗を測定する。

8.13 パネル保持力

正規寸法のパネル穴にハウジングを挿入し、正規に取付けた後、挿入方向と反対側からハウジングに力を加える。パネルからハウジングが抜ける時の値を測定する。

8.14 ハウジング保持力

ロック機構が作用し正規に嵌合したコネクタの片方を固定し、他方を軸方向に100mm/1分間の速度で引張り、ロック機構の外れ又は破損して嵌合の外れた時の荷重を測定する。

8.15 熱 衝 撃

コネクタを嵌合した状態で第6表に示す試験を1サイクルとし、これを25サイクル行った後室温に3時間以上放置する。試験後耐電圧とローレベル総合抵抗を測定する。

段 階	温 度 (°C)	時 間
1	-20^{+0}_{-5}	30 分
2	25^{+10}_{-5}	最大 5 分
3	95^{+5}_{-0}	30 分
4	25^{+10}_{-5}	最大 5 分

表 6

8.16 温湿度サイクル

MIL-STD-202, 試験法 106Dにより、コネクタを嵌合した状態で相対湿度80~98%で、25~65°Cの温度変化と-10°Cの低温衝撃を10サイクル行う。測定は室内放置3時間後行う。

8.17 塩水噴霧

コネクタを嵌合した状態で5%の塩水を48時間噴霧後、塩の堆積物を水洗した後、常温で自然乾燥後、ローレベル総合抵抗を測定する。

8.18 アークトラッキング (準拠規格 IEC Pub. 112)

嵌合し電圧印加したコネクタを軸方向を垂直にした状態でコネクタ上端面から30~10mmの高さから下記に規定する水溶液を接続された電線を伝わせてコネクタ内に滴下して試験する。

隣接極間印加電圧：AC300V 50/60 Hz

短絡電流：1 A

水溶液：0.1%塩化アンモニウム(NH₄Cl)水溶液

滴下条件：滴下量 20 ± 5 mm³/滴

滴下数 50 滴

間隔 30±5 秒

分類： 設計目標書	標準の名称： ミニ・ユニバーサル メイテンロック・コネクタ (UL 94V-2材)	標準のコード： 108-5151	改訂 8 頁 D2 9 頁中
--------------	---	---------------------	-------------------

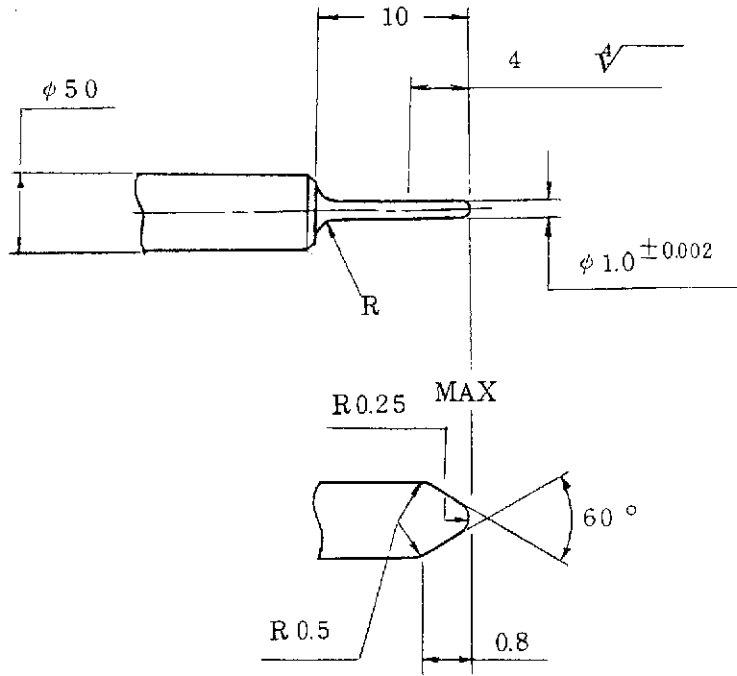

図 3 コンタクト挿入引抜き力測定用ゲージ

单击下面可查看定价，库存，交付和生命周期等信息

[>>TE Connectivity\(泰科\)](#)