

1.Scope:

1.1 Contents

This specification covers the requirements for product performance, test methods and quality assurance provisions of .070/.250 HYBRID CONNECTOR(WIRW TO WIRE)
Applicable product description and part numbers are as shown in Appendix 1.

2.Applicable Documents:

The following documents form a part of this specification to the extent specified herein. In the event of conflict between the requirements of this specification and the product drawing, the product drawing shall take precedence. In the event of conflict between the requirements of this specification and the referenced documents, this specification shall take precedence.

2.1 AMP Specifications:

- A. 109-5000 : Test Specification, General Requirements for Test Methods
- B. 114-5091, 5092 : Application Specification.
.070 Series Recep and Tab Conatact Appl. Spec. & 250 Series Recep
and Tab Contact Appli. Spec.
- C. 501-5051 : Test Report:

2.2 Commercial Standards and Specifications.

JIS C3406 Low Voltage Cables for Automobiles

3.Requirements:

3.1 Design and Construction:

Product shall be of the design, construction and physical dimensions specified on the applicable product drawing.

3.2 Materials :

A. Contact :

Tab contact : Pre-tinned brass, or Plain brass with selective gold plating over nickel underplate

Receptacle contact : Pre-tinned phosphor bronze and brass strip, or plain pfosphor bronze and brass strip with selective gold plating over nickel underplate

B. Housing :

Polybithylene : terepftthalateresin(PBT)

C. Others :

3.3 Ratings:

Temperature Rating : -30°C to 105°C

3.4 Performance and Test Descriptions:

The product shall be designed to meet the electrical, mechanical and environmental performance requirements specified in Fig.2. All tests shall be performed in the room temperature, unless otherwise specified.

3.5 Test Requirements and Procedures Summary:

Para.	Test Items	Requirements	Procedures
3.5.1	Confirmation of Product	Product shall be conforming to the requirements of applicable product drawing and Application Specification.	Visually, dimensionally and functionally inspected per applicable quality inspection plan.
Electrical Requirements			
3.5.2	Termination Resistance (Specified Current)	Test(A) Current 1 Resistance mV/A(Max.) Initial:3 Final:10	Measure initial millivolt drop of contact test circuit in mated connectors. Fig.3 AMP Spec.109-5311-2
3.5.3	Termination Resistance (Low Level)	3mΩ Max.(Initial) 10mΩ Max.(Final)	Subject mated contacts assembled in housing to closed circuit current of 10mA Max.at open circuit voltage of 20mV Max. Fig.3 AMP Spec.109-5311-1
3.5.4	Dielectric Strength	No creeping discharge nor flash-over shall occur.	1.8kVAC for 1 minute. Test between adjacent circuits of mated connectors. AMP Spec. 109-5301
3.5.5	Insulation Resistance	100MΩ Min.(Initial) 100MΩ Min.(Final)	Impressed voltage 500V DC. Test between adjacent circuits of mated connectors. AMP Spec. 109-5302 Fig.5
3.5.6	Current Leakage	3mA Max.	12V DC 60 °C Humidity 90~95%1Hr AMP Spec. 109-5312 Fig.4
3.5.7	Temperature Rising	60°C Max.under loaded specified current.	Measure temperature rising by energized current. AMP Spec. 109-5310 Method Fig.7
3.5.8	Current Cycling	10mV/A Max.(Final) 10mΩ Max.(Final) No ignition is allowed during the test.	Applied Current: Fig.7 45minutes"ON" 15minutes"OFF" 200cycles. AMP Spec.109-5308

Fig.2(To be continued)

Physical Requirements			
Para.	Test Items	Requirements	Procedures
3.5.9	Vibration (High Frequency)	No electrical discontinuity greater than 1 μ sec. shall occur. 10m Ω Max. (Final) 10mV/A Max. (Final)	Vibration Frequency: 20~200/1 min. Accelerated Velocity : 44m/s ² (4.5G) Vibration Direction : X,Y,Z Duration : 8 hours each AMP Spec.109-5202 Fig.6
3.5.10	Physical Shock	No electrical discontinuity greater than 1 μ sec. shall occur.	Vibration Frequency : 20~200/1 Min. Accelerated Velocity : 44 m/s ² (4.5G) Vibration Direction : X Duration: 8Hours AMP Spec.109-5208 Fig.8
3.5.11	Contact Mating Force	2.9~7.8N(0.3~0.8kgf) : 070 7.8~20N(0.8~2.0kgf) : 250	Operation Speed : 100mm/min. Measure the force required to mate contacts. AMP Spec.109-5206 Condition
3.5.12	Contact Unmating Force	2~7.8N(0.2~0.8kgf) : 070 7.8~20N(0.8~2.0kgf) : 250	Operation Speed : 100mm/min. Measure the force required to unmate contacts. AMP Spec.109-5206 Condition
3.5.13	Connector Mating Force	11Pos.68.6N(7kgf)Max. 13Pos.88N(9kgf)Max. 15Pos.118N(12kgf)Max.	Operation Speed : 100mm/min. Measure the force required to mate connectors. AMP Spec.109-5206 Condition
3.5.14	Connector Unmating Force	11Pos.:9.8~68.6N(1~7kgf) 13Pos.:14.7~78.5N(1.5~8kgf) 15Pos.:17.7~118N(1.8~12kgf)	Operation Speed:100mm/min. Measure the force required to unmate connectors. AMP Spec. 109-5206 Condition
3.5.15	Connector Locking Strength	98N(10kgf)Min.	Measure connector locking strength. Operation Speed:100mm/min. AMP Spec. 109-5210
3.5.16	Contact Insertion Force	14.7N(1.5kgf)Max. per contact	Measure the force required to insert contacts into housing. AMP Spec. 109-5211
3.5.17	Contact Retention Force	59N(6kgf) Min.	Apply an axial pull-off load to crimped wire. Operation Speed: 100mm/min AMP Spec. 109-5212

Fig.2(To be continued)

Para.	Test Items	Requirement				Procedures
3.5.18	Contact Retention Force (Secondary-Lock)	78.5N(8kgf) Min.				Measure contact retention force with secondary lock set in effect. Operation Speed: 100mm/min.
3.5.19	Crimp Tensile Strength	Wire Size		Crimp Tensile(min.)		Apply an axial pull-off load to crimped wire of contact secured on the tester. Operation Speed : 100mm/min. AMP Spec. 109-5205 Condition
		mm ²	(AWG)	N	(kgf)	
		0.3	(#22)	78.5	(8)	
		0.5	(#20)	88	(9)	
		0.85	(#18)	127	(13)	
		1.25	(#16)	177	(18)	
		2.0	(#14)	265	(27)	
3.0	(#12)	343	(35)			
3.5.20	Durability (Repeated Mate/Unmating)	10mΩ Max. (Final) 10mV/A Max. (Final)				Operation Speed: 100mm/min. No. of Cycles:30 Cycles. AMP Spec.109-5213
3.5.21	Resistance to "Kojiri"	10mΩ Max. (Final) 10mV/A Max. (Final)				Repeated mating/unmating by hand, 30 cycles. AMP Spec.109-5215
3.5.22	Handling Ergonomics	No abnormalities allowed in manual mating/unmating handling.				Manually operated
Environmental Requirements						
3.5.23	Thermal Shock	10mΩ Max. (Final) 10mV/A Max. (Final)				-50°C/120min.,120°C/120min. Making this a cycle, repeat 5cycles. AMP Spec. 109-5103 Condition
3.5.24	Humidity, Steady State	Termination resistance (Final) 10mV/A Max.(Final) Low Level 10mΩ Max. Current Leakage 3 mA Max.				Mated/unmated connector, 90~95% R.H.,60°C 48hours: AMP Spec. 109-5105

Fig.2(To be continued)

Para.	Test Items	Requirements	Procedures
3.5.25	Salt Spray	10mΩ Max. (Final) 10mV/A Max. (Final)	Subject Unmated connector to 5% salt concentration for 48 hours : MIL-STD-202, Method 101 AMP Spec. 109-5101 Condition
3.5.26	Industrial Gas (SO ₂)	10mΩ Max. (Final) 10mV/A Max. (Final)	SO ₂ Gas : 10 ppm, 95% R.H. normal temperature 24 hours AMP Spec. 109-5107 Condition
3.5.27	Temperature Life (Heat Aging)	10mΩ Max. (Final) 10mV/A Max. (Final)	120°C, Duration: 120 hours AMP Spec. 109-5104 Condition
3.5.28	Resistance to Cold	10mΩ Max. (Final) 10mV/A Max. (Final)	-50°C ± 5°C, 120 hours AMP Spec. 109-5108 Condition
3.5.29	Icing	10mΩ Max. (Final) 10mV/A Max. (Final)	Immerse in boiling water for 60 minutes, freeze at -30°C
3.5.30	Dust Bombardment	10mΩ Max. (Final) 10mV/A Max. (Final)	Subject JIS R5210 cement blow 1.5 kg per 10 seconds in 15 minutes intervals for 60 minutes. AMP Spec. 109-5110

Fig.2 (End)

3.6 Product Qualification Test Sequence

Test Items	Test Group (a)						
	1	2	3	4	5	6	7
	Test Sequence (c)						
Confirmation of Product	1	1	1	1	1	1	1,13,19
Termination Resistance (Specified Current)	4			4,12 15,18 22,25	3,6,9 12,16	3,6 9,12	3,6,9 12,16
Termination Resistance (Low Level)	3			3,11 14,17 21,25	2,5,8 11,15	2,5 8,11	2,8 11,15
Dielectric Strength				7			6,17
Insulation Resistance				6			5
Current Leakage				5,19	13		4,18
Temperature Rising				23			
Current Cycling				20			
Vibration (High Frequency)						7	
Physical Shock						10	
Contact Mating Force	2			2			
Contact Unmating Force	5			8			
Connector Locking Strength				27		14	
Contact Insertion Force			2				
Contact Retention Force				28		15	
Crimp Tensile Strength		2					
Resistance to "Kojiri"				10		4	7
Handling Ergonomics	6			9,26		13	20
Thermal Shock					14		
Humidity(Steady State)					10		
Salt Spray							10
Industrial SO ₂ Gas							14
Vibration And Current Cycling					4		
Temperture life (Heat Aging)					7		
Icing				16			
Dust Bombardment				13			

- (a) See Para.4.1.A.
- (b) Numbers indicate sequence in which tests are performed.
- (c) Discontinuities shall not take place in this test group, during tests.

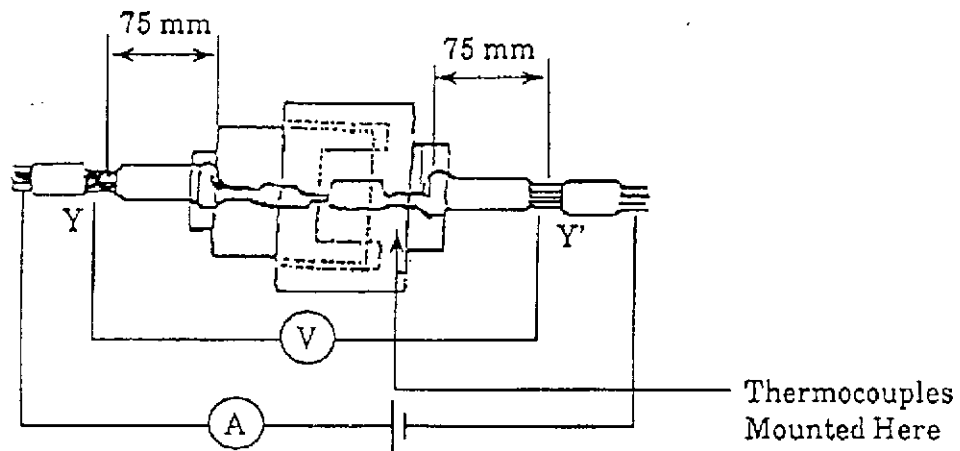

Fig.3

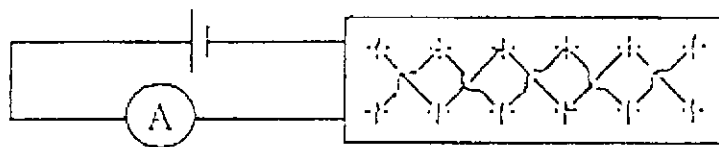

Fig.4

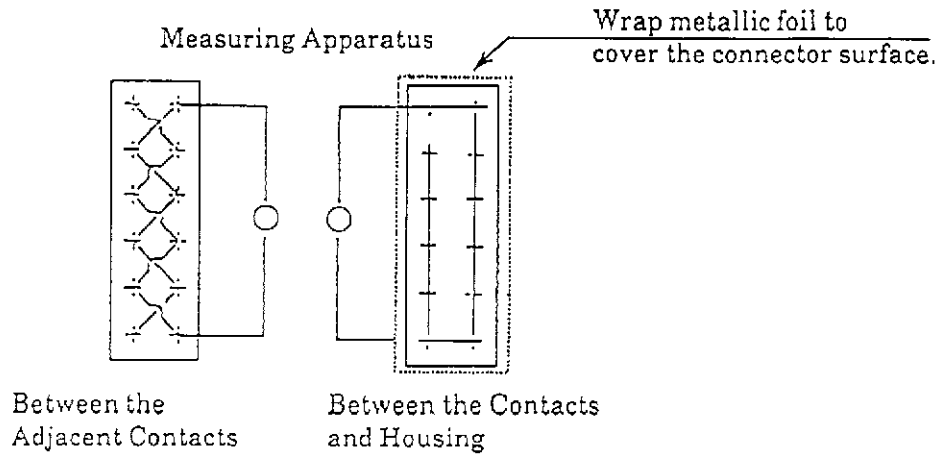

Fig.5

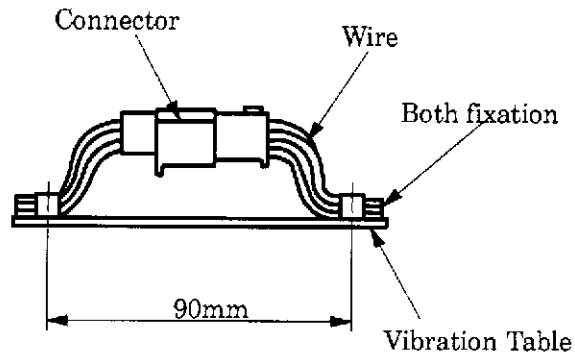

Fig.6

Wire Size(mm ²)	Allowable Current Max. (DC A)
0.2	6
0.3	8
0.8	11
0.85	15
1.25	19

Maximum Allowable Current ($I_{max.}$)

Fig.7

Number of Energized Contacts	Reduction Coefficient
1	1
2~3	0.75
4~5	0.6
6~8	0.55
9~12	0.5
13~	0.4

Note: The acceptable current carrying capacity is obtained by specified maximum efficiency obtained by the number of contacts above table.

Fig.7 Reduction Coefficient (Kd)

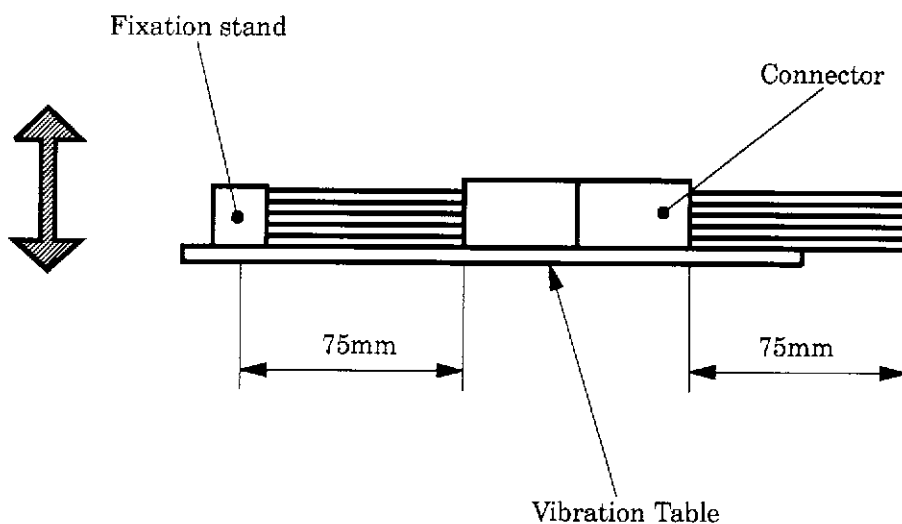

Fig.8

Quality Assurance Provisions:

1. Sample Preparation:

The test samples to be used for the tests shall be prepared by randomly selected from the current production, and terminated in accordance with 114-5091,5092, Application Specifica-

tion, Termination of .070 Series Receptacle Contacts.

No sample shall be reused, unless otherwise specified.

2. Test Conditions:

All the tests shall be performed under any combination of following test conditions, unless otherwise specified.

Temperature: 15~35°C

Relative Humidity: 45~75%

Atmospheric Pressure: 86.7~107kPa (650~800mmHg)

The applicable product descriptions and part numbers are as shown in Appendix. 1

Appendix 1

Prod. P/N	Description
173630	070 Receptacle Contact
173631	070 Receptacle Contact
173633	070 Tab Contact
173645	070 Tab Contact
170032	250 Receptacle Contact
170258	250 Receptacle Contact
170384	250 Receptacle Contact
170340	250 Tab Contact
170341	250 Tab Contact
170349	250 Tab Contact
174925	Plug Housing 11Pos.
1318478	Plug Housing 11Pos.
174926	Plug Housing 13Pos.
174927	Plug Housing 15Pos.
174940	Cap Housing 11Pos.
174941	Cap Housing 13Pos.
174942	Cap Housing 15Pos.

单击下面可查看定价，库存，交付和生命周期等信息

[>>TE Connectivity\(泰科\)](#)