

DRAWING MADE IN THIRD ANGLE PROJECTION

THIS DRAWING IS UNPUBLISHED. RELEASED FOR PUBLICATION, 19 .  
 © COPYRIGHT 19 BY AMP INCORPORATED, HARRISBURG, PA. ALL INTERNATIONAL RIGHTS RESERVED. AMP PRODUCTS MAY BE COVERED BY U.S. AND FOREIGN PATENTS AND/OR PATENTS PENDING.

LOC DIST  
 AF 50

P		F		ZONE		LTR		REVISIONS		
								DESCRIPTION	DATE	APPROVED
							B	REV & REDRAWN AF-5094	1/20/88	MSF

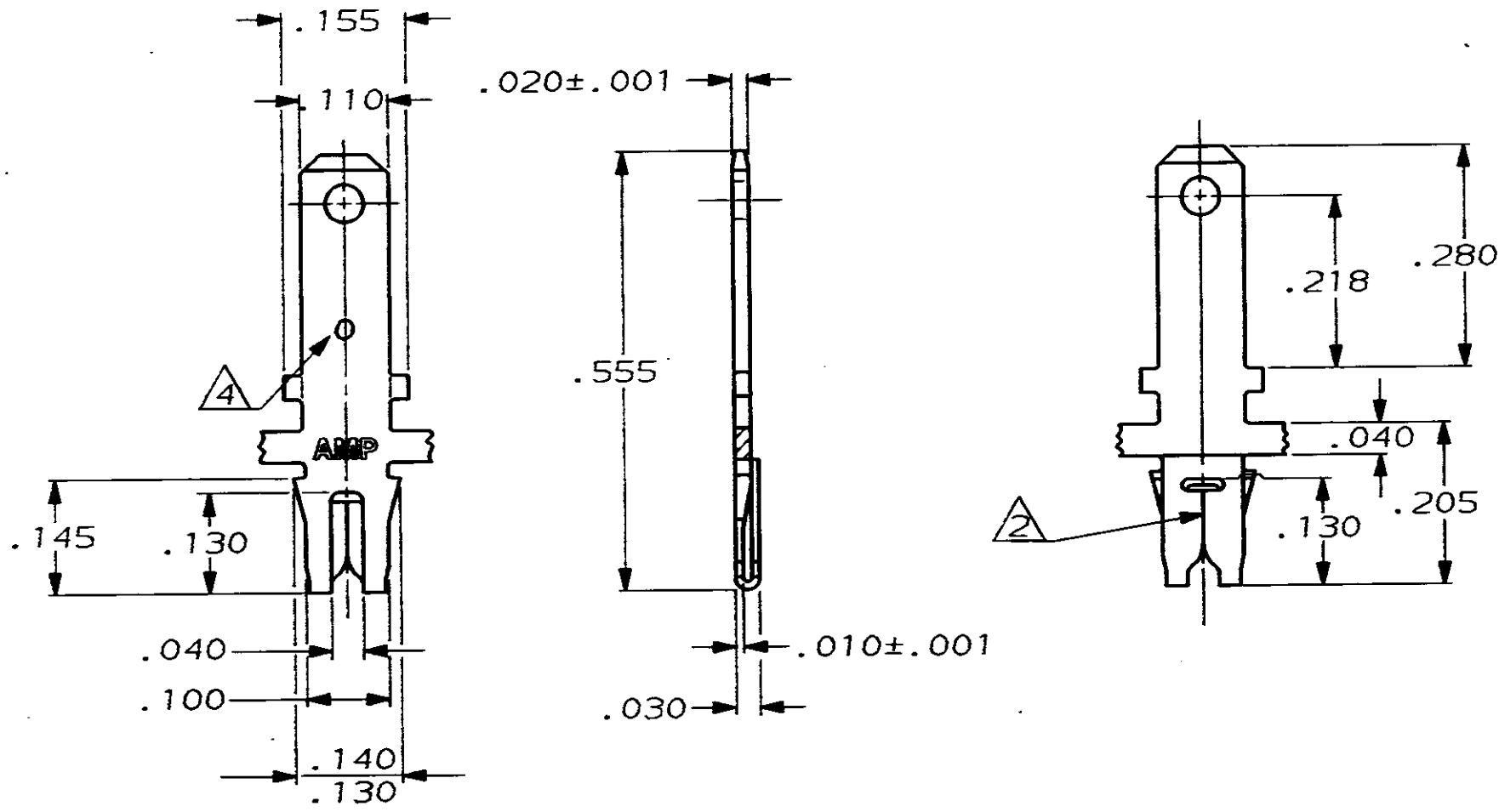

- CONTINUOUS STRIP ON REELS WITH TERMINALS LOCATED ON .220 CENTERS.
- SLOT TO ACCEPT A #34-#32 COPPER MAGNET WIRE ONLY.
- AFTER INSERTION INTO PLASTIC HOLDER, TAB PORTION MUST BE BENT OVER 45° TO 90° OR POTTED TO PREVENT PULL-OUT WHEN MATING RECEPTACLE IS DISCONNECTED.
- IDENTIFICATION NUMBER FOR MAGNET WIRE RANGE.
- MAG-MATE CAVITY SPECIFICATION.

63441-1

PART NO

UNLESS OTHERWISE SPECIFIED DIMENSIONS ARE IN INCHES  
 TOLERANCES ON:  
 2 PL DEC ± -  
 3 PL DEC ± .010  
 ANGLES ± -  
 MATERIAL #4 HARD BRASS  
 FINISH TIN

DR: MSF 1/20/88  
 CHK: G Yetton 1/22/88  
 APP'D: [Signature] 1/20/88  
 PRODUCT SPEC  
 APPLICATION SPEC 114-2099  
 WEIGHT -

<b>AMP</b>		AMP INCORPORATED Harrisburg, Pa. 17105	
NAME TAB, .110 FASTON, MAG-MATE™, MICRO			
SIZE <b>B</b>	FSCM NO 00779	DRAWING NO 63441	
SCALE 5:1	SHEET 1 OF 1		

单击下面可查看定价，库存，交付和生命周期等信息

[>>TE Connectivity\(泰科\)](#)