

THIS DRAWING IS UNPUBLISHED. RELEASED FOR PUBLICATION
 © COPYRIGHT BY TYCO ELECTRONICS CORPORATION. ALL RIGHTS RESERVED.

LOC	DIST	REVISIONS					
DF	X0	P	LTR	DESCRIPTION	DATE	DWN	APVD
		0		REV PER 0H14-0771-04	11-18-04	CT	FB

COMPONENT	MATERIAL	FINISH
HOUSING BUSHING	STAINLESS STEEL PER ASTM-A484 AND ASTM-A582, TYPE 303	PASSIVATE PER AMS-QQ-P-35
SPRING	STAINLESS STEEL	PASSIVATE PER AMS-QQ-P-35
DIELECTRIC	PTFE FLUOROCARBON PER ASTM-D-1457	N/A
CENTER CONTACT CONTACT SLEEVE	BERYLLIUM COPPER PER ASTM-B-196 OR ASTM-B-197, ALLOY C17300, CONDITION H	GOLD PLATE PER ASTM-B-488
RETAINING RING	BERYLLIUM COPPER PER ASTM-B-194, ALLOY C17200, CONDITION H	GOLD PLATE PER ASTM-B-488
RETAINING RING	BERYLLIUM COPPER PER ASTM-B-194, ALLOY C17200, CONDITION H	NICKEL PLATE QQ-N-290

ELECTRICAL	MECHANICAL	ENVIRONMENTAL
Nominal Impedance (Ohms) 50	Interface Dimensions OSM MIL-STD-348A, Fig 310.2	TEMPERATURE RATING -65°C TO +165°C
Frequency Range (GHz) DC to 18	OSP SEE CATALOG	Vibration MIL-STD-202, Method 204, Condition D.
Volt Rating (VRMS MAX) @ Sea Level 335	Mating Characteristics (OSP & OSM): Insertion (MAX Lbs) 3 Withdrawal (MIN Oz) 1	Shock MIL-STD-202, Method 213, Condition I.
VSWR 1.05 + .005 F(GHz)	Force to Engage: OSM (In-Lbs MAX) 2.0 OSP (Lbs MAX) 3.0	Thermal Shock MIL-STD-202, Method 107, Condition B.
Insertion Loss (dB MIN) .06 √F(GHz)	Force to Disengage: OSM (In-Lbs MAX) 2.0 OSP (Lbs MAX) 1.5	Moisture Resistance MIL-STD-202, Method 106
RF Leakage (dB MIN) -60 @ 2-3 GHz	Contact Retention: Axial (Lbs) 6.0 Radial (In-Oz) N/A	Corrosion - MIL-STD-202, Method 101, Condition B, 5% salt spray
Corona, 70,000 Ft (VRMS MIN) 250	Weight (Grams) TBD	
Dielectric Withstanding Voltage (VRMS MIN) @ Sea Level 1000		
Contact Resistance (Milliohms MAX) Center Contact 4.0 Outer Contact 2.0		
RF High Potential @ Sea Level (VRMS MIN @ 5 MHz) 670		
I.R.(Megohms MIN) 5000		

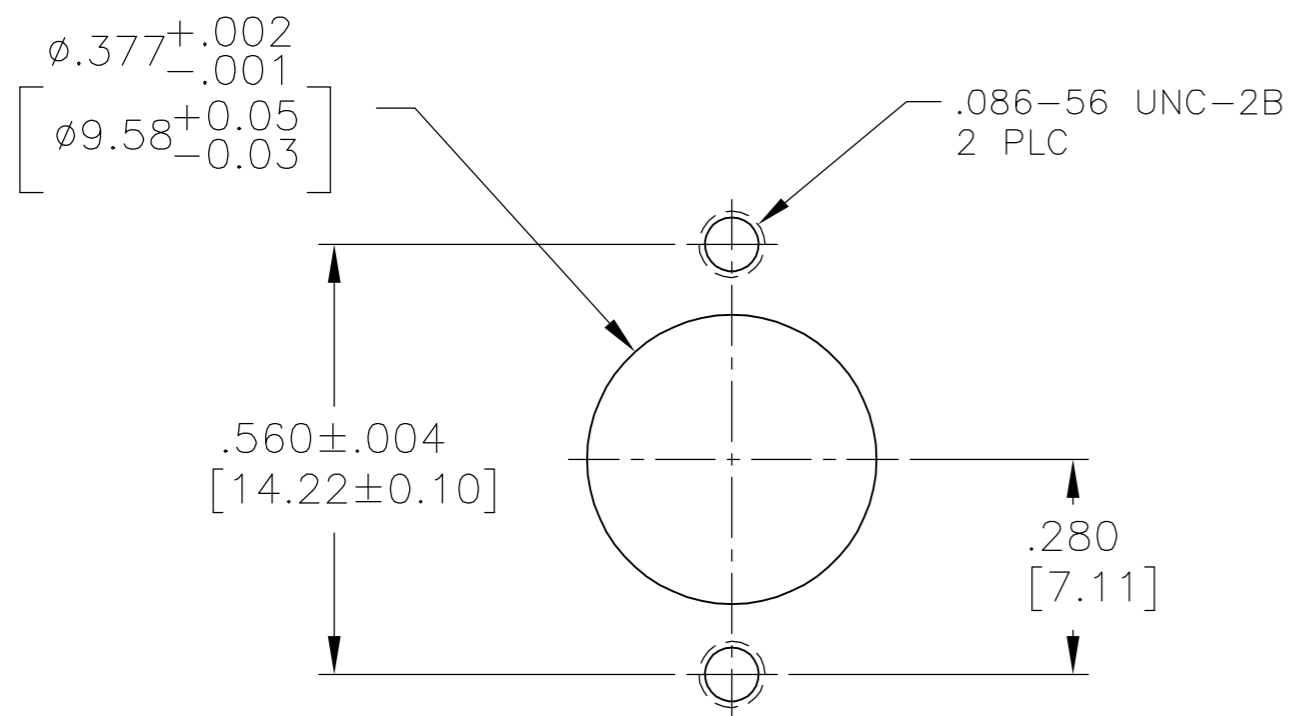
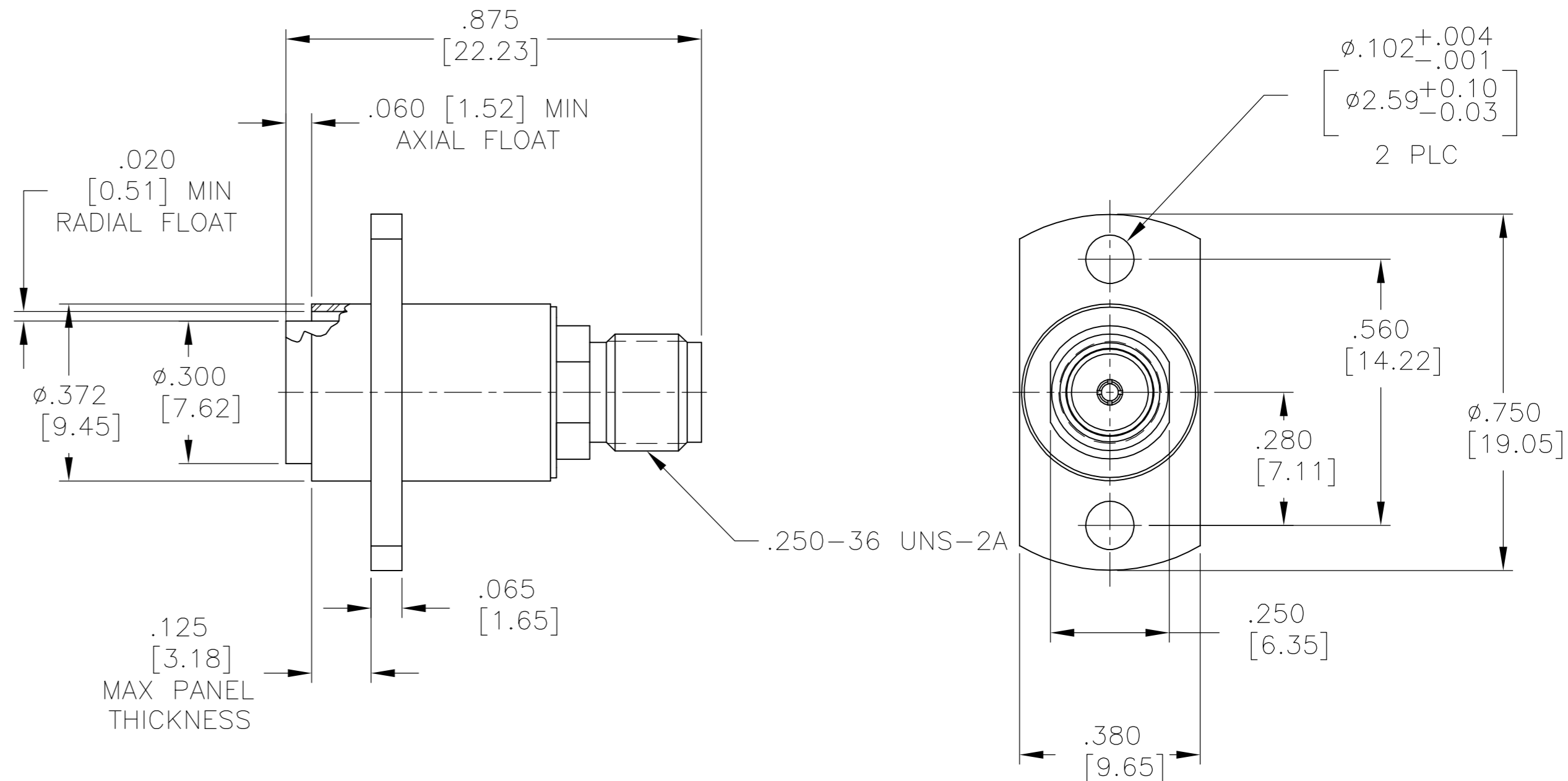

RECOMMENDED MOUNTING HOLE

1757506-1
PART NUMBER

THIS DRAWING IS A CONTROLLED DOCUMENT.		DWN C.C.THOMAS 18NOV04	Tyco Electronics Corporation Harrisburg, Pa 17105-3608	
DIMENSIONS: INCHES	TOLERANCES UNLESS OTHERWISE SPECIFIED:	CHK F.BLASICK 11-18-04	NAME F.BLASICK 11-18-04	
	0 PLC ± -	APVD F.BLASICK 11-18-04	PRODUCT SPEC	
	1 PLC ± -	APPLICATION SPEC	-	
MATERIAL	FINISH	WEIGHT	SIZE A2	CAGE CODE 00779
-	-	-	DRAWING NO C=1757506	RESTRICTED TO -
CUSTOMER DRAWING		SCALE 4:1	SHEET 1	OF 1
		REV 0		

单击下面可查看定价，库存，交付和生命周期等信息

[>>TE Connectivity\(泰科\)](#)