

LOC	DIST	REVISIONS					
—	—	P	LTR	DESCRIPTION	DATE	DWN	APVD
		A		REDRAWN PER ECR-10-019776	22OCT10	HMR	PD

- 1 REVERSE REEL FOR ARTOS MACHINE
- 2 CONTINUOUS STRIP, ON REELS
- 3 WIRE SIZE: #20-16 AWG

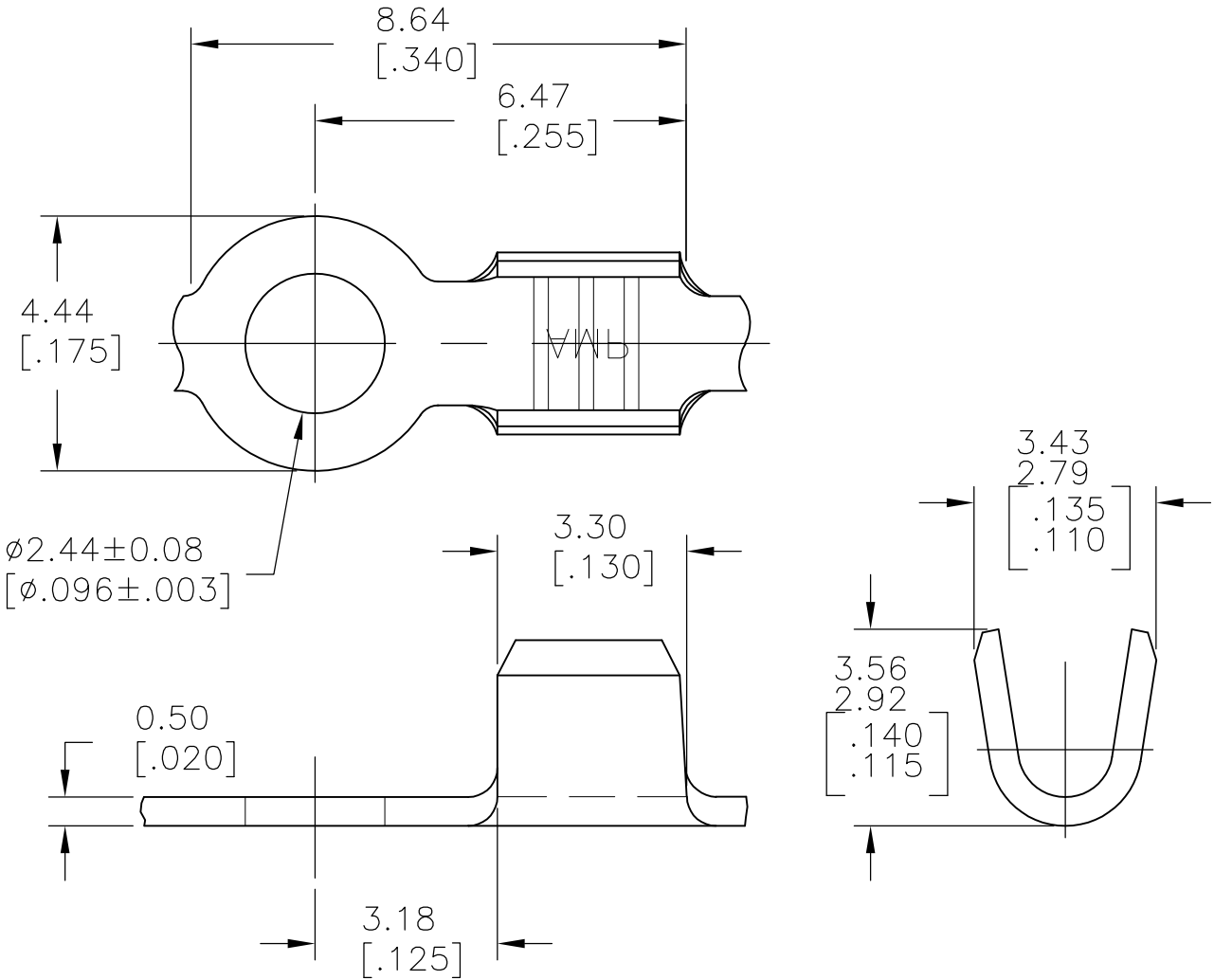

THIS DRAWING IS UNPUBLISHED.

ALL INTERNATIONAL RIGHTS RESERVED.

COPYRIGHT BY TYCO ELECTRONICS CORPORATION.

40816
PART NUMBER

DIMENSIONS: mm [INCHES]	DWN RAGHAVENDRA 22OCT10	MATERIAL BRASS	FINISH TIN
	CHK DESANTIS PETER 22OCT10	Tyco Electronics Corporation Harrisburg, PA 17105-3608	
TOLERANCES UNLESS OTHERWISE SPECIFIED:	APVD DESANTIS PETER 22OCT10	NAME RING	
	PRODUCT SPEC —	SIZE A4	CAGE CODE 00779
0 PLC ± -	APPLICATION SPEC —	DRAWING NO C-40816	RESTRICTED TO —
1 PLC ± -	WEIGHT —	SCALE 8:1	
2 PLC ± -		SHEET 1 OF 1	
3 PLC ± .015		REV A	
4 PLC ± -		CUSTOMER DRAWING	
ANGLES ± 1'			

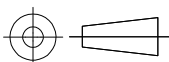

单击下面可查看定价，库存，交付和生命周期等信息

[>>TE Connectivity\(泰科\)](#)