

REVISIONS					
P	LTR	DESCRIPTION	DATE	DWN	APVD
	G	PER PCN E-20-018081	10MAR2021	SCK	

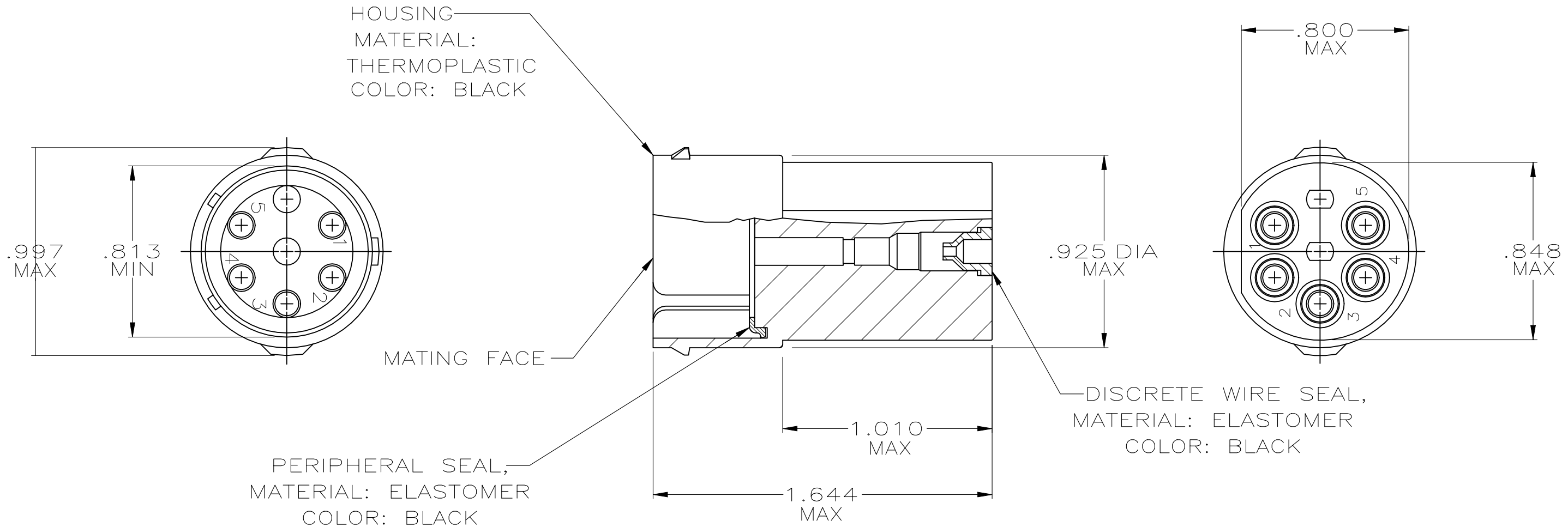

1. WIRE INSULATION SEALING RANGE: .070—.130 DIA.
2. THIN MEMBRANE PERMISSABLE ON SMALL DIAMETER OF WIRE SEALS.
3. ROTATION OF CAVITY CIRCUIT KEY FROM PART TO PART IS PERMISSIBLE.

NO	207848-2
YES	207848-1
SEALS	PART NO

THIS DRAWING IS A CONTROLLED DOCUMENT.		DWN	A.STAUB BG	8/2/90	<b>STE</b> TE Connectivity		
DIMENSIONS: INCHES		CHK	-	-			
TOLERANCES UNLESS OTHERWISE SPECIFIED:		APVD	-	-	RECEPTACLE, 5 POSITION, STD ECONOSEAL CONNECTOR		
0 PLC ± -		PRODUCT SPEC	-	-	SIZE		
1 PLC ± -		APPLICATION SPEC	-	-	CAGE CODE	DRAWING NO	RESTRICTED TO
2 PLC ± -					A3	00779	C-207848
3 PLC ± -					SCALE		
4 PLC ± -					SHEET		
ANGLES ± -					1 OF 1		
FINISH					REV		
MATERIAL SEE CALLOUT					G		
		WEIGHT	0.000000	CUSTOMER DRAWING			

单击下面可查看定价，库存，交付和生命周期等信息

[>>TE Connectivity\(泰科\)](#)