

THIS DRAWING IS UNPUBLISHED. RELEASED FOR PUBLICATION  
 © COPYRIGHT - By - ALL RIGHTS RESERVED.

REVISIONS				
P	LTR	DESCRIPTION	DATE	APVD
	D2	REVISED PER ECO-16-012744	03OCT2016	NK DR

<b>AMP</b> WIRE RANGE	Listed FILE E13288	LR7189 Certified	MILITARY P/N AND CLASS
3/0 AWG SOLID OR STRANDED	3/0 AWG STRANDED	3/0 AWG SOLID OR STRANDED	MS 20659-155 CLASS 2

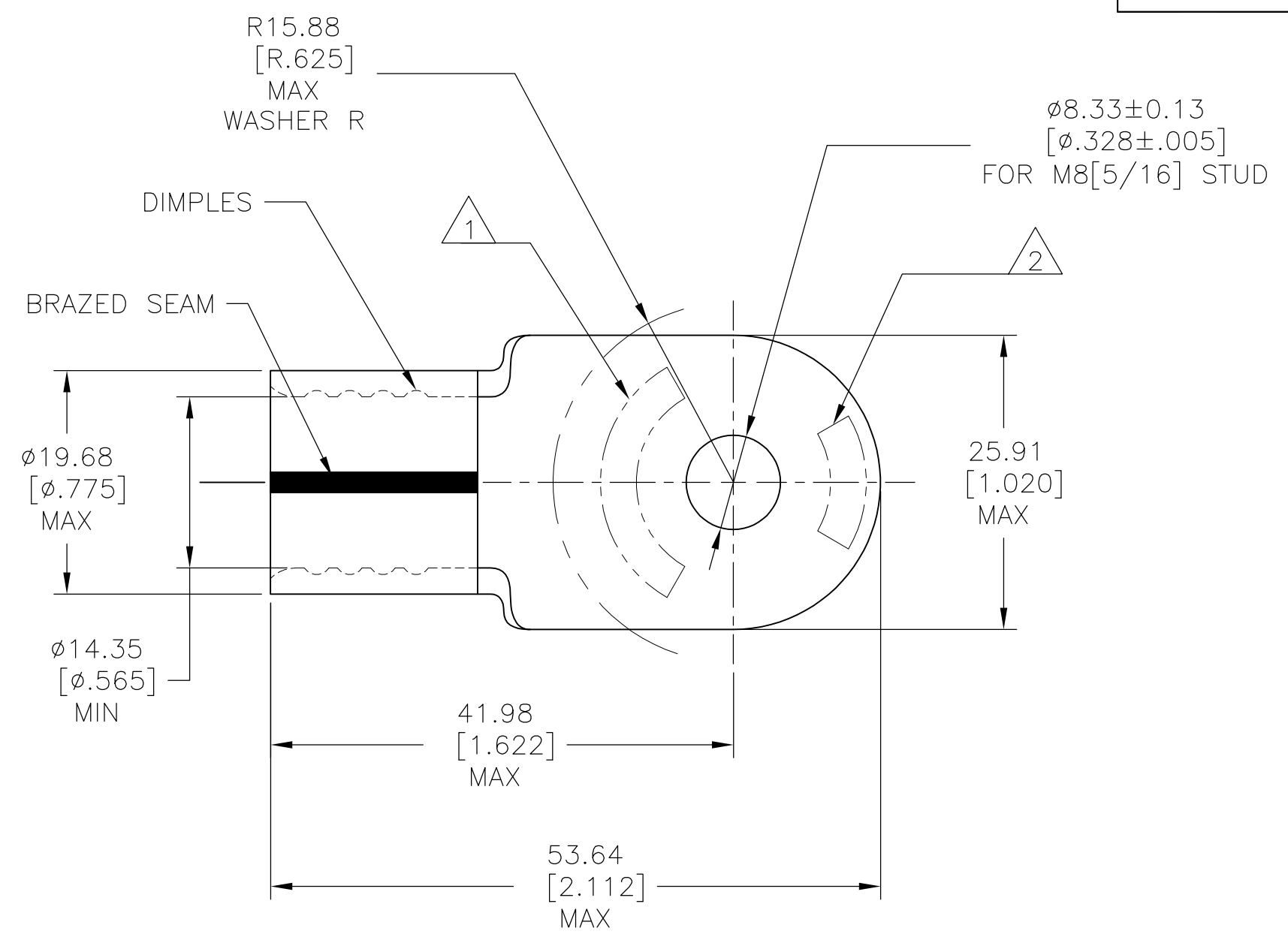

- 1 STAMP AMP 3/0W\* APPROX AS SHOWN.
- 2 STAMP 150 APPROX AS SHOWN.
- 3 MATERIAL THK:  $2.31 \pm 0.08$  [.091 ± .003].
- 4 MATERIAL: COPPER PER ASTM B-152, ANNEALED.
- 5 FINISH: 0.00254 [.000100] MIN THK TIN PLATE PER ASTM B-545.
- 6 NOTE DELETED.
- 7 NOTE DELETED.

321874  
PART NO.

AMP INCORPORATED  
CUSTOMER SERVICE SYSTEMS

FOR ADDITIONAL PRODUCT INFORMATION OR COPIES OF DRAWINGS AND TECHNICAL DOCUMENTS	PRODUCT INFORMATION CENTER 1-800-522-6752	MAX RECOMMENDED OPERATING TEMPERATURE: 170°C [338°F]
FOR APPLICATION TOOLING INFORMATION	TOOLING ASSISTANCE CENTER 1-800-722-1111	VOLTAGE RATING: N/A
FOR ORDER ENTRY	1-800-526-5142	WIRE CROSS SECTIONAL AREA RANGE: 76.3-96.3mm <sup>2</sup> [150,000-190,000] CIR MILS SOLID OR STRANDED

THIS DRAWING IS A CONTROLLED DOCUMENT.

DIMENSIONS: mm [INCHES]	TOLERANCES UNLESS OTHERWISE SPECIFIED:
	0 PLC ± -
	1 PLC ± -
	2 PLC ± 0.20 [.008]
	3 PLC ± -
	4 PLC ± -
	ANGLES ± -
MATERIAL	FINISH
4	5

DWN	DK SCHRUM	11/27/91
CHK	RD HEIM	1/10/92
APVD	CR RHOADS	1/10/92
PRODUCT SPEC		
APPLICATION SPEC		
WEIGHT		
CUSTOMER DRAWING		

TE Connectivity			
NAME TERMINAL, RING TONGUE, SOLISTRAND			
SIZE	CAGE CODE	DRAWING NO	RESTRICTED TO
A3	00779	C-321874	-
SCALE 2:1		SHEET 1 OF 2	REV D2

THIS DRAWING IS UNPUBLISHED. RELEASED FOR PUBLICATION  
 © COPYRIGHT - By - ALL RIGHTS RESERVED.

REVISIONS				
P	LTR	DESCRIPTION	DATE	APVD
-	-	SEE SHEET 1	-	-

**AMP**  
WIRE RANGE

---

3/0 AWG  
SOLID OR STRANDED

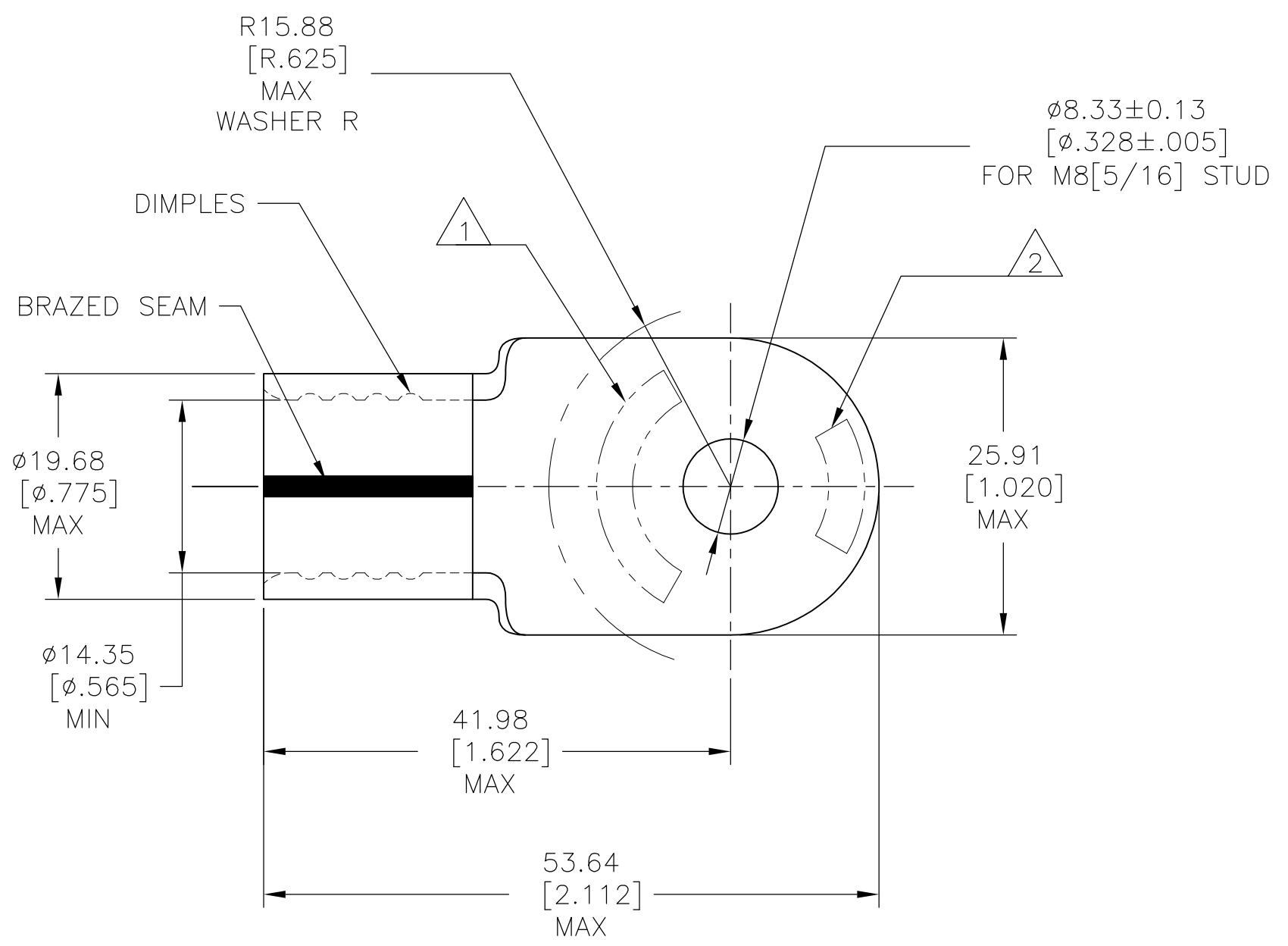

- 1 STAMP AMP 3/0W\* APPROX AS SHOWN.
- 2 STAMP 150 APPROX AS SHOWN.
- 3 MATERIAL THK: 2.31 ± 0.08 [.091 ± .003].
- 4 MATERIAL: COPPER PER ASTM B-152, ANNEALED.
- 5 FINISH: 0.00762 [.000300] MIN THK NICKEL PLATE PER SAE AMS QQ-N-290.
- 6 NOTE DELETED.
- 7 NOTE DELETED.

321874-2  
PART NO.

<b>AMP INCORPORATED CUSTOMER SERVICE SYSTEMS</b>		
FOR ADDITIONAL PRODUCT INFORMATION OR COPIES OF DRAWINGS AND TECHNICAL DOCUMENTS	PRODUCT INFORMATION CENTER 1-800-522-6752	MAX RECOMMENDED OPERATING TEMPERATURE: 343°C [649°F]
FOR APPLICATION TOOLING INFORMATION	TOOLING ASSISTANCE CENTER 1-800-722-1111	VOLTAGE RATING: N/A
FOR ORDER ENTRY	1-800-526-5142	WIRE CROSS SECTIONAL AREA RANGE: 76.3-96.3mm <sup>2</sup> [150,000-190,000] CIR MILS SOLID OR STRANDED

THIS DRAWING IS A CONTROLLED DOCUMENT.	
DIMENSIONS: mm [INCHES]	TOLERANCES UNLESS OTHERWISE SPECIFIED:
	0 PLC ± -
	1 PLC ± -
	2 PLC ± 0.20 [.008]
	3 PLC ± -
	4 PLC ± -
	ANGLES ± -
MATERIAL	FINISH
4	5

DWN DK SCHRUM 11/27/91	<b>STE</b> TE Connectivity			
CHK RD HEIM 1/10/92				
APVD CR RHOADS 1/10/92	NAME TERMINAL, RING TONGUE, SOLISTRAND			
PRODUCT SPEC	SIZE	CAGE CODE	DRAWING NO	RESTRICTED TO
APPLICATION SPEC	A3	00779	C-321874	-
WEIGHT	CUSTOMER DRAWING			SCALE 2:1
	SHEET 2 OF 2		REV D2	

单击下面可查看定价，库存，交付和生命周期等信息

[>>TE Connectivity\(泰科\)](#)