

THIS DRAWING IS UNPUBLISHED. RELEASED FOR PUBLICATION  
 © COPYRIGHT - By - ALL RIGHTS RESERVED.

LOC	DIST	REVISIONS					
GP	00	P	LTR	DESCRIPTION	DATE	DWN	APVD
		P		REVISED PER ECO-11-004835	11MAR11	RK	HMR

OPENING FOR CABLE  
 (SEE DASH NO. FOR DIA.)

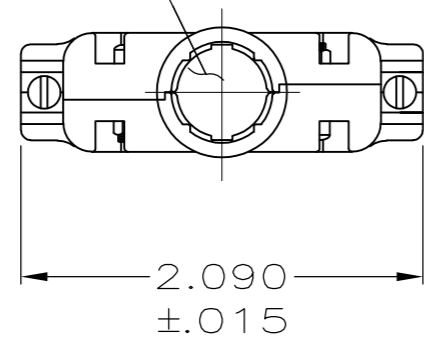

- PARTS PACKAGED UNASSEMBLED, AS A UNIT KIT.
- ZINC PLATED .000200-.000400 THICK, CLEAR CHROMATE COATING.

SIZE IDENTIFICATION LETTER  
 MOLDED IN APPROXIMATE AREA  
 SHOWN, SEE TABLE

#4-40 HEX NUT  
 (QTY. 2)  
 MATL: CARBON STEEL  
 FINISH:  $\triangle 2$

#4-40 FIL HD SCREW  
 (QTY. 2)  
 MATL: STEEL  
 FINISH:  $\triangle 2$

AMP LOGO

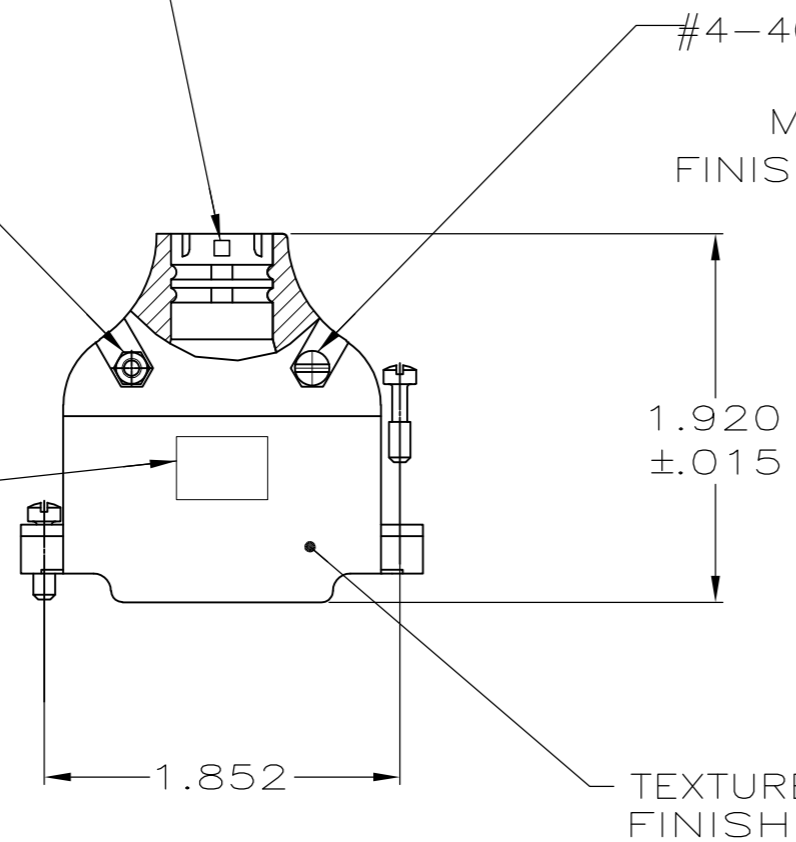

TEXTURED FINISH

CABLE CLAMP HALF  
 (QTY. 2)  
 MATL: ZINC ALLOY  
 FINISH: NICKEL OVER COPPER

.680  
 $\pm .015$

#4-40 MOUNTING SCREW  
 (QTY. 2)  
 MATL: CARBON STEEL  
 FINISH:  $\triangle 2$

.620  
 $\pm .015$

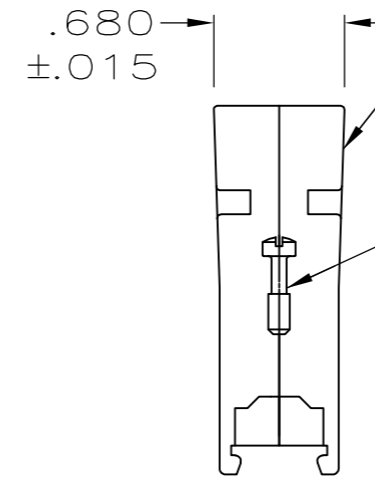

D	.280	5745173-5
G	.350	5745173-4
K	.430	5745173-3
M	.480	5745173-2
P	.530	5745173-1
NECK SIZE IDENT	MAX CABLE DIA	PART NUMBER

THIS DRAWING IS A CONTROLLED DOCUMENT.		DWN	12AUG05		TE Connectivity																	
DIMENSIONS: INCHES		CHK	12AUG05																			
TOLERANCES UNLESS OTHERWISE SPECIFIED:		APVD	12AUG05																			
<table border="1"> <tr><td>0 PLC</td><td>±</td><td>-</td></tr> <tr><td>1 PLC</td><td>±</td><td>-</td></tr> <tr><td>2 PLC</td><td>±</td><td>-</td></tr> <tr><td>3 PLC</td><td>±</td><td>.005</td></tr> <tr><td>4 PLC</td><td>±</td><td>-</td></tr> <tr><td>ANGLES</td><td>±</td><td>-</td></tr> </table>		0 PLC	±			-	1 PLC	±	-	2 PLC	±	-	3 PLC	±	.005	4 PLC	±	-	ANGLES	±	-	NAME
0 PLC	±	-																				
1 PLC	±	-																				
2 PLC	±	-																				
3 PLC	±	.005																				
4 PLC	±	-																				
ANGLES	±	-																				
MATERIAL SEE CALLOUTS		FINISH	SEE CALLOUTS	SIZE	CAGE CODE	DRAWING NO	RESTRICTED TO															
SEE CALLOUTS		WEIGHT	-	A2	00779	C=5745173	-															
CUSTOMER DRAWING				SCALE	1:1	SHEET	1 of 1															
				REV	P																	

单击下面可查看定价，库存，交付和生命周期等信息

[>>TE Connectivity\(泰科\)](#)