

LOC	DIST	REVISIONS			
REV	LTN	DESCRIPTION	DATE	DWN	APVD
A		RELEASED	28OCT2006	LAM	JW
B		ECO-07-001858	01FEB2007	LAM	JW
C		ECR-08-019486	05AUG2008	A. L.	S. Y.

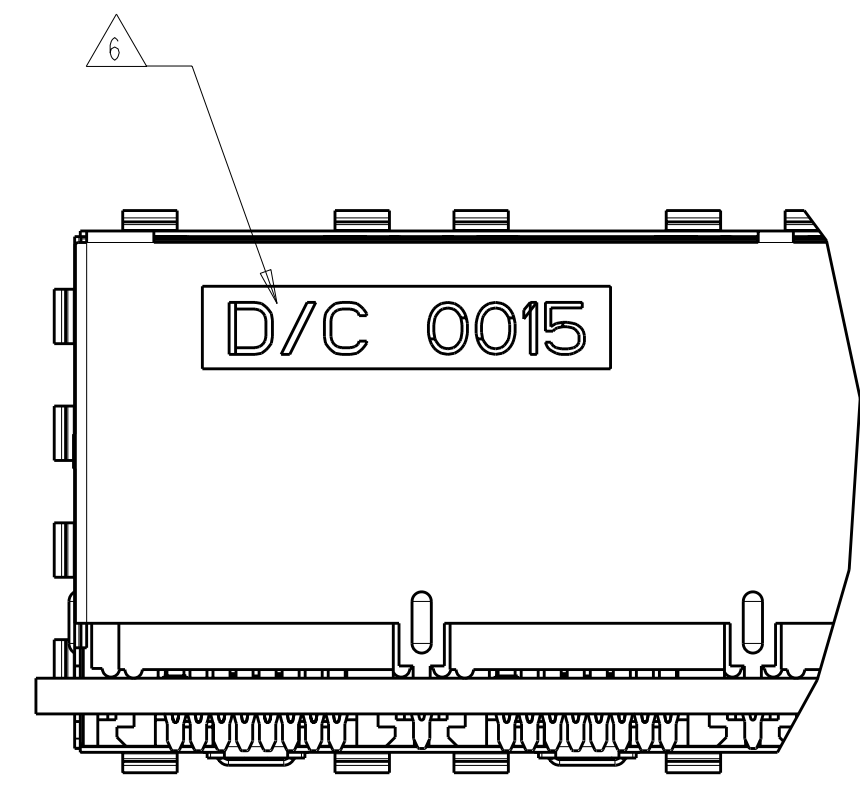

ATCA PANEL AND PRINTED CIRCUIT BOARD ASSEMBLY LAYOUT

- MATERIAL:
 HOUSING: PBT POLYESTER, BLACK, UL 94V-0
 TERMINALS: 0.33 THICK PHOSPHOR BRONZE PLATED WITH 1.27µm MINIMUM THICK HARD GOLD IN LOCALIZED AREA AND 2.0µm MINIMUM THICK MATTE TIN IN COMPLIANT PIN TERMINAL AREA OVER 1.27µm MINIMUM THICK NICKEL UNDERPLATE
 SHIELD: 0.25 THICK COPPER ALLOY PLATED WITH 2.03µm MINIMUM TIN OVER 1.27 µm MINIMUM NICKEL
 GROUND CLIP: 0.25 THICK COPPER ALLOY PRE-PLATED WITH 2.03µm MINIMUM MATTE TIN OVER 1.27µm MINIMUM NICKEL
 - JACK CAVITY CONFORMS TO FCC RULES AND REGULATIONS, PART 68 SUBPART F.
- ③ MAXIMUM PIN LENGTH 3.40 FROM TOP SURFACE OF PC BOARD
 - ④ FINISHED PLATED THROUGH HOLE DIAMETER - ANNULAR RING DIAMETER 1.3 TO 1.5
 - ⑤ DATUMS AND BASIC DIMENSIONS ESTABLISHED BY CUSTOMER
 - ⑥ DATE CODE LOCATED ON REAR OF PART APPROXIMATELY AS SHOWN
 - ⚠ CONTACTS ARE NOT INTENDED TO BE ALIGNED WITH EACH OTHER

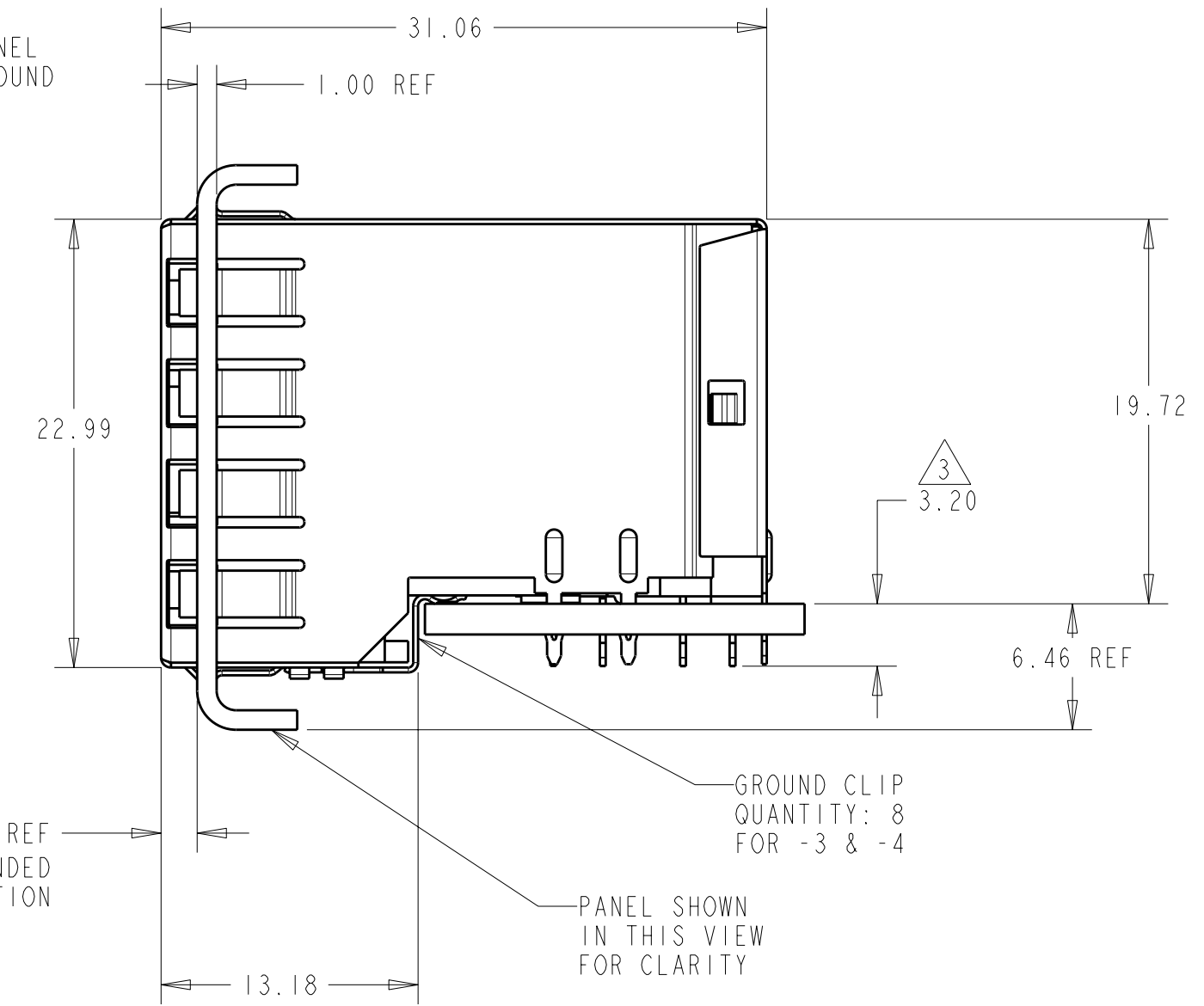
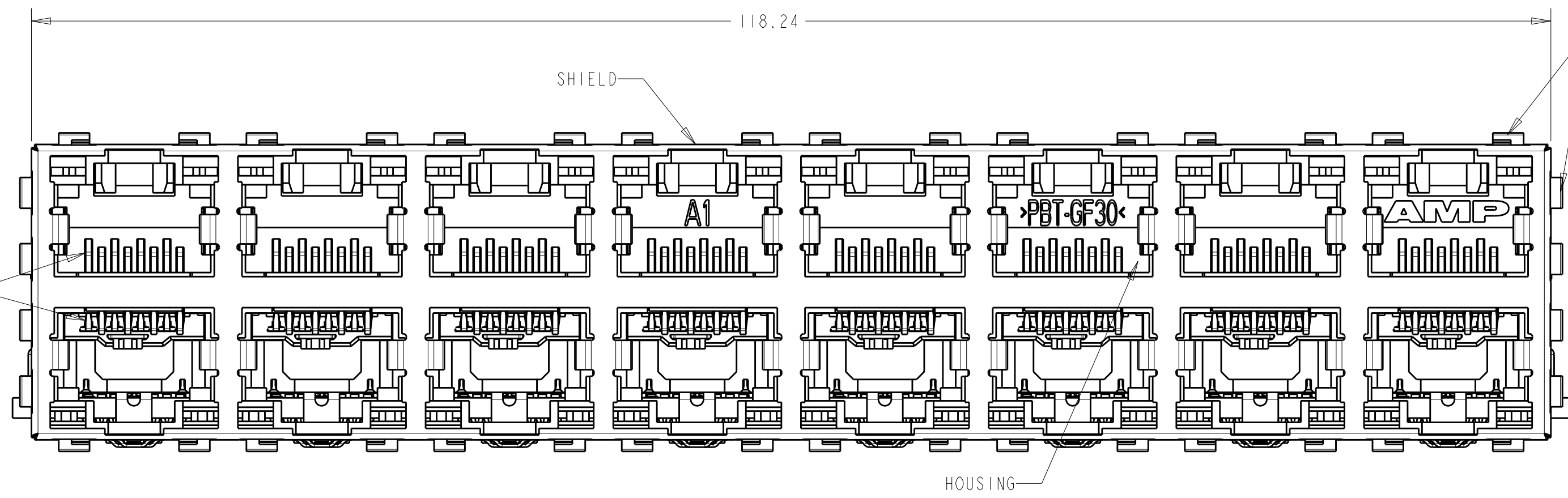
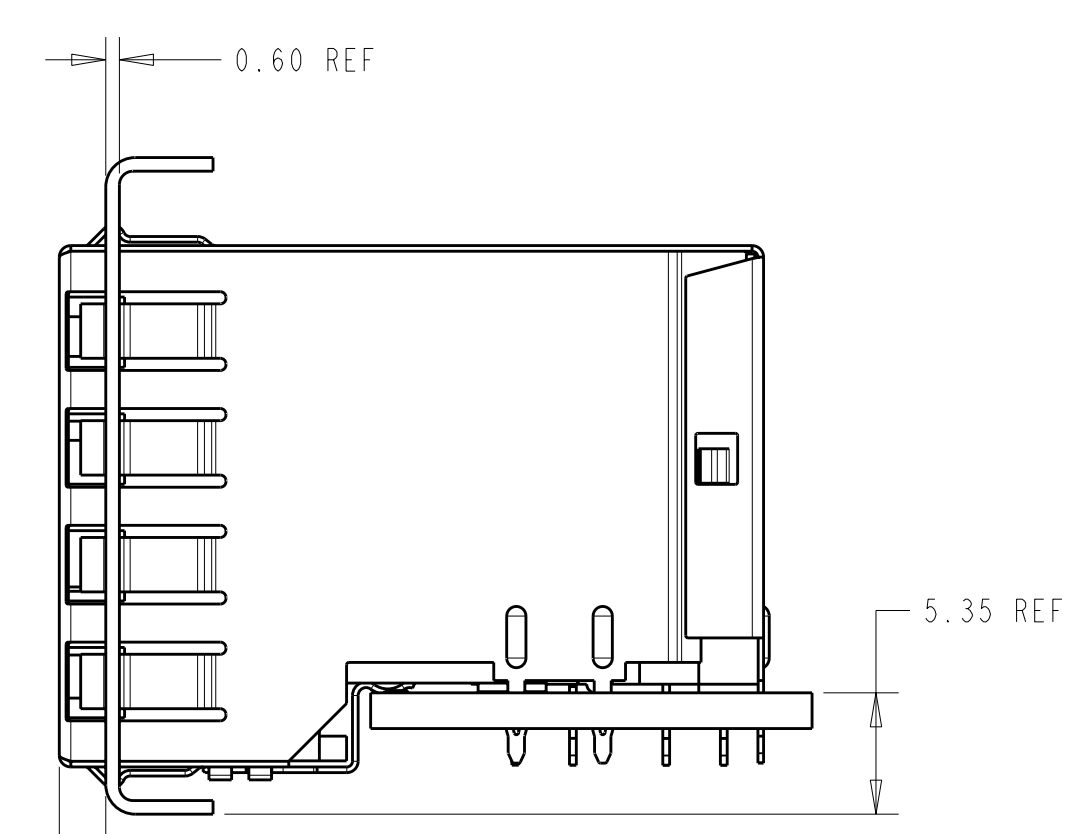

AMC PANEL AND PRINTED CIRCUIT BOARD ASSEMBLY LAYOUT

15.88	WITH GROUND CLIP	1888654-4
15.88	WITH GROUND CLIP	1888654-3 (SHOWN)
16.13	WITHOUT GROUND CLIP	1888654-2
16.13	WITHOUT GROUND CLIP	1888654-1
M DIM	DESCRIPTION	PART NUMBER

DIMENSIONS: mm 		TOLERANCES UNLESS OTHERWISE SPECIFIED: 9 PLC ± 1 PLC ±0.13 5 PLC ± 4 PLC ± ANGLES ±1° FINISH SEE NOTE 1		DWN L. A. MAYER 28OCT2006 CHK J. WESTMAN 28OCT2006 APVD S. FLICKINGER 28OCT2006 NAME STACKED MOD JACK ASSEMBLY, 2 X 8, 8 POSN, SHIELDED, PANEL GROUND, OFFSET, CAT 5 SIZE CAGE CODE DRAWING NO RESTRICTED TO A 1100779 C=1888654 SCALE 1:1 SHEET 1 OF 2 REV C	
MATERIAL SEE NOTE 1		FINISH SEE NOTE 1		Tyco Electronics Corporation Harrisburg, PA 17105-3608	
CUSTOMER DRAWING		WEIGHT -		PRODUCT SPEC 108-1854 APPLICATION SPEC 114-2160	

LOC	DIST	REV	DATE	BY	APPD
AA	00				
		1			
		2			

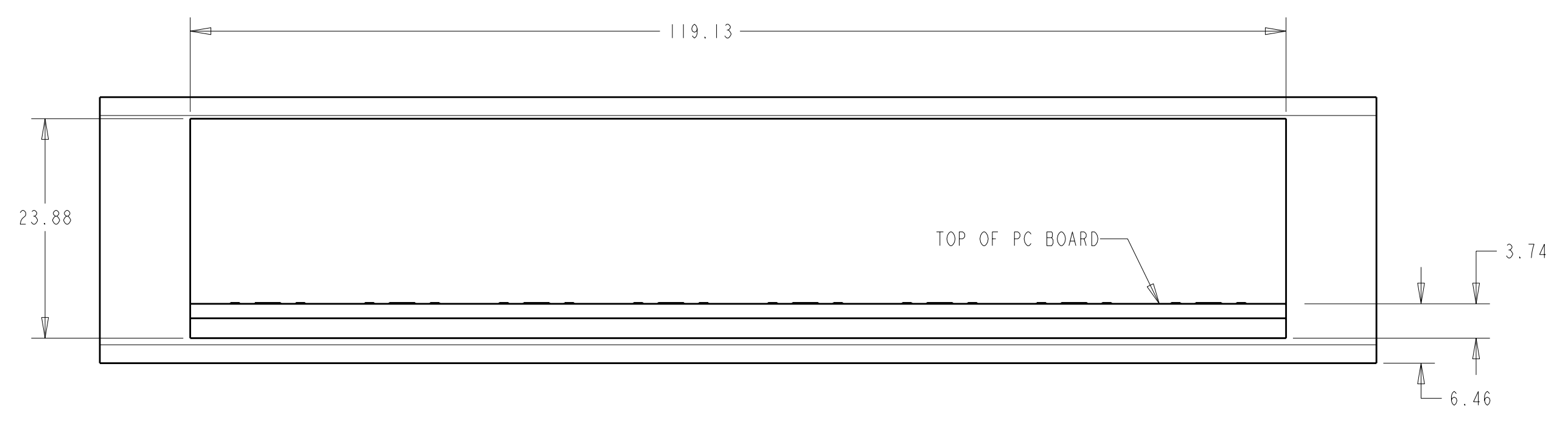

ATCA PANEL AND PRINTED CIRCUIT BOARD LAYOUT
 SCALE 2:1

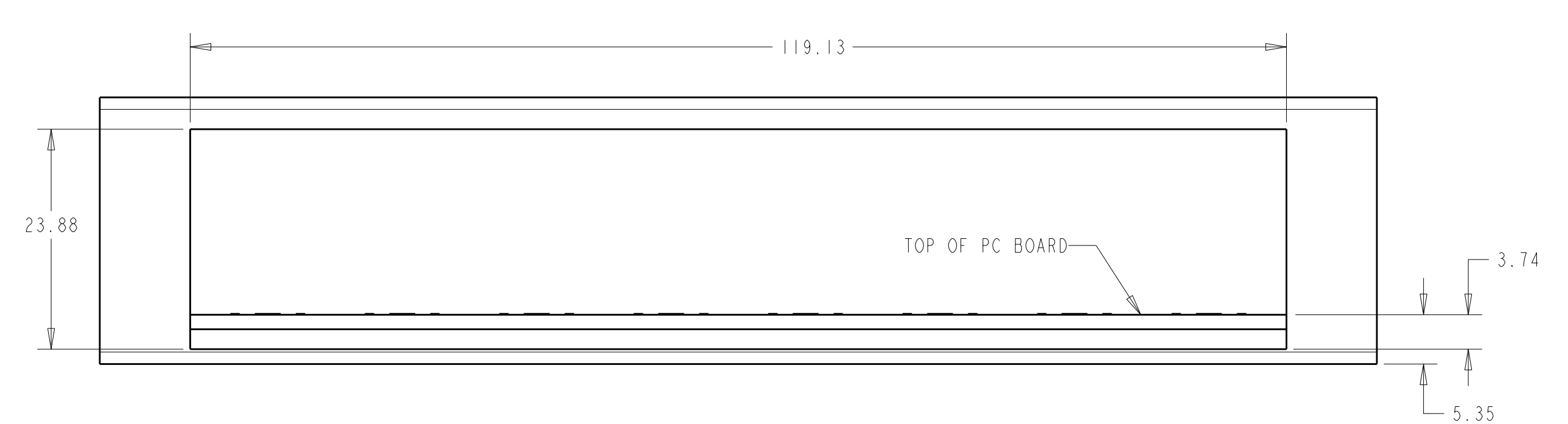

AMC PANEL AND PRINTED CIRCUIT BOARD LAYOUT
 SCALE 2:1

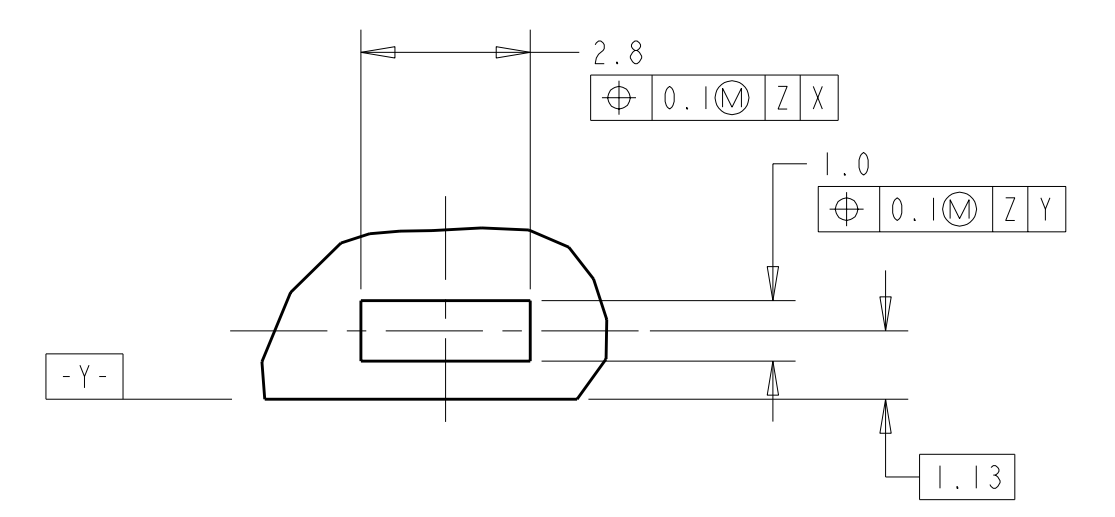

DETAIL B
 SCALE 8:1
 PLATED PADS REQUIRED FOR 1888654-3 & -4 (PRODUCT WITH GROUNDING CLIP) 8 PLC

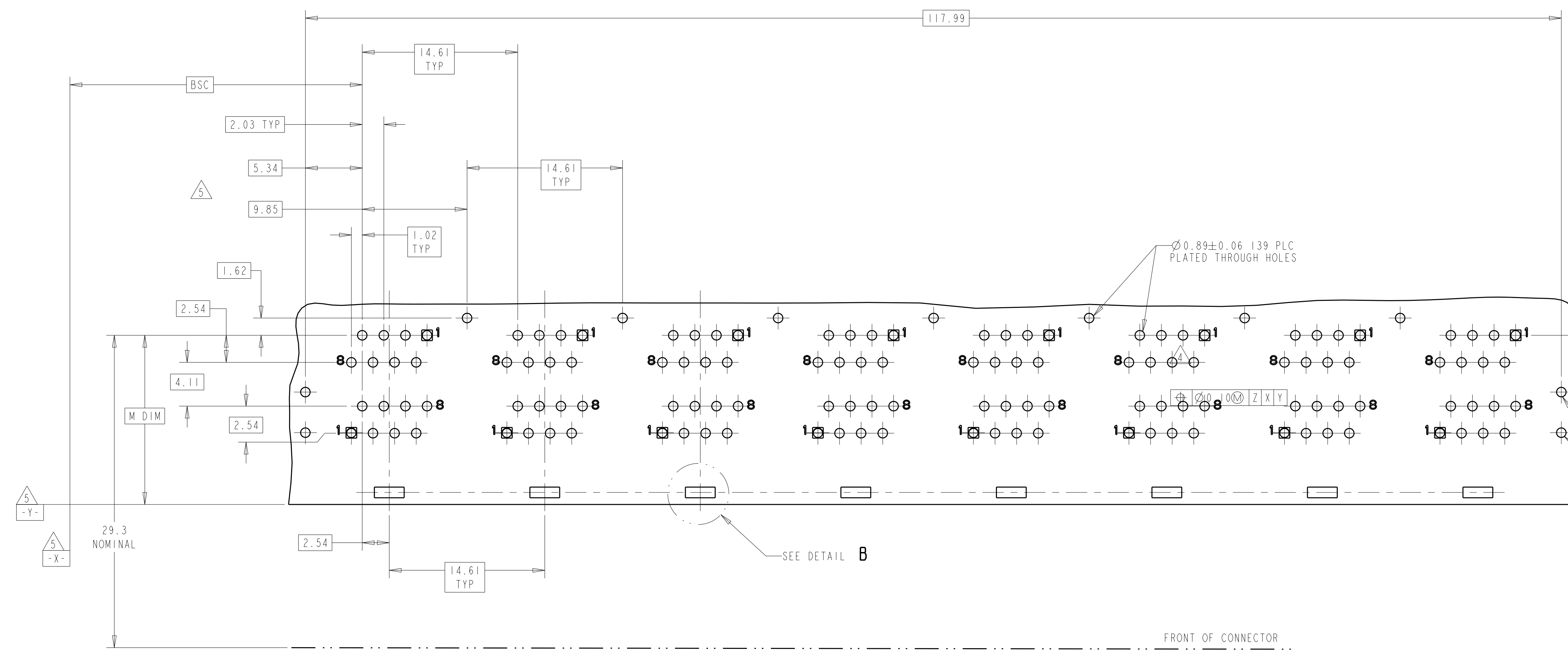

PC BOARD LAYOUT (COMPONENT SIDE)

DIMENSIONS: mm TOLERANCES UNLESS OTHERWISE SPECIFIED: 9 PLC ± 1 PLC ±0.13 5 PLC ± 4 PLC ± ANGLES ±1°		DWN L. A. MAYER 28OCT2006 CHK J. WESTMAN 28OCT2006 APVD S. FLICKINGER 28OCT2006 PRODUCT SPEC 108-1854 APPLICATION SPEC 114-2160 WEIGHT - FINISH SEE NOTE 1		Tyco Electronics Tyco Electronics Corporation Harrisburg, PA 17105-3608 NAME STACKED MOD JACK ASSEMBLY, 2 X 8, 8 POSN, SHIELDED, PANEL GROUND, OFFSET, CAT 5 SIZE CAGE CODE DRAWING NO RESTRICTED TO A1100779 C=1888654 SCALE 1:1 SHEET 2 OF 2 REV C	
MATERIAL SEE NOTE 1		CUSTOMER DRAWING			

单击下面可查看定价，库存，交付和生命周期等信息

[>>TE Connectivity\(泰科\)](#)