

LOC		DIST		P		F		ZONE		LTR		REVISIONS		DATE	APPD	
GP	00												DESCRIPTION			
													C	REV PER EC 0S13-0177-03	25/05/03	CR
													C1	REVISED PER ECO-09-023313	13/10/09	AEG

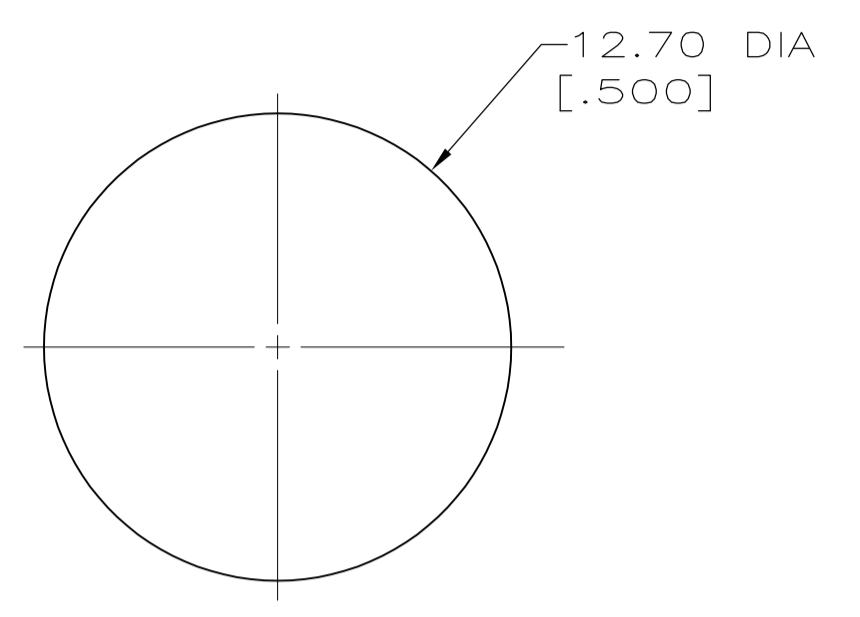

- ① SHELL: BRASS; CONTACTS: PHOSPHOR BRONZE; HOUSING: POLYESTER, UL 94V-0 RATED, BLACK.
- ② 0.76 μm [.000030] MIN GOLD ON MATING END FOR A LENGTH OF 1.37 [.054] MIN ON INSIDE, 2.54 μm [.000100] MIN TIN-LEAD FOR A LENGTH OF 3.30 [.130] MIN FROM OPPOSITE END, ALL OVER 1.27 μm [.000050] MIN NICKEL.
- ③ 0.38 μm [.000015] MIN GOLD ON MATING END FOR A LENGTH OF 1.37 [.054] MIN ON INSIDE, 2.54 μm [.000100] MIN TIN-LEAD FOR A LENGTH OF 3.30 [.130] MIN FROM OPPOSITE END, ALL OVER 1.27 μm [.000050] MIN NICKEL.
- ④ 2.54 μm [.000100] MIN TIN-LEAD OVER 1.27 μm [.000050] MIN NICKEL.
- ⑤ GOLD PLATING PER MIL-G-45204, TIN PLATING PER MIL-T-10727, NICKEL PLATING PER QQ-N-290.
- ⑥ RECEPTACLE ASSEMBLY MATES WITH 8 PIN, 8.99±0.10 [.354±.004] DIAMETER PLUG.
- ⑦ 2.54 μm [.000100] MIN TIN OVER 1.27 μm [.000050] MIN NICKEL.
- ⑧ OBSOLETE PARTS: OBSOLETE CIS STREAMLINING PER D.RENAUD/D.SINISI

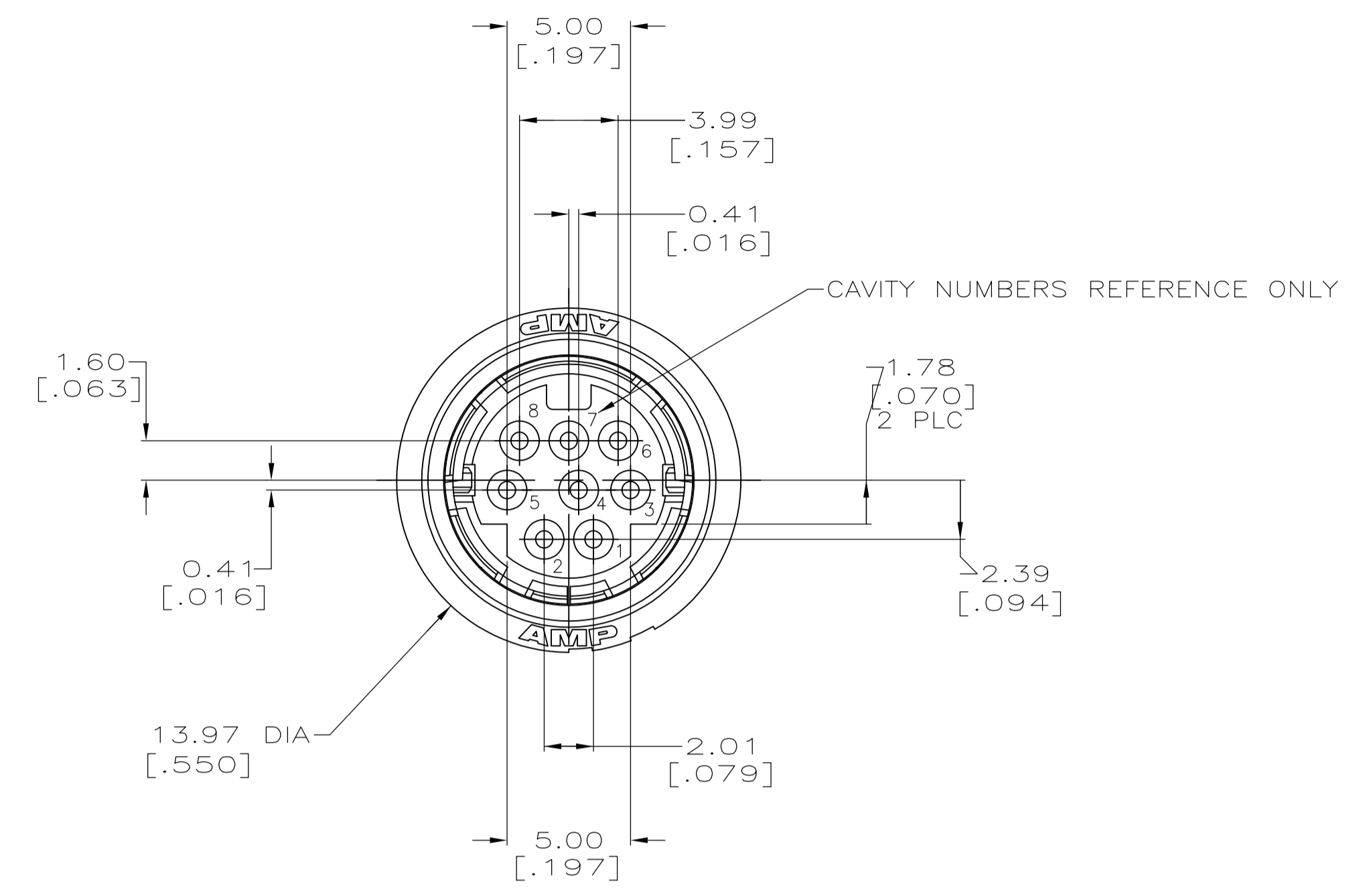
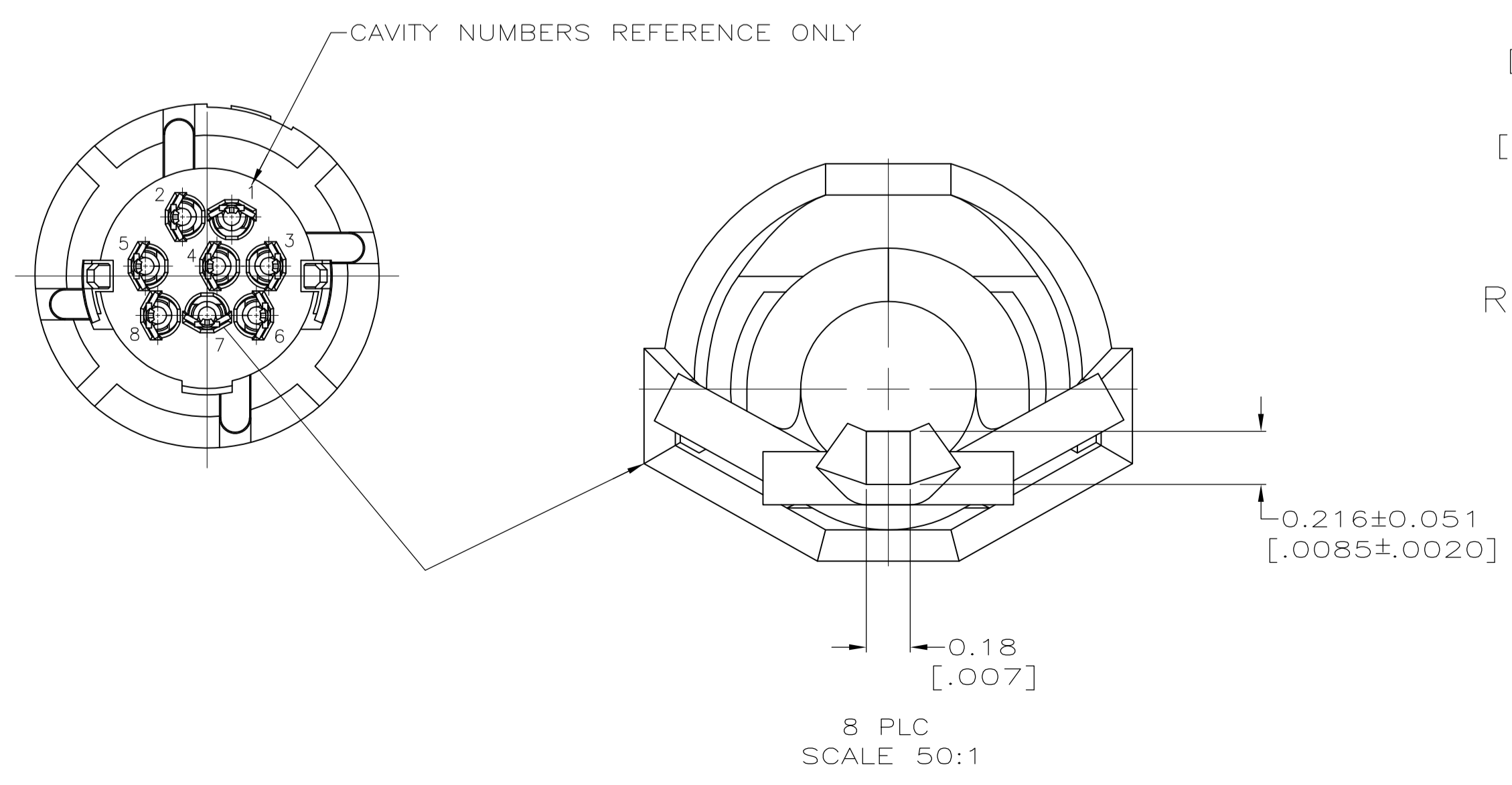
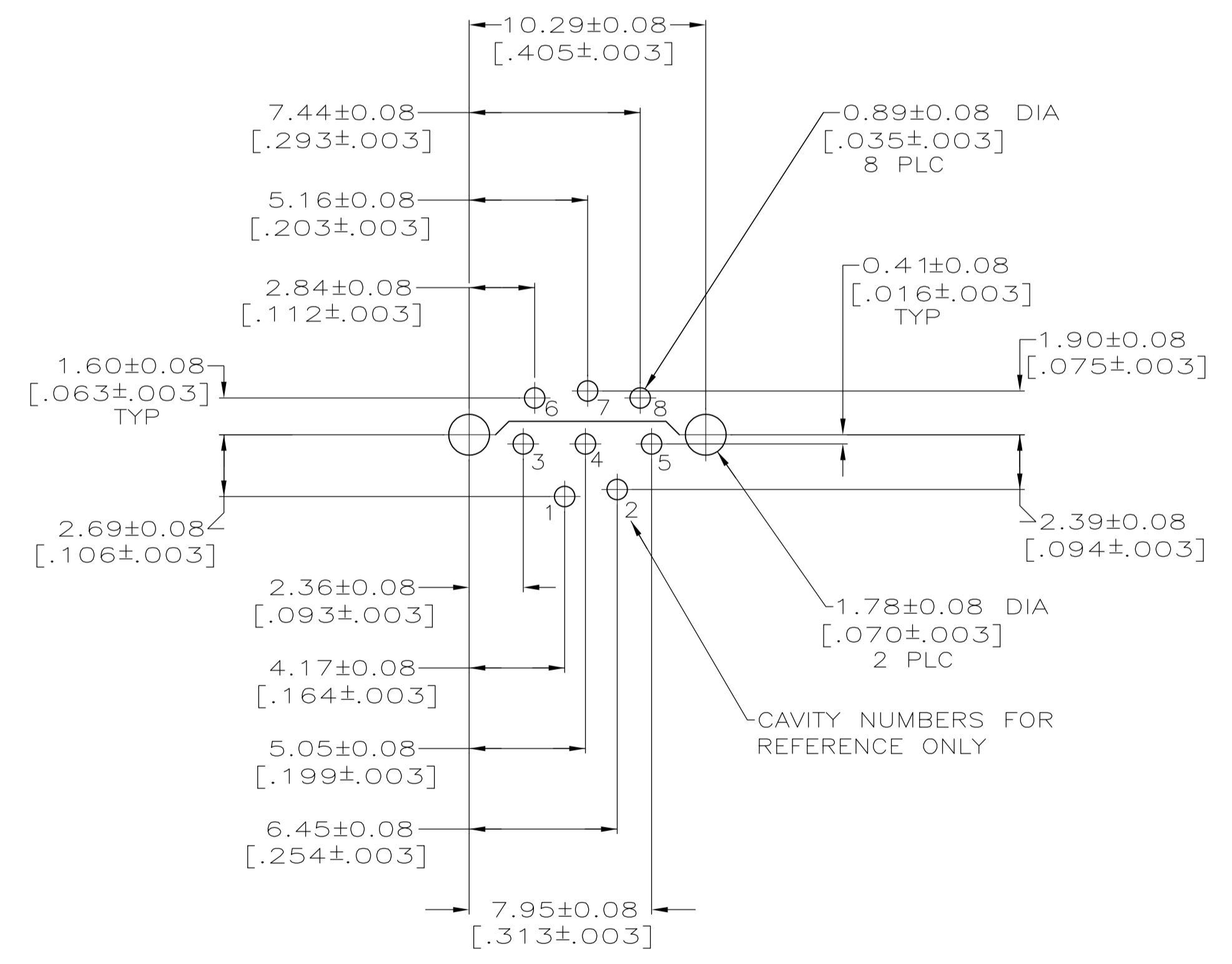
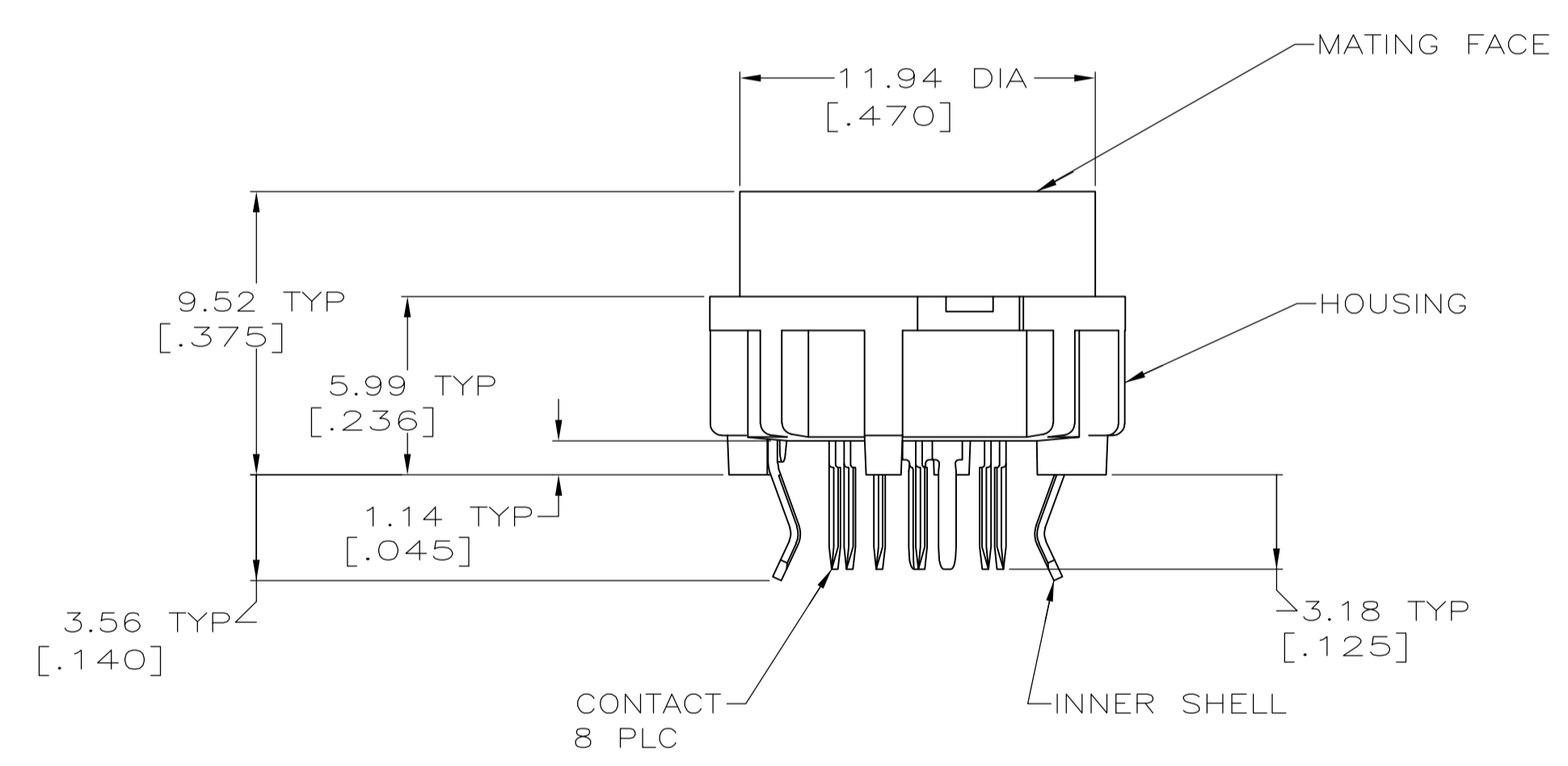

RECOMMENDED PC BOARD LAYOUT
BOTTOM VIEW

⑧ OBSOLETE	⑦	②	⑤	750337-3
④	⑤	②	⑤	750337-2
④	⑤	③	⑤	750337-1

MATERIAL		INNER SHELL FINISH	CONTACT FINISH	PART NO
DO NOT SCALE PRINT. UNLESS SPECIFIED DIMENSIONS IN mm [INCHES] TOLERANCES ON: 2 PLC DEC ± 0.13 [.005] 3 PLC DEC ± - ANGLES ± -	DR 8-2-90 J McCLINTON CHK 9-5-90 R.STONE APPD 9-5-90 R.WHYNE APPD 9-10-90 J.FULPONI			750337-3 750337-2 750337-1
FINISH SEE TABLE	APPLICATION SPEC -	SIZE D	CAGE CODE 00779	DRAWING NO 750337
	WEIGHT -	SCALE 5:1	SHEET 1 OF 1	

AMP AMP Incorporated
Harrisburg, PA 17105-3608

NAME
RECEPTACLE ASSEMBLY, 8 POSN,
LOW FLANGE, UNSHIELDED,
VERTICAL, MINIATURE CIRCULAR DIN

单击下面可查看定价，库存，交付和生命周期等信息

[>>TE Connectivity\(泰科\)](#)