



**AMP* INSERTION TOOLS 91039
FOR TYPE XV
PIN AND SOCKET CONTACTS**

Instruction Sheet IS 7371	
RELEASED	1-8-86

REDUCED FOR PACKAGING

Section I of this instruction sheet provides application procedures for AMP insertion tools.

Section II provides maintenance and inspection procedures for AMP insertion tools.

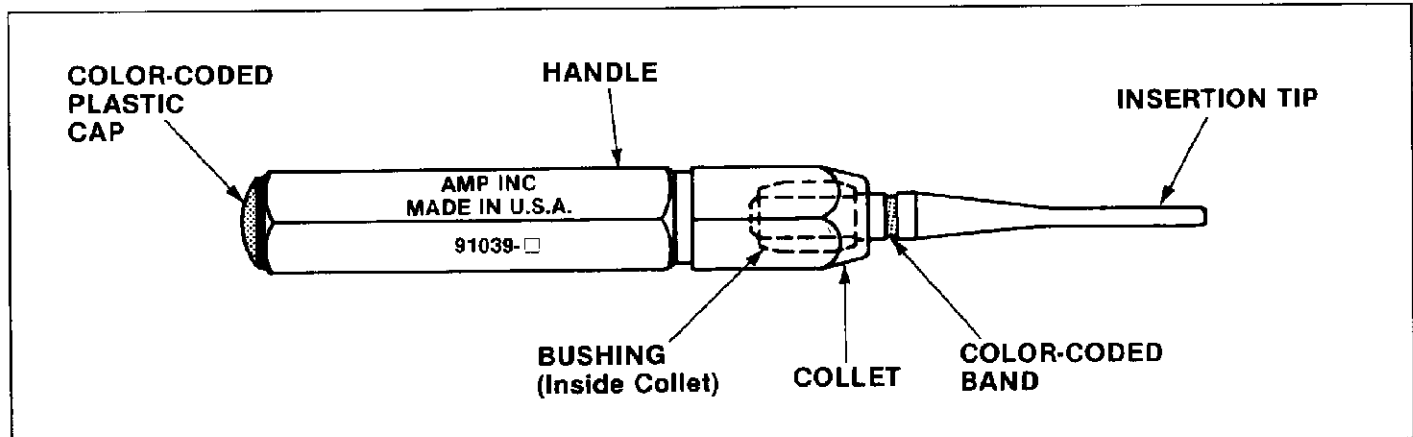

PART NUMBERS				CONTACT SIZE	COLOR CODE
TOOL	TOOL TIP	CONTACTS			
		PIN	SOCKET		
91039-1	126117-1	203840-2	203841-1	SUB-SIZE 20	GREEN
91039-3	126117-3	203884-2	203885-1	SIZE 16	BLUE

Fig. I-1

SECTION I APPLICATION

I-1. INTRODUCTION

AMP Insertion Tools 91039-1 and -3 are designed to insert AMP Type XV pin and socket contacts into AMP ARINC-type rack and panel connectors. The contacts and the compatible tools and tips are listed in Figure I-1. Read all instructions carefully before using the tool.

NOTE All dimensions presented in this instruction sheet are in inches.

I-2. DESCRIPTION

Each tool features a metal handle with a plastic cap, a collet containing a metal bushing, and a metal insertion tip. The cap and the insertion tip are color-coded for easy identification, and the colors correspond with the color marking on the contact. See Figure I-1.

Two versions of the insertion tool are available. The difference between them is in the insertion tip; each tip is designed for a different contact size as shown in Figure I-1.

I-3. CONTACT INSERTION

Determine the size of the contact to be inserted, and then check the dash number and color code of the tool in Figure I-1 to make sure that the proper tool is selected. After selecting the proper tool, proceed as follows:

1. Place the contact in the tool tip so that the shoulder of the contact butts against the end of the tool tip as shown in Figure I-2.
2. Holding the wire in the slot of the tip, push the contact straight into the cavity until the contact bottoms. Make sure the tool remains centered over the cavity.
3. Pull the tool straight out of the cavity.
4. Check for proper contact insertion by pulling back lightly on the wire, ensuring that the contact is locked in place. The contact is held in place with a retaining spring in the insert of the connector.

I-4. TOOL TIP REPLACEMENT

If the tool tip becomes damaged and requires replacement, order a new tip using the part number specified in Figure II-1. To replace the tool tip, proceed as follows:

© Copyright 1968, 1970, 1986 by AMP Incorporated, Harrisburg, PA. All International Rights Reserved. AMP Incorporated products covered by U.S. and Foreign patents and/or patents pending.

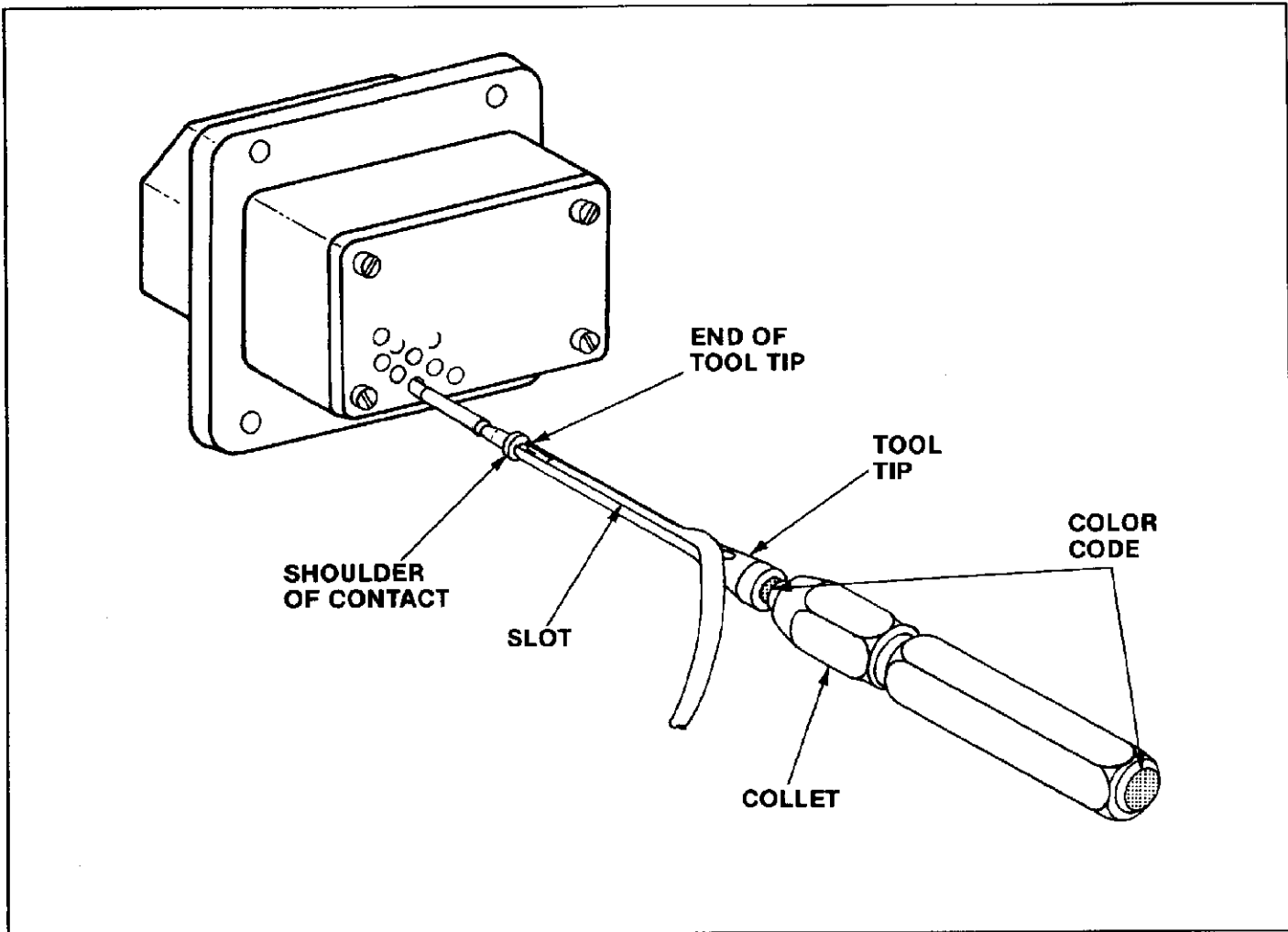

Fig. I-2

1. Secure the handle of the tool with a suitable clamp, and then rotate the collet in a counterclockwise direction until the tip is loosened enough to be removed.
2. Remove and discard the damaged tip;

then insert the replacement tip into the tool bushing, making sure that the shoulder of the tip seats on the bushing inside the collet.

3. While holding tip in position, tighten collet by turning it clockwise until it retains tip in tool.

Section I of this instruction sheet provides application procedures for AMP insertion tools.

Section II provides maintenance and inspection procedures for AMP insertion tools.

SECTION II—MAINTENANCE/INSPECTION

II-1. TOOL CERTIFICATION

The tool is assembled and certified before shipment. It is suggested that the tool be inspected immediately upon its arrival in your plant to ensure that it has not been damaged during shipment, and that it conforms to the dimensions given in Figure II-1.

II-2. MAINTENANCE AND INSPECTION

The tool requires little maintenance other than to ensure that it is kept clean and properly stored in a clean, dry area when not in use. It may be cleaned with a clean, soft, lint-free cloth. Take care not to allow any foreign objects to become lodged in the insertion tip. When not in use, the tool should be so placed that it offers maximum protection for the tip. Inspections should be performed by quality control

personnel on a regularly scheduled basis, with a record of inspections remaining with the tool or supplied to supervisory personnel responsible for the tool.

II-3. REPAIR

The insertion tips are customer-replaceable and are listed by part number in Figure II-1. An inventory of the tips can be stocked and controlled to avoid lost time when replacement of parts becomes necessary. If desired, tools may be sent to AMP Incorporated for evaluation and repair. Send the tool with a written description of the problem to:

AMP Incorporated
Customer Repair
1523 North 4th Street
Harrisburg, PA, 17102-1604

or a wholly owned subsidiary of AMP Incorporated.

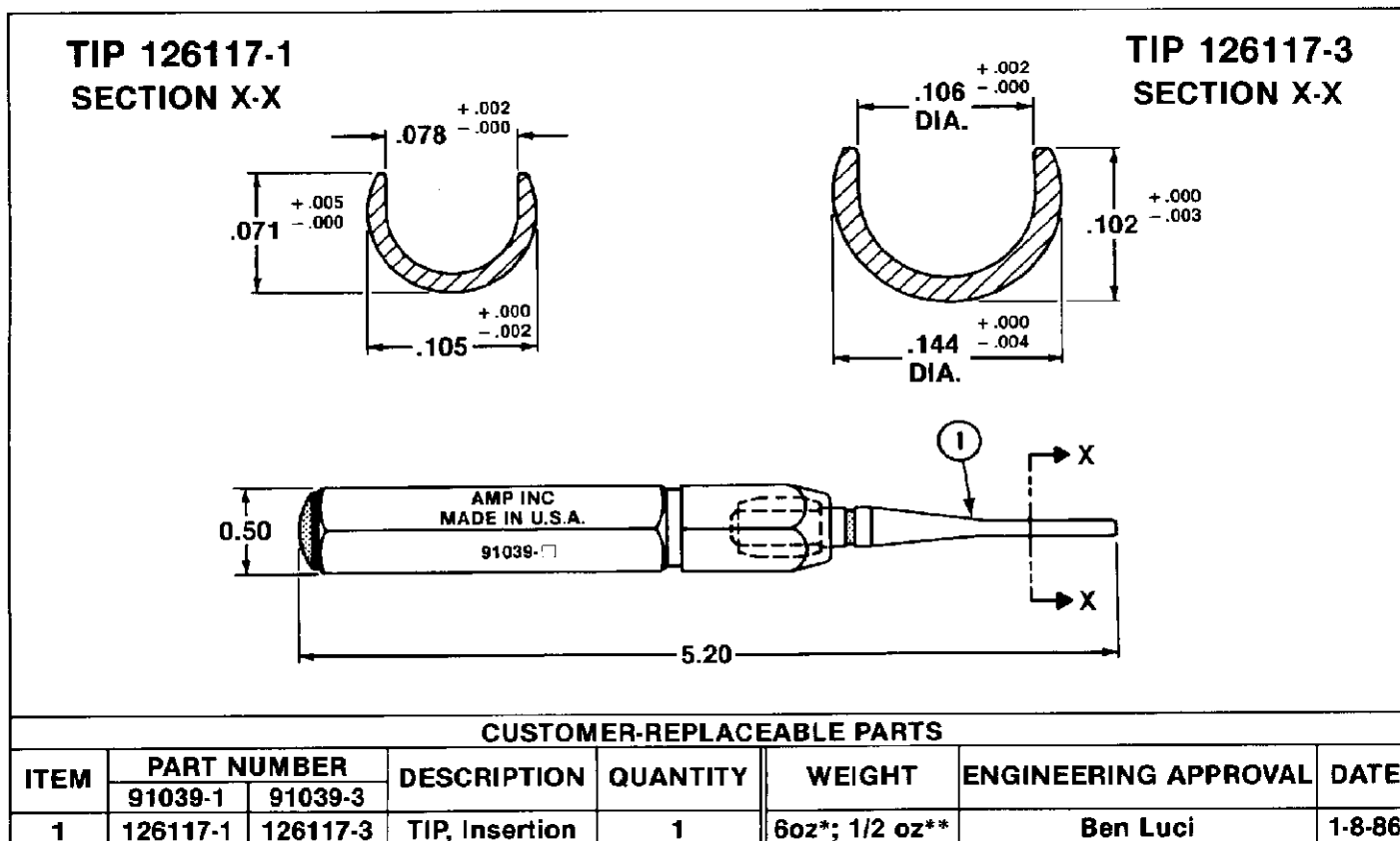

* COMPLETE TOOL.
** TOOL TIP ONLY.

Fig. II-1

单击下面可查看定价，库存，交付和生命周期等信息

[>>TE Connectivity\(泰科\)](#)