

P	LTR	DESCRIPTION	DATE	DWN	APVD
2		CORRECTED CONNECTOR DIMENSION	18MAY2020	CL	SZ
3		ADDED UMCC MATING DIM	18MAY2020	CL	SZ
3		ECR-15-001339	18MAY2020	CL	SZ

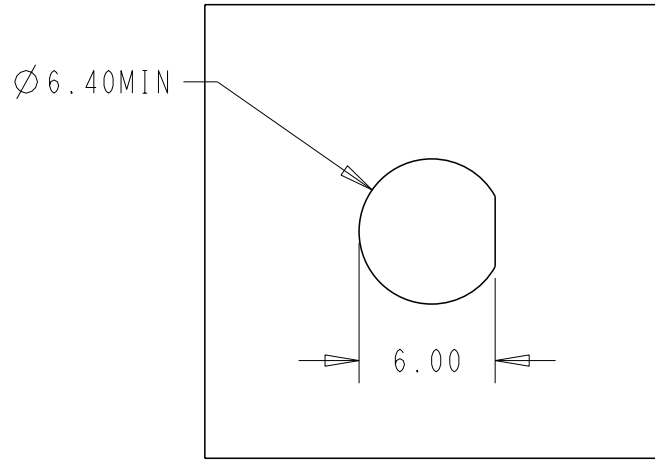

RECOMMENDED MOUNTING HOLE

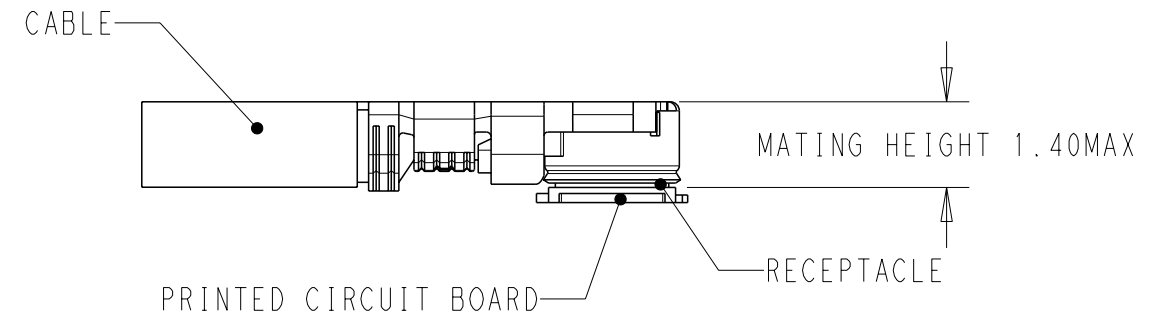

THIS PRINT IS
PRELIMINARY

UNQUALIFIED PRODUCT
CONTACT PRODUCT ENGINEERING
BEFORE USING THIS PRINT

2016694-9	500±5
2016694-8	450±5
2016694-7	350±5
2016694-6	300±3
2016694-5	250±3
2016694-4	200±3
2016694-3	150±3
2016694-2	100±3
2016694-1	50+3
PART NUMBER	LENGTH

- NOTES:
- MATERIAL AND PROCESSING MUST MEET REQUIREMENTS OF TEC-138-702
 - SMA BULKHEAD NEED ASSEMBLY NUT AND WASHER
 - PRODUCT RATING:
TEMPERATURE: -45°C TO +85°C
VOLTAGE: 30V (RMS)
CHARACTERISTIC IMPEDANCE: 50 OHMS Normal
FREQUENCY RANGE: DC TO 6GHz
BEND RADIUS: 5MM MIN
 - CABLE ASSEMBLY TO BE 100% SI TESTED
VSWR:
1.3:1 MAX @ DC~1000MHz
1.5:1 MAX @ 1000~4000MHz
2.0:1 MAX @ 4000~6000MHz
INSERT LOSS: (2.60*LENGTH+0.4)dB MAX @2GHz
LENGTH UNIT IS METER IN THE FORMULA
 - SMA INTERFACE FOLLOW IEC 60169-15
UMCC IV CAN MATE WITH I-PEX MHF4L SERIES AND HIROSE U.FL SERIES

PC	Q'TY	UNIT	DESCRIPTION	ITEM
PC	1		HEAT SHRINK TUBE	3
PC	0.5		RF CA,UMCC4 BOTH END, WITH 1.13CABLE	2
PC	1		SMA BULKHEAD, FOR 1.13 CABLE	1

THIS DRAWING IS A CONTROLLED DOCUMENT.		DWN 25FEB2019 Cedar Liu		
		CHK 26FEB2019 Roger Song		
DIMENSIONS: mm		APVD - Roger Song	NAME RF CA,SMA BULKHEAD TO UMCC GEN4 WITH 1.13 CABLE	
		PRODUCT SPEC -	-	
TOLERANCES UNLESS OTHERWISE SPECIFIED: 0 PLC ±- 1 PLC ±0.5 2 PLC ±0.13 3 PLC ±0.013 4 PLC ±0.0001 ANGLES ±-		APPLICATION SPEC -	-	
MATERIAL TBD		WEIGHT -	SIZE A3	CAGE CODE 00779
FINISH - finish_spec_2		CUSTOMER DRAWING	DRAWING NO C-2016694	RESTRICTED TO -
		SCALE 1:1	SHEET 1 OF 1	REV 3

单击下面可查看定价，库存，交付和生命周期等信息

[>>TE Connectivity\(泰科\)](#)