

REVISION(S)			
LTR	DESCRIPTION	INIT	APP'D
O	ECN: 0S60-0271-04	E.T 11/3/04	B.P 11/22/04
A	ECR-06-020585	E.T 8/25/06	V.K 8/25/06

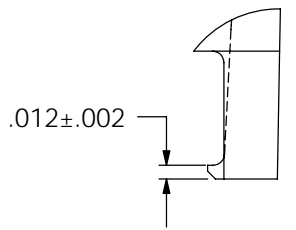

DETAIL A  
SCALE = 6X

- MATERIAL:  
HEAT SINK: ALUM. (BLACK ANODIZE)  
CLIP: BLACK PEI (UL94-VO)
- BEFORE THE HEATSINK APPLICATION, THE USER SHOULD IDENTIFY THE SPECIFICATION OF MAXIMUM LOAD ON THE BGA PACKAGE.  
HEATSINK TORQUE SPECIFICATIONS CONVERTED TO FORCE.  
BARE DIE PACKAGE:  
2.0 POUND-FORCE INCH TORQUE = 8.1 POUND-FORCE (0.23 NEWTON METER TORQUE = 36.03 NEWTON)  
2.5 POUND-FORCE INCH TORQUE = 10.1 POUND-FORCE (0.28 NEWTON METER TORQUE = 44.93 NEWTON)  
FULL SIZE LID PACKAGE:  
2.0 POUND-FORCE INCH TORQUE = 6.9 POUND-FORCE (0.23 NEWTON METER TORQUE = 30.69 NEWTON)  
2.5 POUND-FORCE INCH TORQUE = 8.7 POUND-FORCE (0.28 NEWTON METER TORQUE = 38.70 NEWTON)
- REMOVE CLIP WITH REMOVAL TOOL P/N: 1542616-1
- RoHS COMPLIANT AND CERTIFIED.

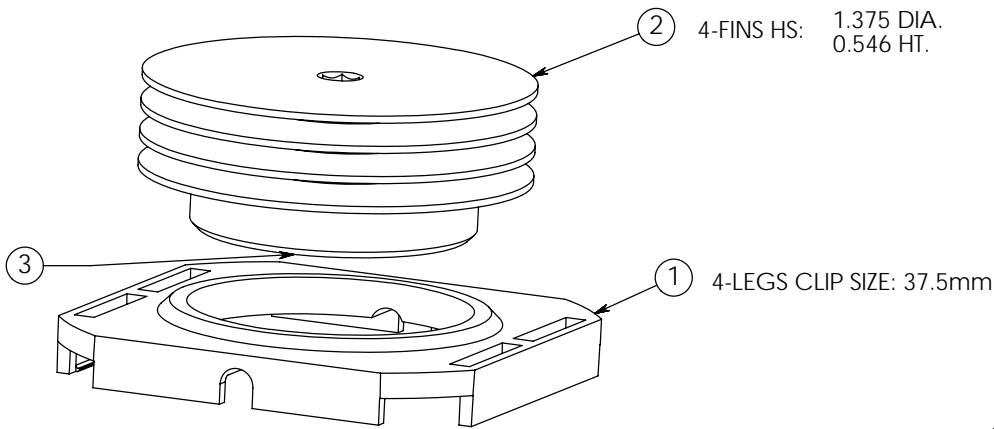
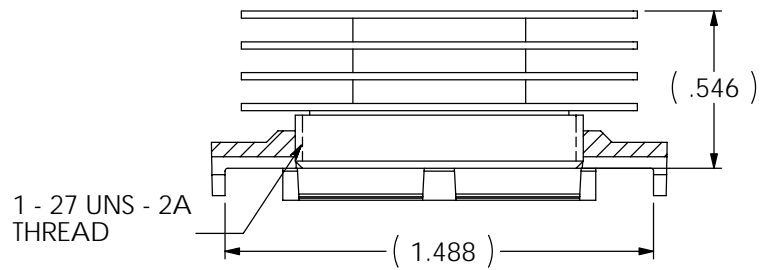
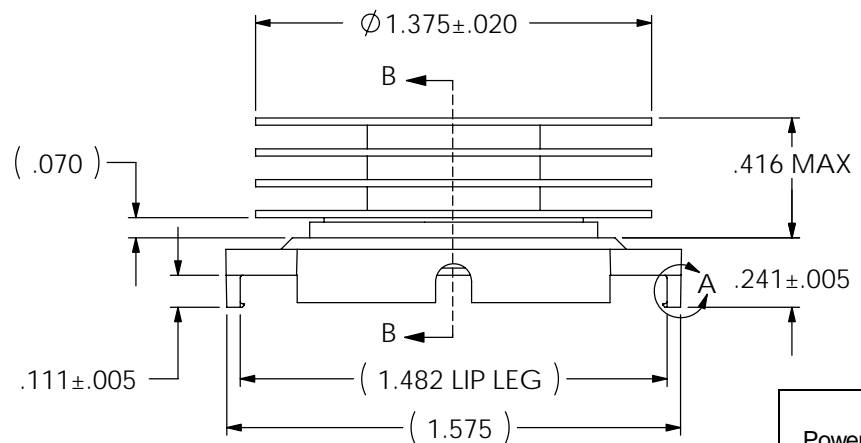

SECTION B-B

Power	° C/W @ Ambient	° C/W @ 200 LFM	° C/W @ 400 LFM	° C/W @ 600 LFM
5 Watts	10.81	4.79	3.30	2.15
10 Watts	9.81	4.89	3.34	2.30
15 Watts	9.13	5.11	3.45	2.40

**CUSTOMER DRAWING**

SPECIFICATIONS ARE SUBJECT TO CHANGE WITHOUT NOTICE

ITEM	DESCRIPTION	QTY
1	MOUNTING CLIP	1
2	HEAT SINK	1
3	INTERFACE	1

**tyco** / Electronics  
Atteboro Falls Massachusetts 02763

UNLESS OTHERWISE SPECIFIED TOLERANCES ARE:  
.XX ±  
.XXX ±  
.XXXX ±  
ANGLES ± \*

DRAWN BY: E.TAO  
DATE: 11/9/04  
MATERIAL: SEE NOTE

ENGINEER: B.PETROCELLI  
DATE: 11/22/04  
FINISH: SEE NOTE

FILENAME: PROJECT: SYSTEM:

CONFIDENTIAL PROPERTY OF TYCO ELECTRONICS. NOT TO BE DISCLOSED TO OTHERS. REPRODUCED OR USED FOR ANY PURPOSES EXCEPT AS AUTHORIZED IN WRITING BY AN AUTHORIZED OFFICIAL OF TYCO. MUST BE RETURNED TO TYCO ON DEMAND, ON COMPLETION OF ORDERS OR OTHER PURPOSES FOR WHICH LENT.

TITLE: **37.5mm HEATSINK ASSEMBLY (HTS406-P)**

DIMENSIONS ARE IN: INCHES  
SCALE: 1.5:1  
PART NO: **3-1542002-0**  
SHEET: 1 OF 1

SIZE: **A**  
DWG. NO. **C-3-1542002-0**  
REV: **A**

单击下面可查看定价，库存，交付和生命周期等信息

[>>TE Connectivity\(泰科\)](#)