

Scale 8

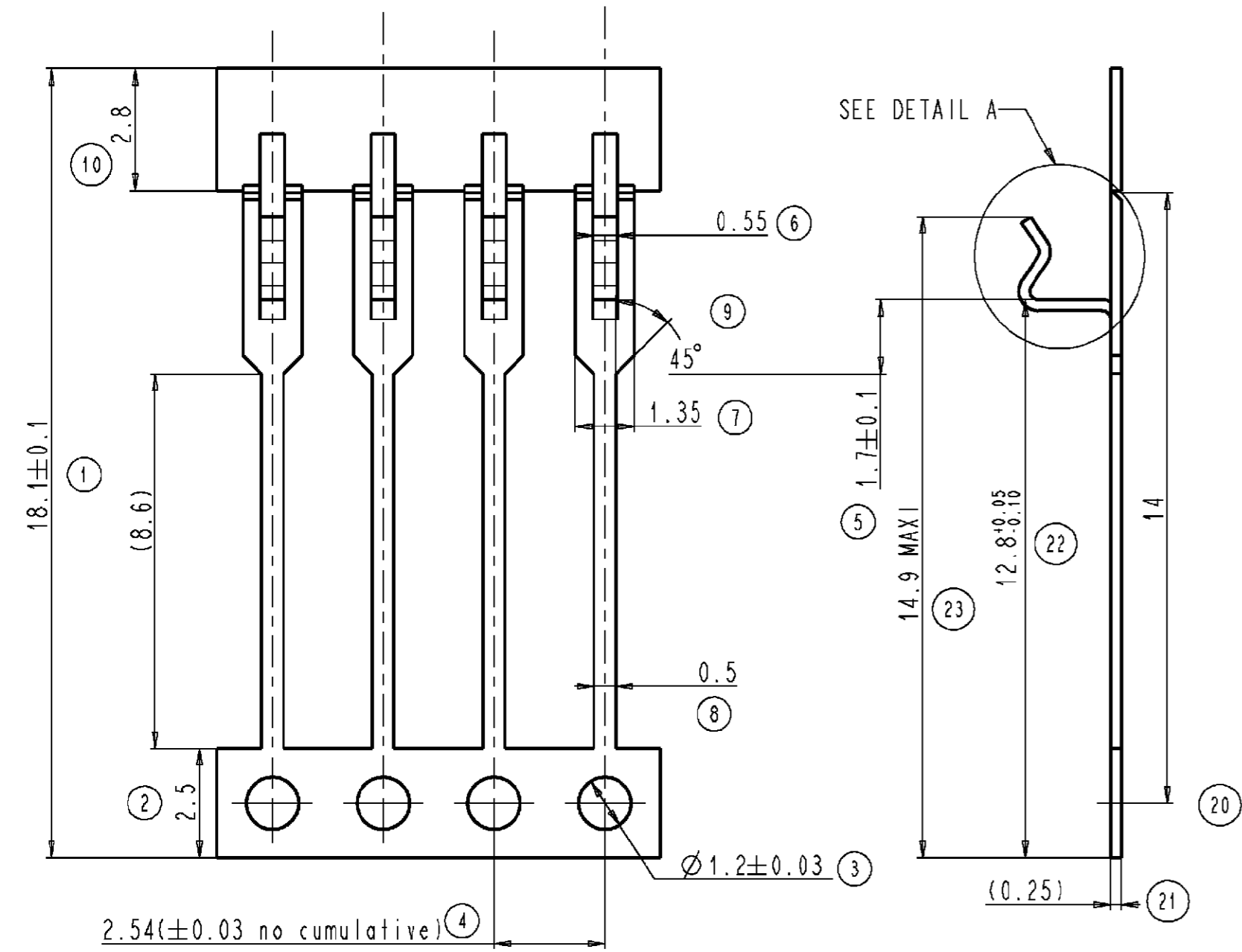

DETAIL A
Scale 50

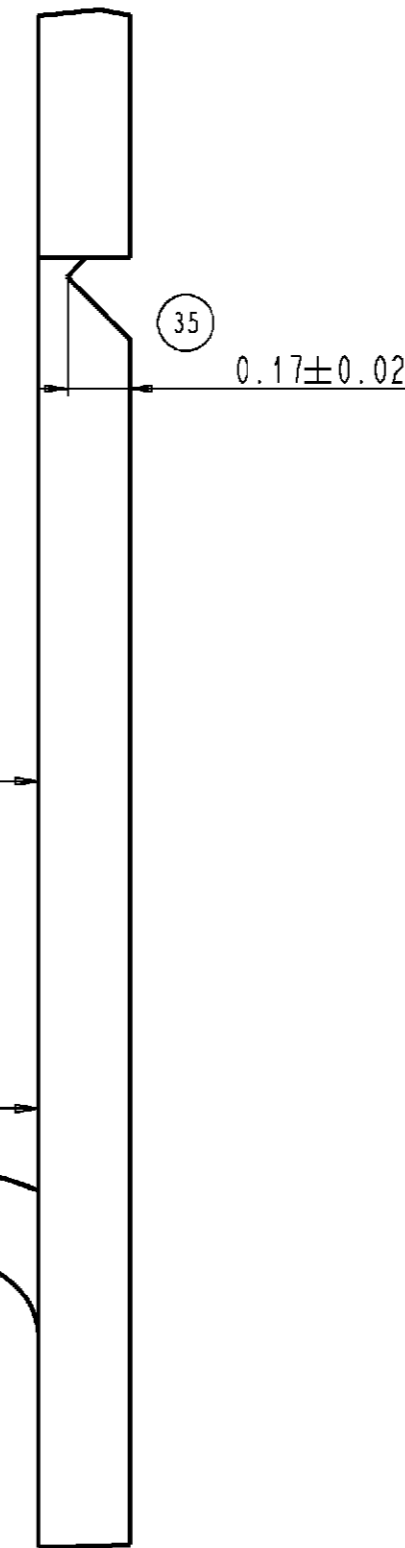
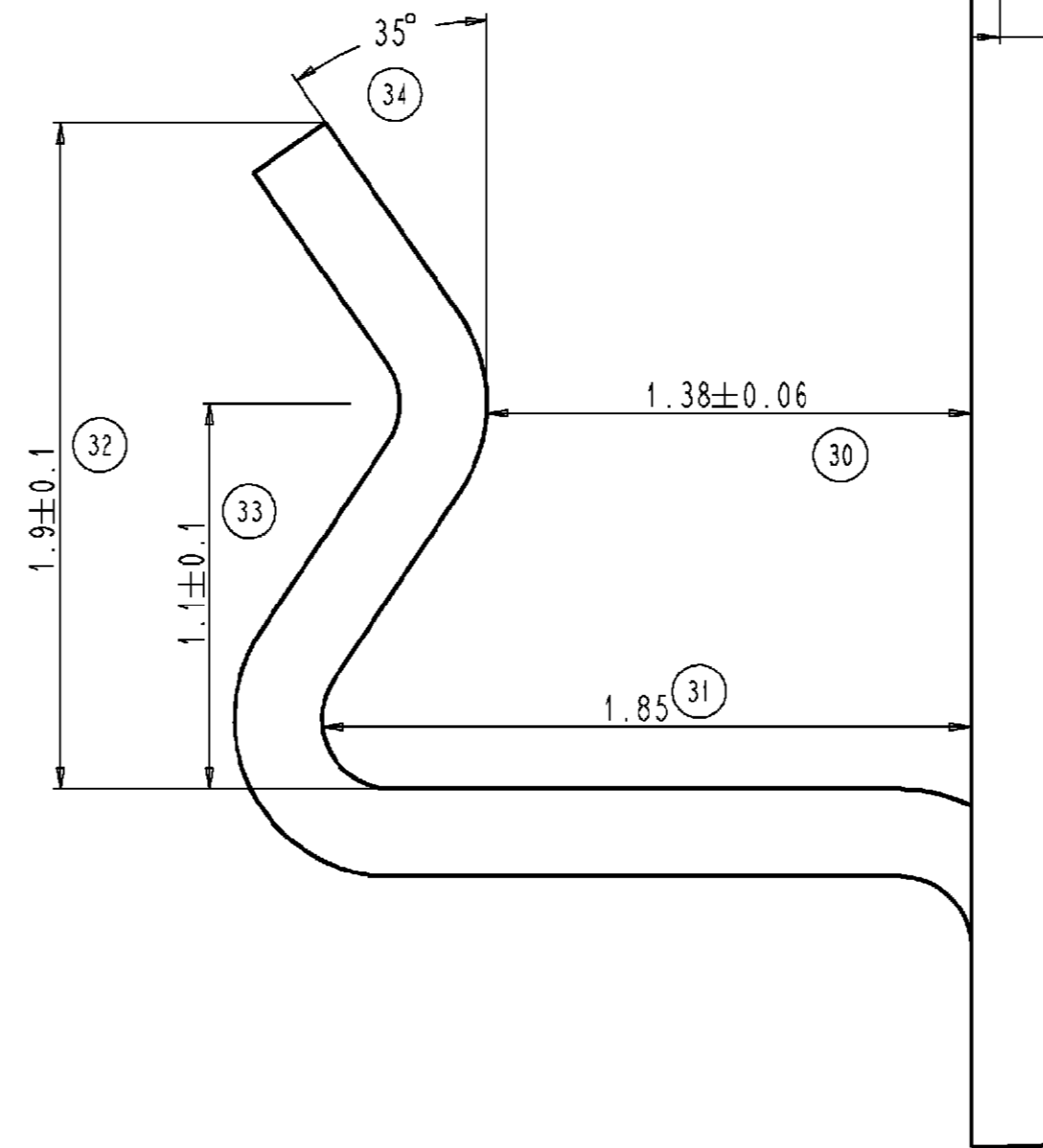

Scale 5

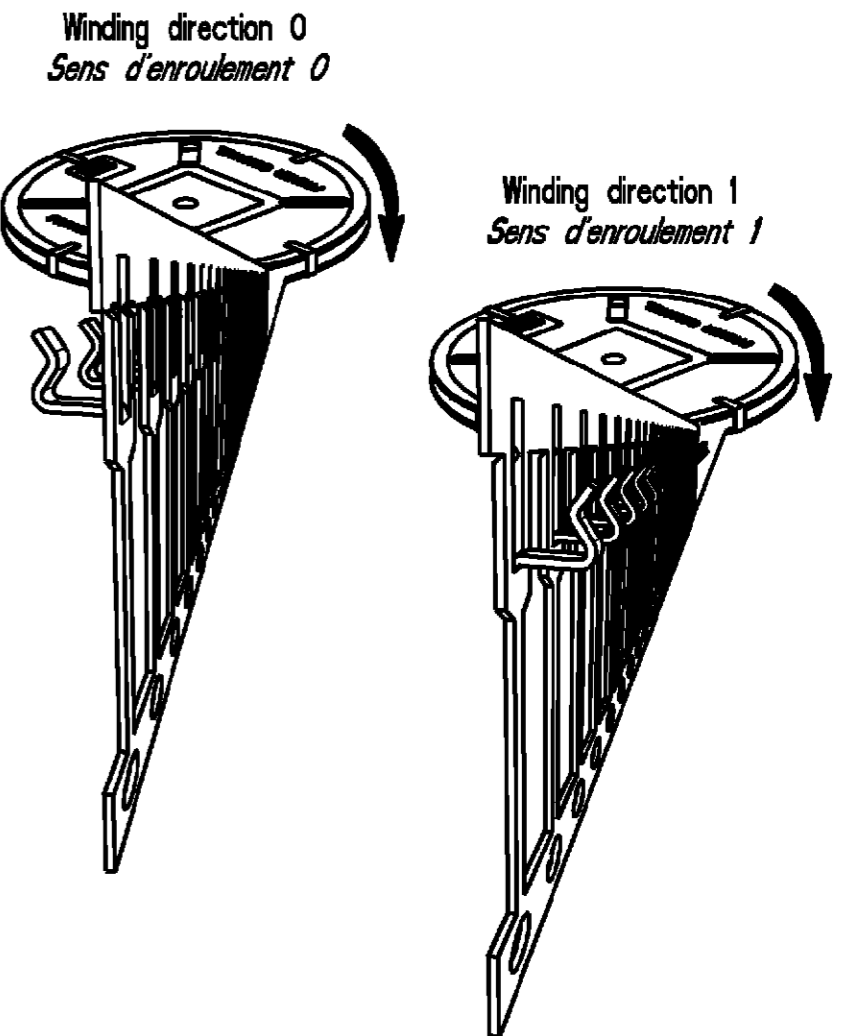
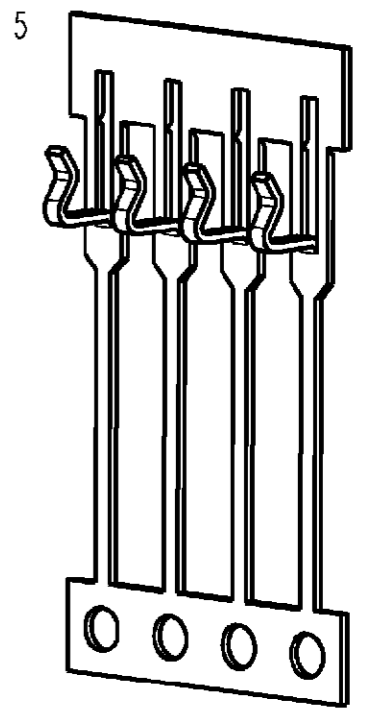

◆ BOWING: After upper tie bar removal: 1.5mm Maxi for 500mm
 ◆ SABRE: Après séparation du tie bar: 1.5mm Maxi sur 500mm
 ◆ PITCH: After upper tie bar removal: 2.54±0.127
 ◆ PAS: Après séparation du tie bar: 2.54±0.127

TYCO P/N	PRONER COMATEL P/N	PLATING	WINDING DIRECTION
0-1544210-1	510 2180 042 111	BEFORE STAMPING	0
0-1544207-1	510 2180 142 111	Sn: 112-16-4 :3 à 7 µ	1
0-1544210-2	510 2180 044 111	AFTER STAMPING	0
		Ni: 112-25-3 :1,27 à 3 µ Sn: 112-65-1 :4 µ mini	0

Reference/Designation	Material	Treatment	Protection	Quantity
See table	Phosphorous bronze	/	See table	/
Sub-Assy.: //				
Assembly: //				

Lead frame SIL

PRONER COMATEL
 DEPARTEMENT TECHNIQUE
 38530 CHAPAREILLAN
 Tél: 04 76 45 34 34 Fax: 04 76 45 28 21

Scale: 8 Mass: //
 Lin. Tol.: ± 0.05
 Ang. Tol.: ± 7°
 Format A2

4465 D 001

Reproduction and diffusion forbidden without Proner Comatel agreement

Description of Modification	N° Avis Modif.	Drawn by	Date	Checked by	Ind.
ER00-0283-04		SRd	11/6/04		B
MAJ, ajout enroulement annule et remplace 2180 B2, 2454	1482	JDJ	24.08.2001	...	AI

单击下面可查看定价，库存，交付和生命周期等信息

[>>TE Connectivity\(泰科\)](#)