

LOC	DIST	REV	DESCRIPTION	DATE	BY	APPV
DF	AO	C	REVISED PER ECO-13-002054	05FEB2013	MGM	CT

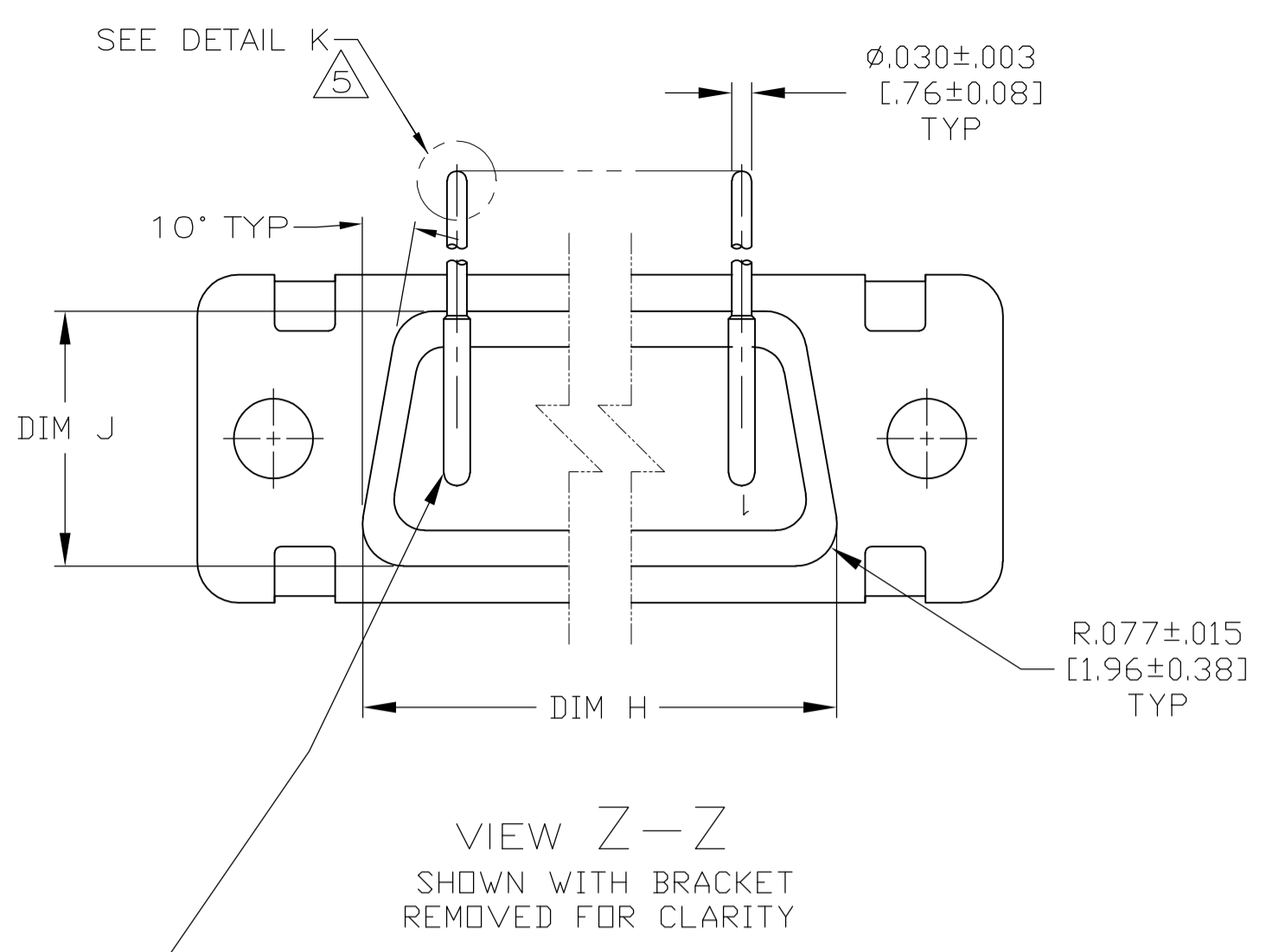
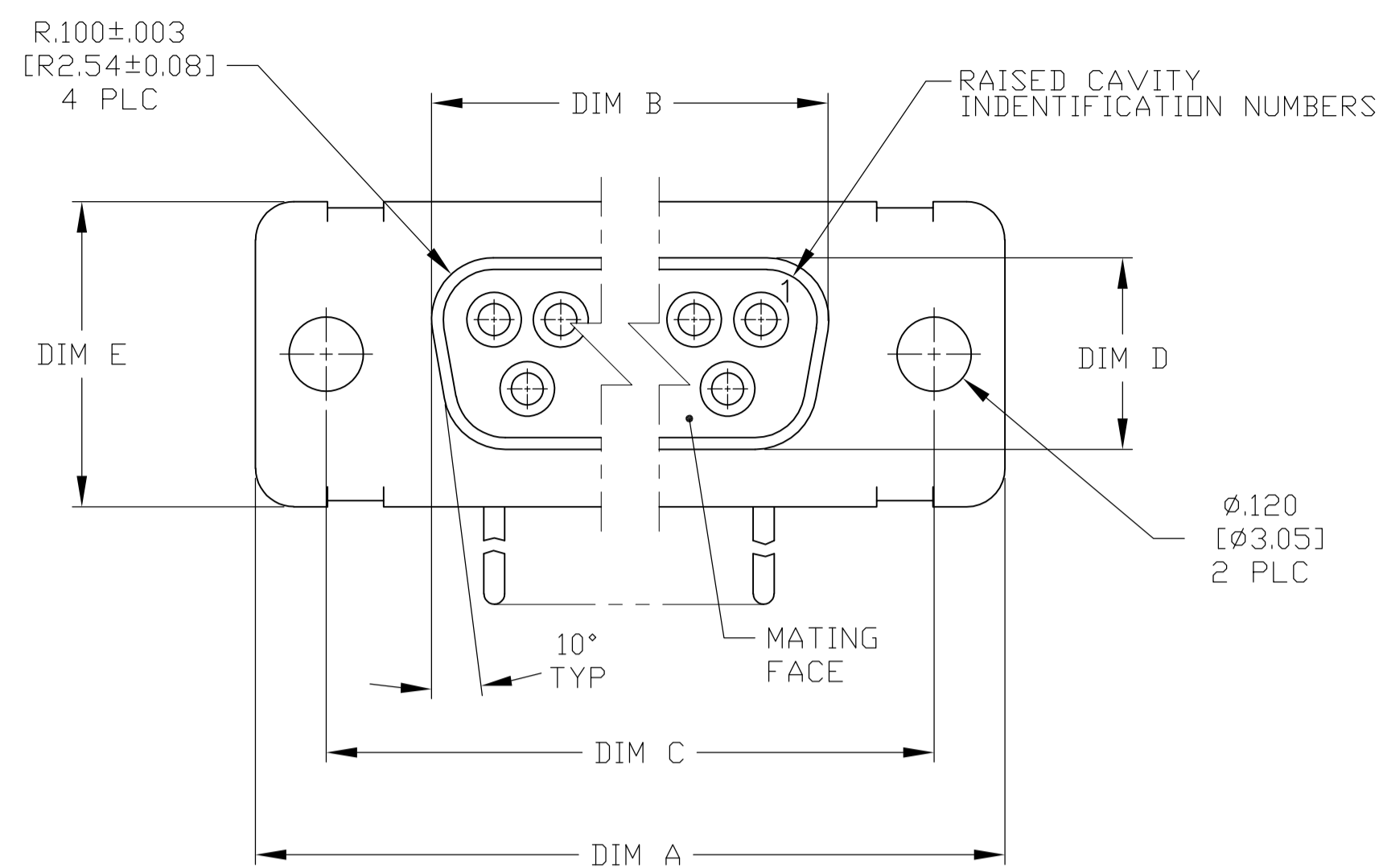

VIEW Z-Z
SHOWN WITH BRACKET REMOVED FOR CLARITY

CONTACT (QTY = NO. OF POSN)
MATL: BRASS PER ASTM-B-16, OR BERYLLIUM COPPER PER ASTM-B-194
FINISH: GOLD PER ASTM-B-488, TYPE II, GRADE C, CLASS 1.27 IN CONTACT MATING AREA, .000010 [0.0003] MIN THK GOLD PER ASTM-B-488 OVER .000050 [0.0013] MIN THK NICKEL PER SAE-AMS-QQ-N-290 ON CONTACT BODY

- SEE SHEET 2 FOR RECOMMENDED P.C. BOARD LAYOUT. TRUE POSITION TOLERANCE FOR P.C. BOARD LAYOUT IS .010 [0.25] AT MAX MATERIAL CONDITION. SUGGESTED BOARD THICKNESS IS .062 [1.57]
- THE CONNECTORS DESCRIBED IN THIS DOCUMENT MEET THE REQUIREMENTS OF MIL-C-24308 AND MATE WITH ANY PLUG CONNECTOR WITH SAME INSERT ARRANGEMENT.
- MARKED WITH .047 [1.19]-.062 [1.57] HIGH CHARACTERS. FAR SIDE REFERS TO THE WIDE SIDE OF THE KEYSTONE. NEAR SIDE REFERS TO THE NARROW SIDE OF THE KEYSTONE. IF THE REAR SHELL IS TOO SMALL FOR THE ENTIRE MILITARY PART NUMBER, MARKING SHALL BE LOCATED AS FOLLOWS:
 - "M24308" ON FRONT SHELL, FAR SIDE.
 - SLASH SHEET AND DASH NUMBER ON REAR SHELL, FAR SIDE.
 - "MFG'S NAME, LOGO OR TRADEMARK" AND DATE CODE ON FRONT SHELL, NEAR SIDE.
 - MFG'S PART NUMBER ON REAR SHELL, NEAR SIDE.
 IF THE FRONT SHELL IS TOO SMALL FOR "MFG'S NAME, LOGO OR TRADEMARK", MFG PART NO AND DATE CODE, MARKING SHALL BE SPLIT AS FOLLOWS:
 - MFG'S PART NUMBER ON REAR SHELL, NEAR SIDE.
 - "MFG'S NAME, LOGO OR TRADEMARK" AND DATE CODE ON FRONT SHELL, NEAR SIDE.
 - MILITARY PART NUMBER ON REAR SHELL, FAR SIDE.
- POINT OF ELECTRICAL ENGAGEMENT - AS MEASURED WITH A .0390-.0393 [0.991-0.998] DIA SQUARE ENDED PIN.
- SOLDER DIPPED PER J-STD-001 WITH Sn63 SOLDER PER J-STD-006 IN THE ENTIRE AREA OF DIMENSION SHOWN. (1757838-6 THRU -10 ONLY.)
- MEETS SOLDERABILITY PER MIL-STD-202 METHOD 208.

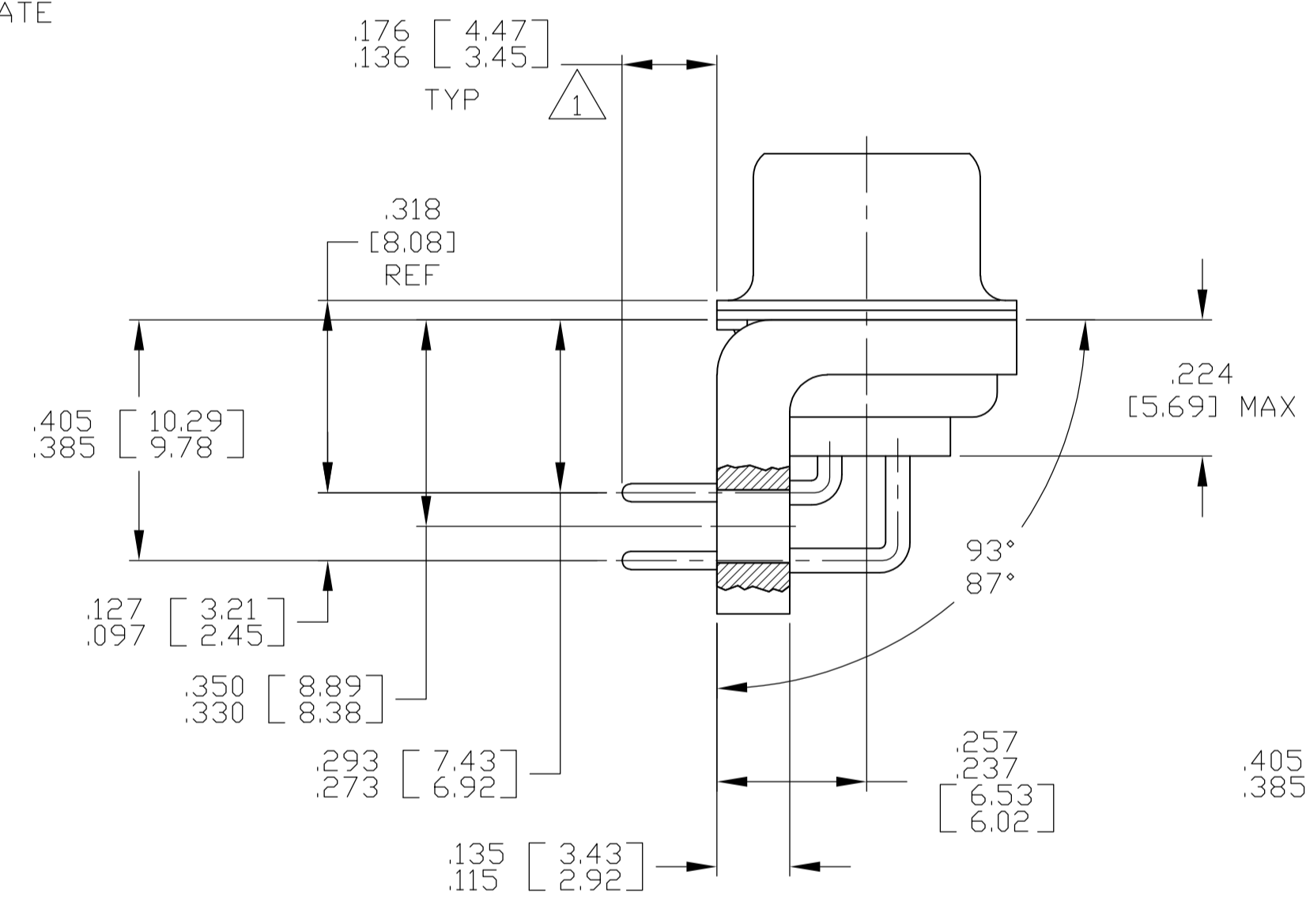
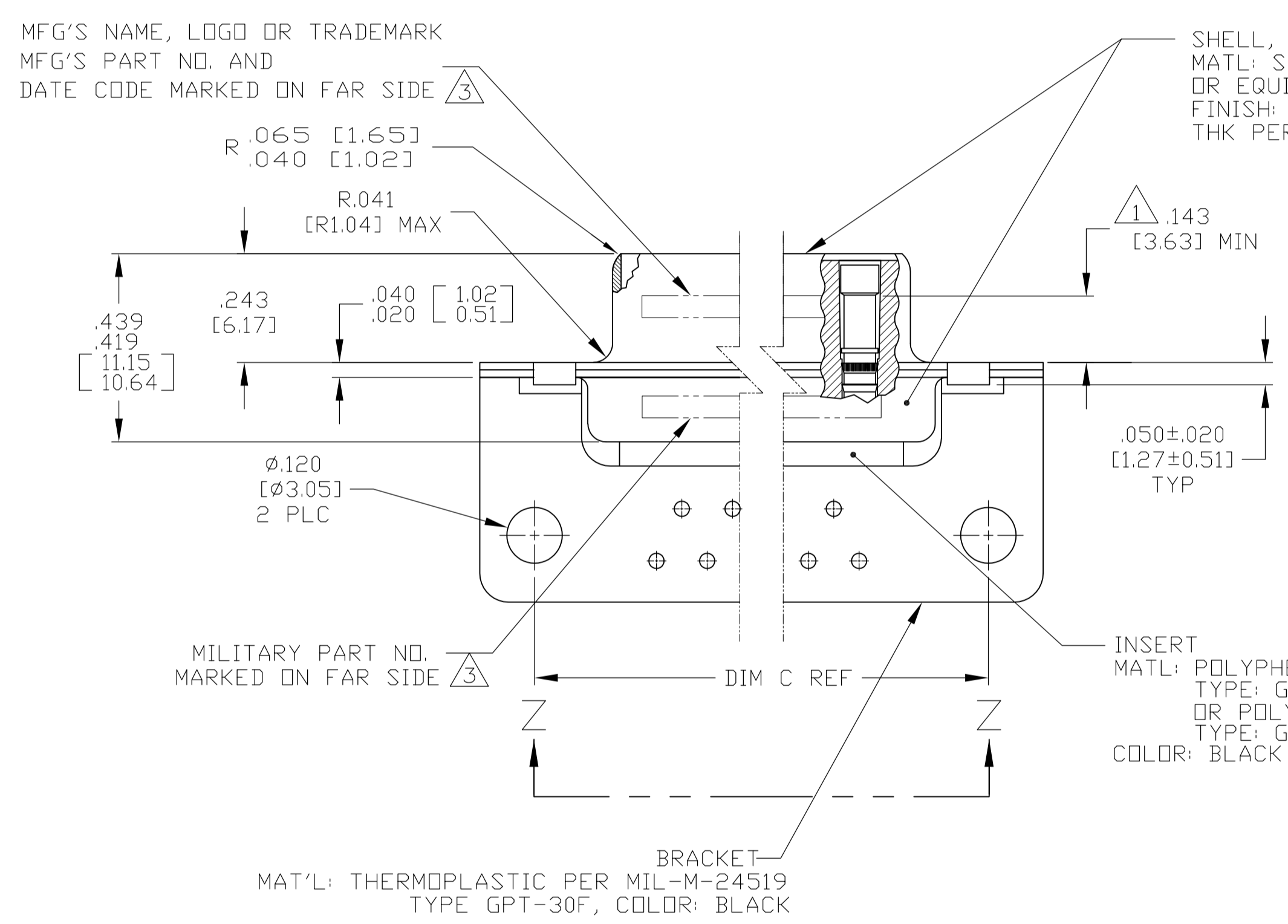

SHELL SIZES 1 THRU 4 CONTACT CONFIGURATION

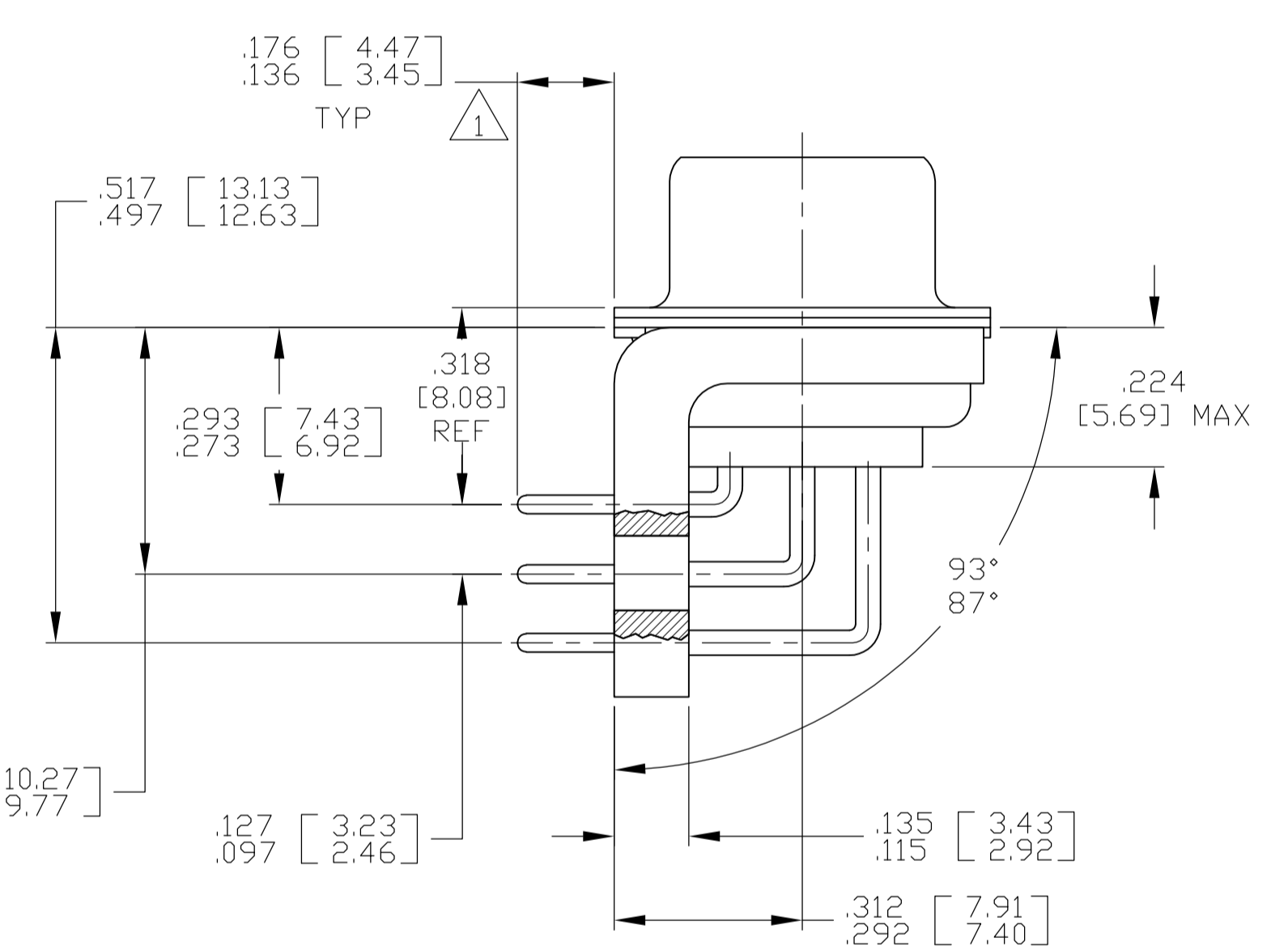

SHELL SIZE 5 CONTACT CONFIGURATION

.544 [13.82]	.524 [13.31]	2.188 [55.58]	2.168 [55.07]	.620 [15.75]	.590 [14.99]	.428 [10.87]	.418 [10.62]	2.411 [61.24]	2.401 [60.99]	2.069 [52.55]	2.059 [52.30]	2.650 [67.31]	2.620 [66.55]	MS18277-1	50	5	M24308/23-35Z	1757838-5	1-1757838-0
.432 [10.97]	.412 [10.46]	2.282 [57.96]	2.262 [57.45]	.509 [12.93]	.479 [12.17]	.316 [8.03]	.306 [7.77]	2.505 [63.63]	2.495 [63.37]	2.164 [54.97]	2.154 [54.71]	2.744 [69.70]	2.714 [68.94]	MS18276-1	37	4	M24308/23-34Z	1757838-4	1757838-9
.432 [10.97]	.412 [10.46]	1.635 [41.53]	1.615 [41.02]	.509 [12.93]	.479 [12.17]	.316 [8.03]	.306 [7.77]	1.857 [47.17]	1.847 [46.91]	1.516 [38.51]	1.506 [38.25]	2.103 [53.42]	2.073 [52.65]	MS18275-1	25	3	M24308/23-33Z	1757838-3	1757838-8
.432 [10.97]	.412 [10.46]	1.093 [27.76]	1.073 [27.25]	.509 [12.93]	.479 [12.17]	.316 [8.03]	.306 [7.77]	1.317 [33.45]	1.307 [33.20]	.976 [24.79]	.966 [24.54]	1.556 [39.52]	1.526 [38.76]	MS18274-1	15	2	M24308/23-32Z	1757838-2	1757838-7
.432 [10.97]	.412 [10.46]	.769 [19.53]	.749 [19.02]	.509 [12.93]	.479 [12.17]	.316 [8.03]	.306 [7.77]	.989 [25.12]	.979 [24.87]	.648 [16.46]	.638 [16.21]	1.228 [31.19]	1.198 [30.43]	MS18273-1	9	1	M24308/23-31Z	1757838-1	1757838-6
.544 [13.82]	.524 [13.31]	2.188 [55.58]	2.168 [55.07]	.620 [15.75]	.590 [14.99]	.428 [10.87]	.418 [10.62]	2.411 [61.24]	2.401 [60.99]	2.069 [52.55]	2.059 [52.30]	2.650 [67.31]	2.620 [66.55]	MS18277-1	50	5	M24308/23-35Z	1757838-5	1757838-5
.432 [10.97]	.412 [10.46]	2.282 [57.96]	2.262 [57.45]	.509 [12.93]	.479 [12.17]	.316 [8.03]	.306 [7.77]	2.505 [63.63]	2.495 [63.37]	2.164 [54.97]	2.154 [54.71]	2.744 [69.70]	2.714 [68.94]	MS18276-1	37	4	M24308/23-34Z	1757838-4	1757838-4
.432 [10.97]	.412 [10.46]	1.635 [41.53]	1.615 [41.02]	.509 [12.93]	.479 [12.17]	.316 [8.03]	.306 [7.77]	1.857 [47.17]	1.847 [46.91]	1.516 [38.51]	1.506 [38.25]	2.103 [53.42]	2.073 [52.65]	MS18275-1	25	3	M24308/23-33Z	1757838-3	1757838-3
.432 [10.97]	.412 [10.46]	1.093 [27.76]	1.073 [27.25]	.509 [12.93]	.479 [12.17]	.316 [8.03]	.306 [7.77]	1.317 [33.45]	1.307 [33.20]	.976 [24.79]	.966 [24.54]	1.556 [39.52]	1.526 [38.76]	MS18274-1	15	2	M24308/23-32Z	1757838-2	1757838-2
.432 [10.97]	.412 [10.46]	.769 [19.53]	.749 [19.02]	.509 [12.93]	.479 [12.17]	.316 [8.03]	.306 [7.77]	.989 [25.12]	.979 [24.87]	.648 [16.46]	.638 [16.21]	1.228 [31.19]	1.198 [30.43]	MS18273-1	9	1	M24308/23-31Z	1757838-1	1757838-1

DIM J	DIM H	DIM E	DIM D	DIM C	DIM B	DIM A	INSERT ARRANGEMENT	NO OF POS	SHELL SIZE	MILITARY P/N ON CONNECTOR	MFG P/N MARKED ON CONNECTOR	MFG PART NO.
-------	-------	-------	-------	-------	-------	-------	--------------------	-----------	------------	---------------------------	-----------------------------	--------------

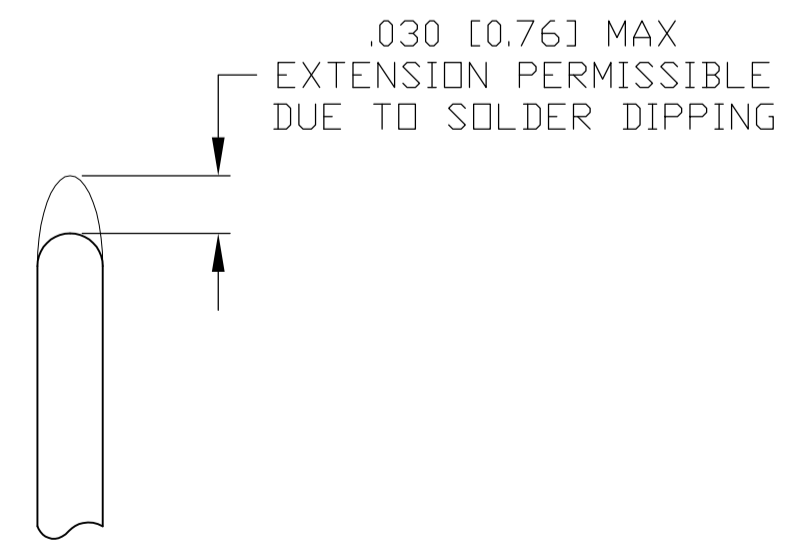

DETAIL K
SCALE 10:1
FOR 1757838-6 THRU -10 ONLY

THIS DRAWING IS A CONTROLLED DOCUMENT.

DMN: C.C. THOMAS 3-22-06
CHK: D. MILLER 3-27-06
APPV: D. MILLER 3-27-06

RECEPTACLE ASSEMBLY, AMPLITE, RT ANGLE, SERIES 109, SIZE 1 THRU 5

STE TE Connectivity

SIZE: A1 CASE CODE: 00779 DRAWING NO: 1757838

SCALE: 4:1 SHEET: 1 OF 2 REV: C

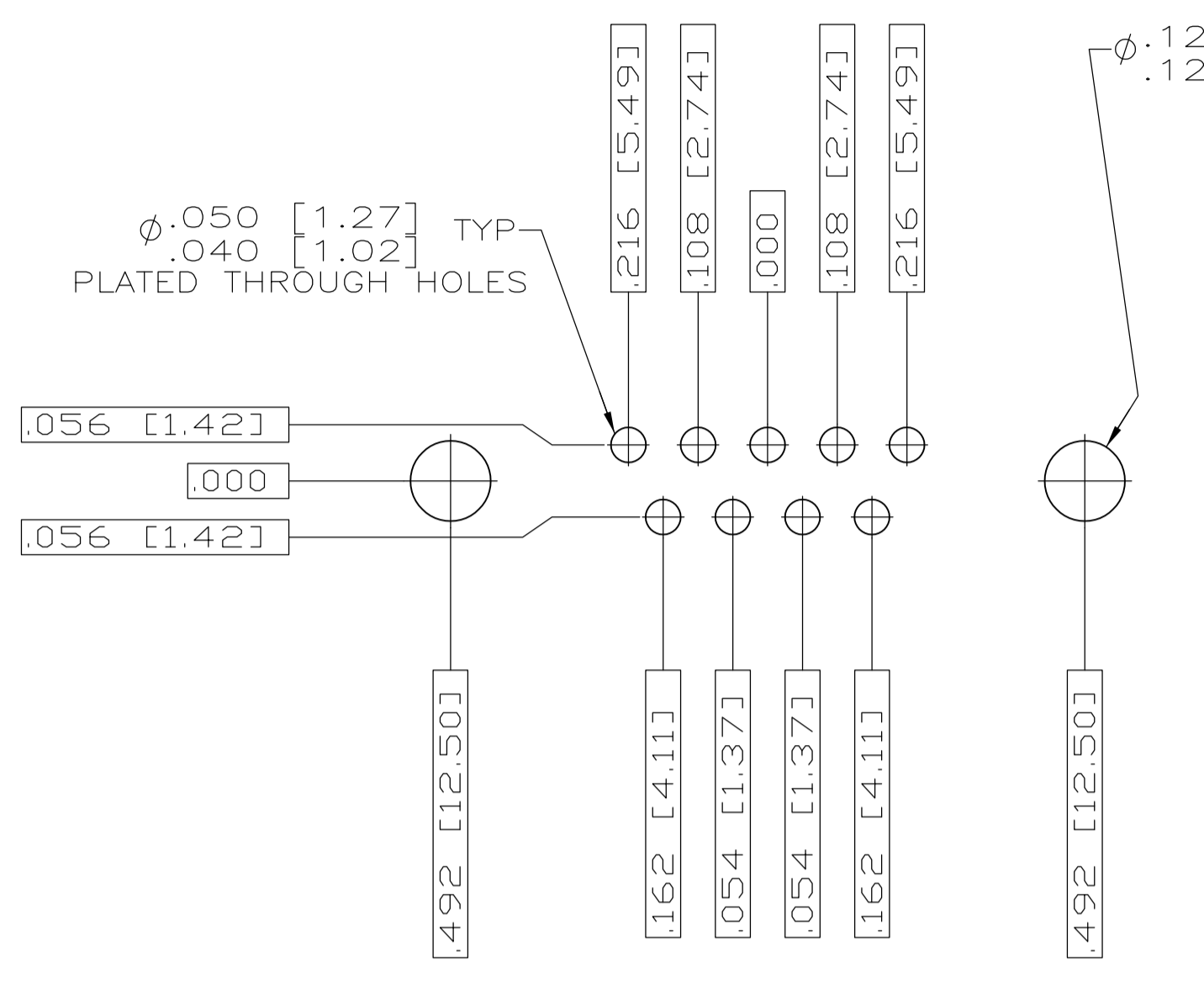

RECOMMENDED P.C. BOARD LAYOUT
 SHELL SIZE 1 (9 POSITION) \triangle

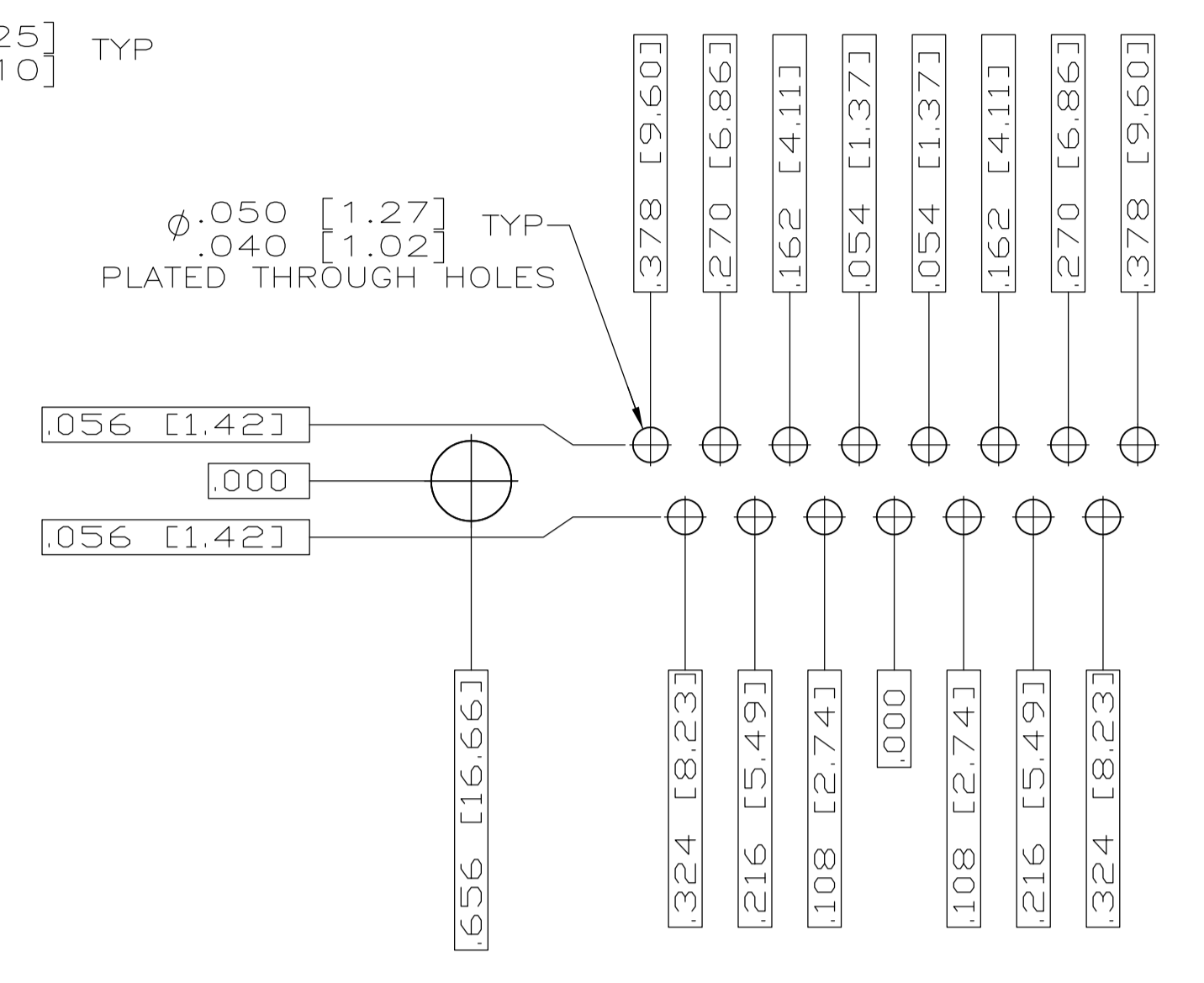

RECOMMENDED P.C. BOARD LAYOUT
 SHELL SIZE 2 (15 POSITION) \triangle

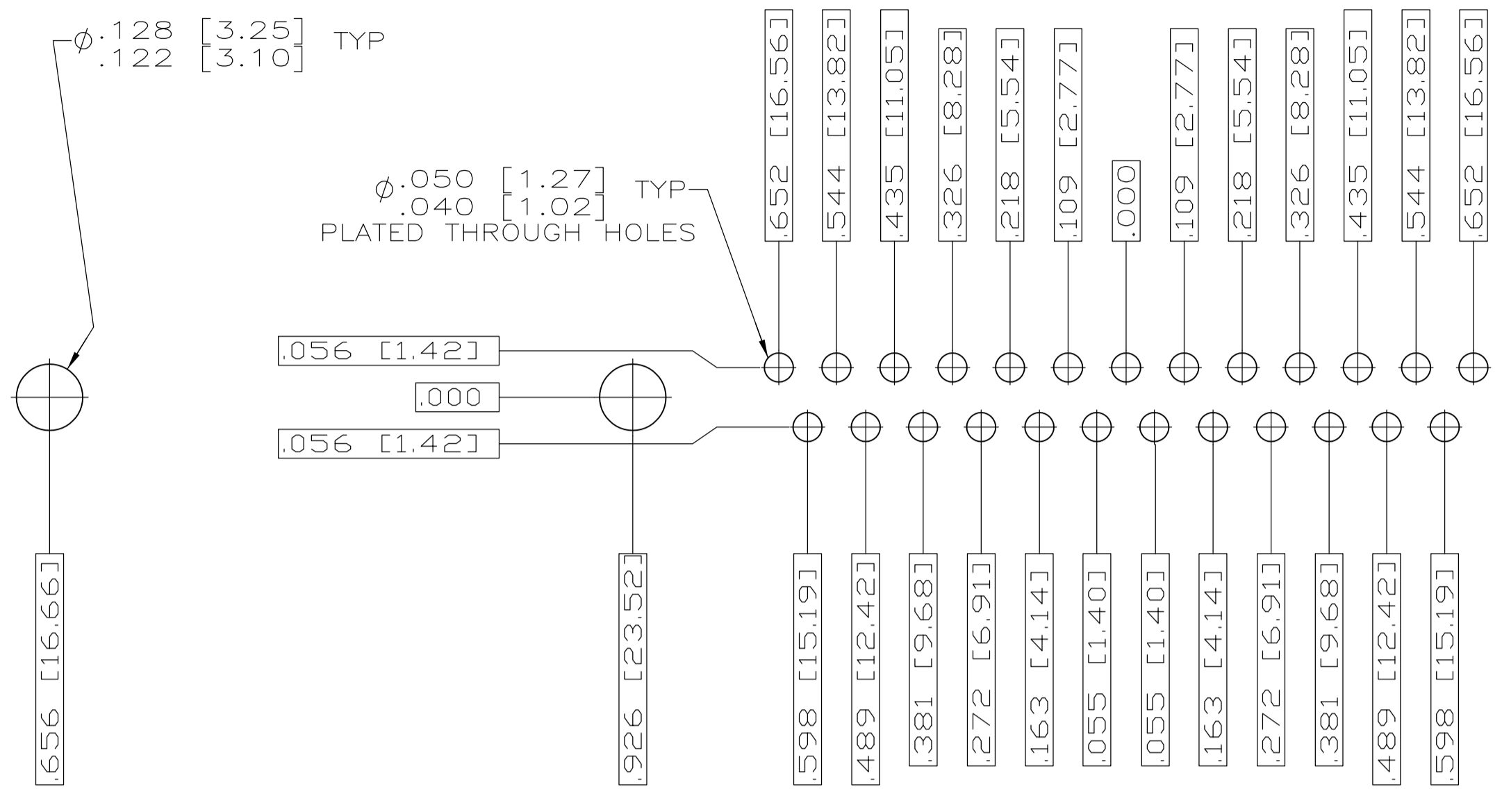

RECOMMENDED P.C. BOARD LAYOUT
 SHELL SIZE 3 (25 POSITION) \triangle

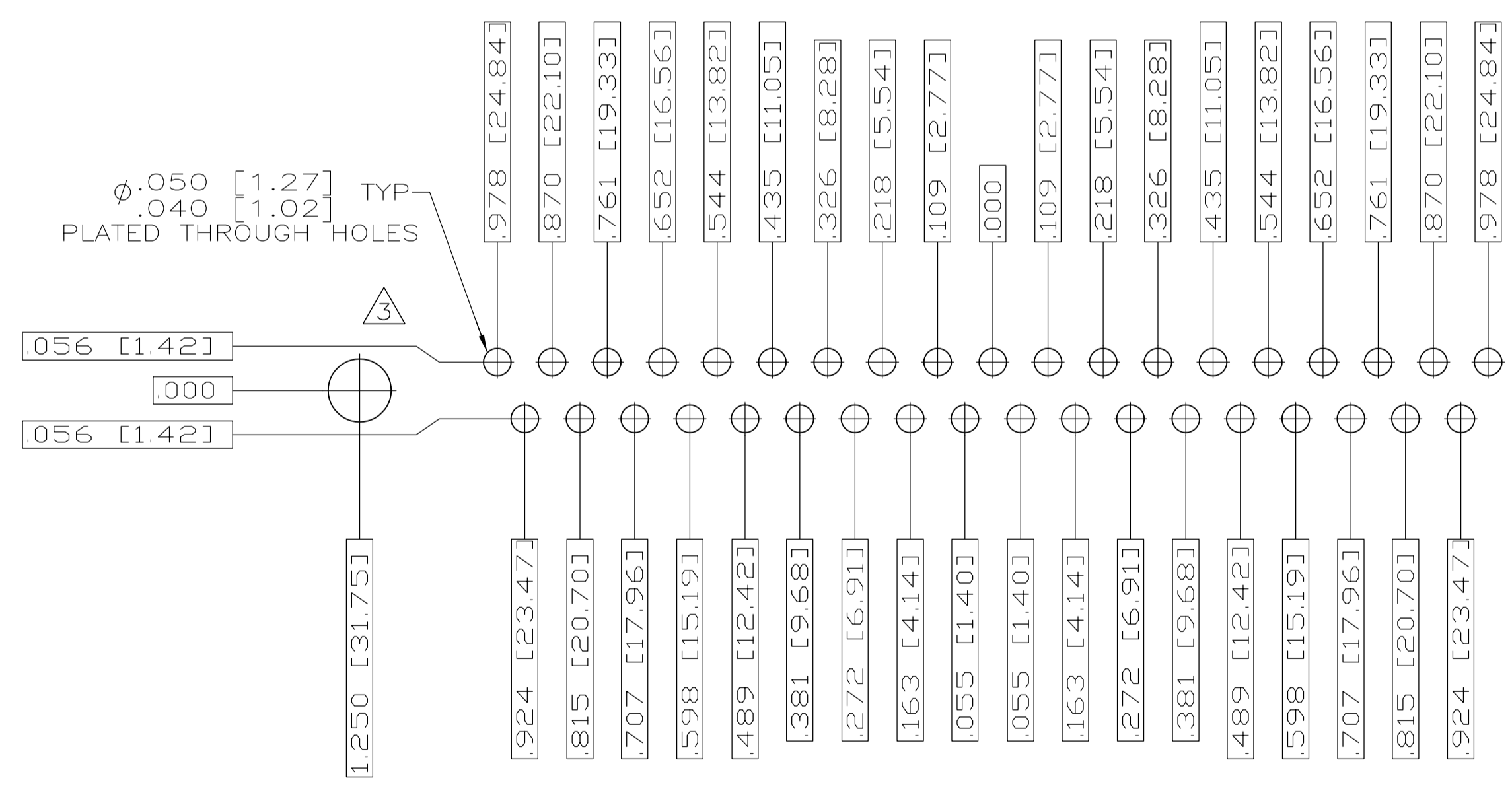

RECOMMENDED P.C. BOARD LAYOUT
 SHELL SIZE 4 (37 POSITION) \triangle

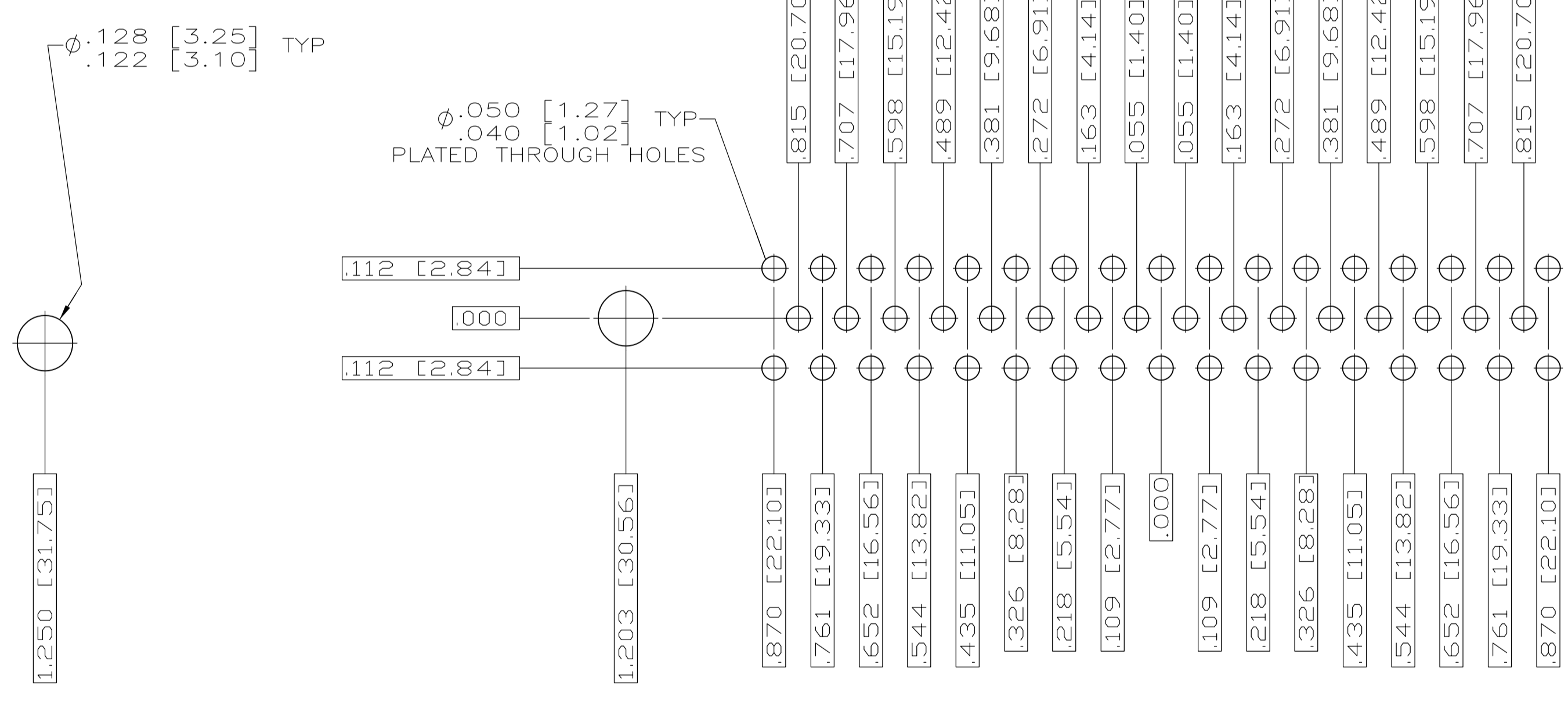

RECOMMENDED P.C. BOARD LAYOUT
 SHELL SIZE 5 (50 POSITION) \triangle

THIS DRAWING IS A CONTROLLED DOCUMENT.		OWN J.C. THOMAS	3-22-06	TE Connectivity
DIMENSIONS: INCHES		CHK D. MILLER	3-27-06	
	TOLERANCES UNLESS OTHERWISE SPECIFIED:	APP'D D. MILLER	3-27-06	NAME RECEPTACLE ASSEMBLY, AMPULMITE, RT ANGLE, SERIES 109, SIZE 1 THRU 5
	0 PLC	± -	PRODUCT SPEC	
	1 PLC	± -	APPLICATION SPEC	
	2 PLC	± -		
MATERIAL SEE CALLOUTS	FINISH SEE CALLOUTS	WEIGHT	-	SIZE A1
CUSTOMER DRAWING			SCALE 4:1	SHEET 2 OF 2 REV C

单击下面可查看定价，库存，交付和生命周期等信息

[>>TE Connectivity\(泰科\)](#)