

THIS DRAWING IS UNPUBLISHED. RELEASED FOR PUBLICATION
 © COPYRIGHT - By - ALL RIGHTS RESERVED.

LOC	DIST	REVISIONS			
P	LTR	DESCRIPTION	DATE	DWN	APVD
AJ	16	D1	ECR-12-005726	27MAR12	RK MY

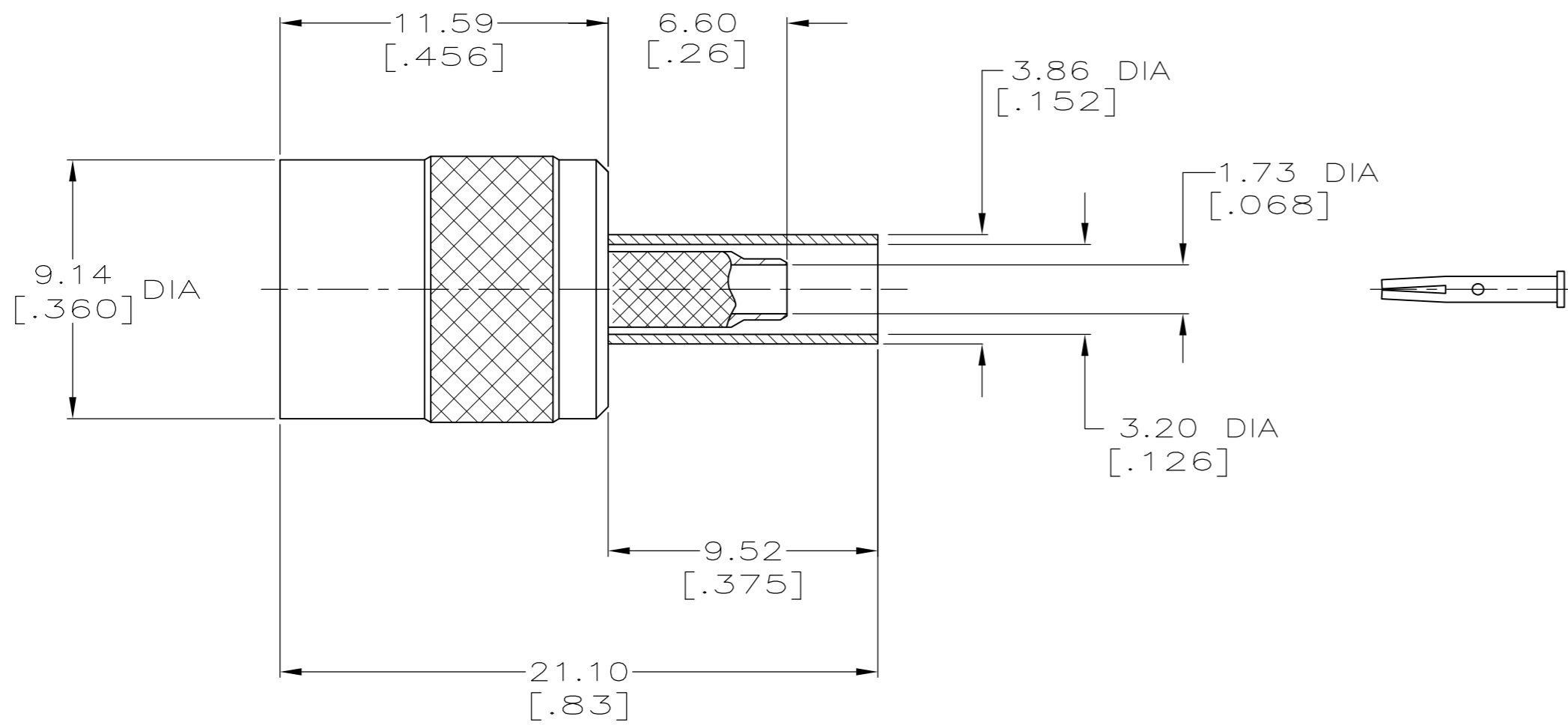

1. MATERIALS:
 BODIES...BRASS PER QQ-B-626
 INNER AND OUTER CONTACTS...
 BERYLLIUM COPPER PER QQ-C-576
 DIELECTRIC...PTFE PER ASTM D1710
 FERRULE...ANNEALED COPPER PER QQ-C-576
2. FINISH:
 CENTER CONTACT...GOLD PER MIL-G-45204
 OTHER METAL PARTS...NICKEL PER QQ-N-290
3. FINISH:
 CENTER AND OUTER CONTACT...GOLD PER MIL-G-45204
 OTHER METAL PARTS...NICKEL PER QQ-N-290

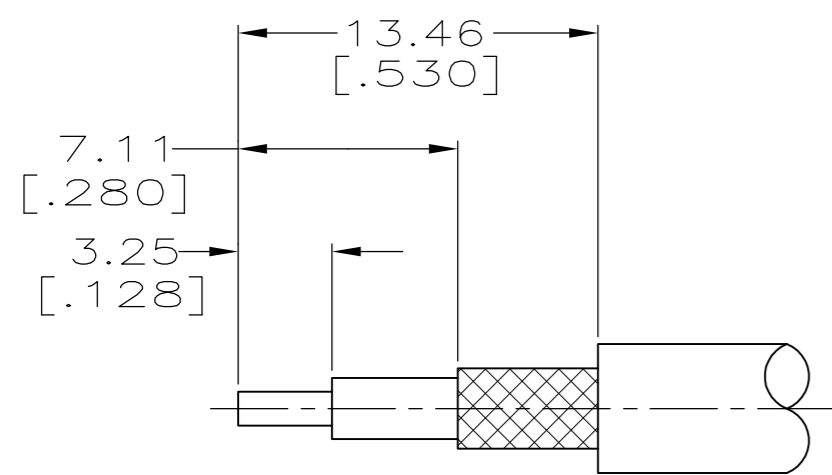

RECOMMENDED STRIP LENGTHS
 SCALE NTS

B	58483-1	.128	HX4-1637	4	K699	2	RG 179,187	414618-2
B	58483-1	.128	HX4-1637	4	K699	3	RG 179,187	414618-1
POSITION LETTER	TE DIE SET	HEX SIZE	DANIELS DIE SET	SELECTOR NUMBER	DANIELS POSITIONER	NOTES	CABLE	PART NUMBER
TE PRO-CRIMPER FOR BRAID CRIMP		M 22520/5-01 FOR BRAID CRIMP		M 22520/2-01 FOR CONTACT CRIMP				
TOOLING INFORMATION								

THIS DRAWING IS A CONTROLLED DOCUMENT.		DWN B. WERNER 13/JUL/93	TE Connectivity	
DIMENSIONS: mm [INCHES]		CHK J. MCLEOD 13/JUL/93		
TOLERANCES UNLESS OTHERWISE SPECIFIED:		APVD J. MCLEOD 13/JUL/93	NAME 75 OHM SMB PLUG	
0 PLC ± - 1 PLC ± - 2 PLC ± .25 [.010] 3 PLC ± .13 [.005] 4 PLC ± - ANGLES ± -		PRODUCT SPEC -	SIZE A2	
MATERIAL SEE NOTES		FINISH SEE NOTES	APPLICATION SPEC -	CAGE CODE 00779
		WEIGHT -	DRAWING NO C-414618	RESTRICTED TO -
CUSTOMER DRAWING			SCALE 5:1	SHEET 1 OF 1
			REV D1	

CUSTOMER DRAWING

单击下面可查看定价，库存，交付和生命周期等信息

[>>TE Connectivity\(泰科\)](#)