

- ① ZINC PER QQ-Z-363.
- ② POLYMETHYLPENTENE, GENERAL PURPOSE.
- ③ BERYLLIUM COPPER PER QQ-C-530.
- ④ BRASS PER ASTM-B-453.
- ⑤ NICKEL PLATE PER QQ-N-290,
3.81 μm [.000150] MINIMUM THICK.
- ⑥ TIN PLATE PER ASTM-B-545,
3.81 μm [.000150] MINIMUM THICK.
- ⑦ GOLD PLATE PER ASTM-B-488,
0.76 μm [.000030] MINIMUM THICK.
- 8. SEE INSTRUCTION SHEET 408-2769.

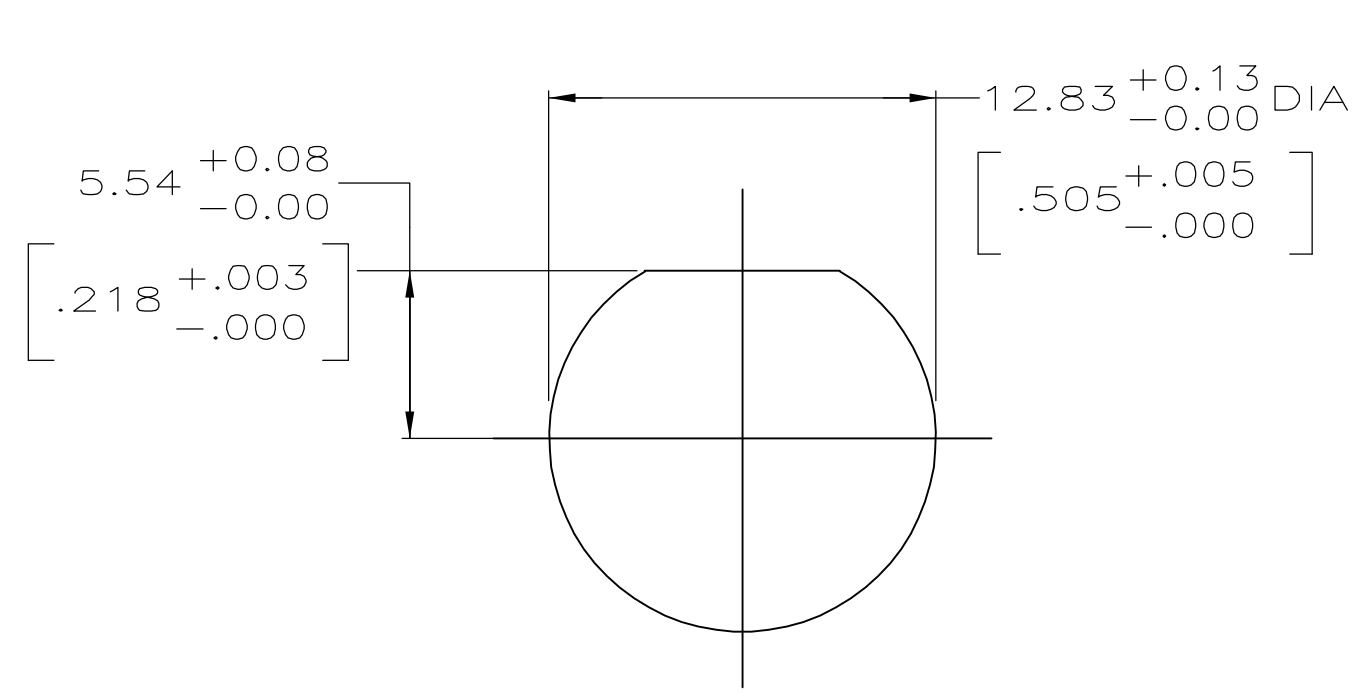

RECOMMENDED PANEL CUTOUT

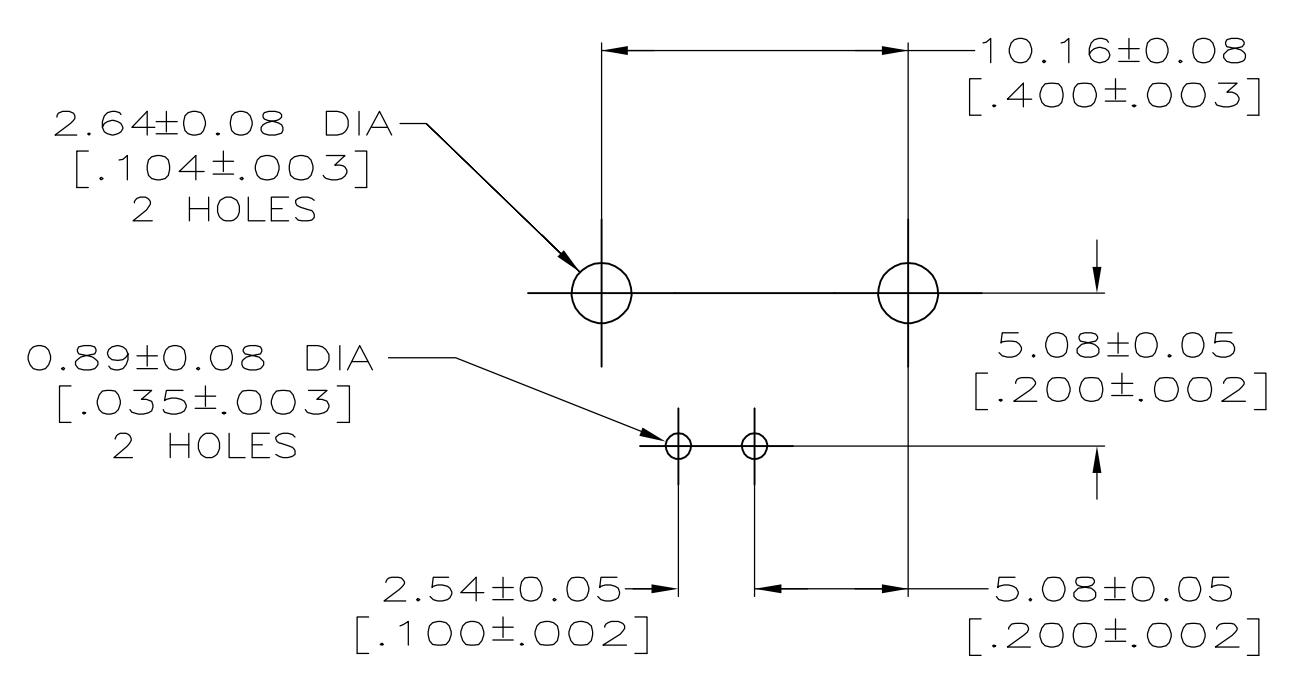

PCB CONFIGURATION

6274072-1
PART NUMBER

THIS DRAWING IS A CONTROLLED DOCUMENT.		DWN J. ALCORTA - 27APR2005		Tyco Electronics Corporation Harrisburg, PA 17105-3608
DIMENSIONS: mm [INCHES]		CHK J. HAVENER - 27APR2005		NAME J. LIPPERT - 27APR2005
TOLERANCES UNLESS OTHERWISE SPECIFIED:		PRODUCT SPEC		JACK, RIGHT ANGLE, 75 OHM, LOW PROFILE, PCB, BNC
0. PLC ± - 1. PLC ± - 2. PLC ± 0.20 [.008] 3. PLC ± - 4. PLC ± - ANGLES ± -		APPLICATION SPEC		SIZE CAGE CODE DRAWING NO
MATERIAL SEE NOTES 1 - 5		WEIGHT		A1 00779 ©=6274072
FINISH SEE NOTES 5 - 7		CUSTOMER DRAWING		SCALE 4:1 SHEET 1 OF 1 REV A

单击下面可查看定价，库存，交付和生命周期等信息

[>>TE Connectivity\(泰科\)](#)