

MALCO PART NO.
010-0150-0000

ASTRO PRODUCTS PART NO.
A 826-1

GAGE HANDLE
GO-.0160 RED
NO GO-.0185

REVISIONS					
ZONE	LTR	ECN.	DESCRIPTION	DATE	APPROVED
	G	31762	REVISED & REDRAWN.	11/21/88	<i>MD</i>
	H	34353	ASTRO PROD. P/N WAS: 826 D	10/21/92	<i>ES</i>
	H1	43876	Update per ECO-09-008101	3/31/09	JDM
	H2	43876	Update per ECO-09-011 011	5/06/09	JDM

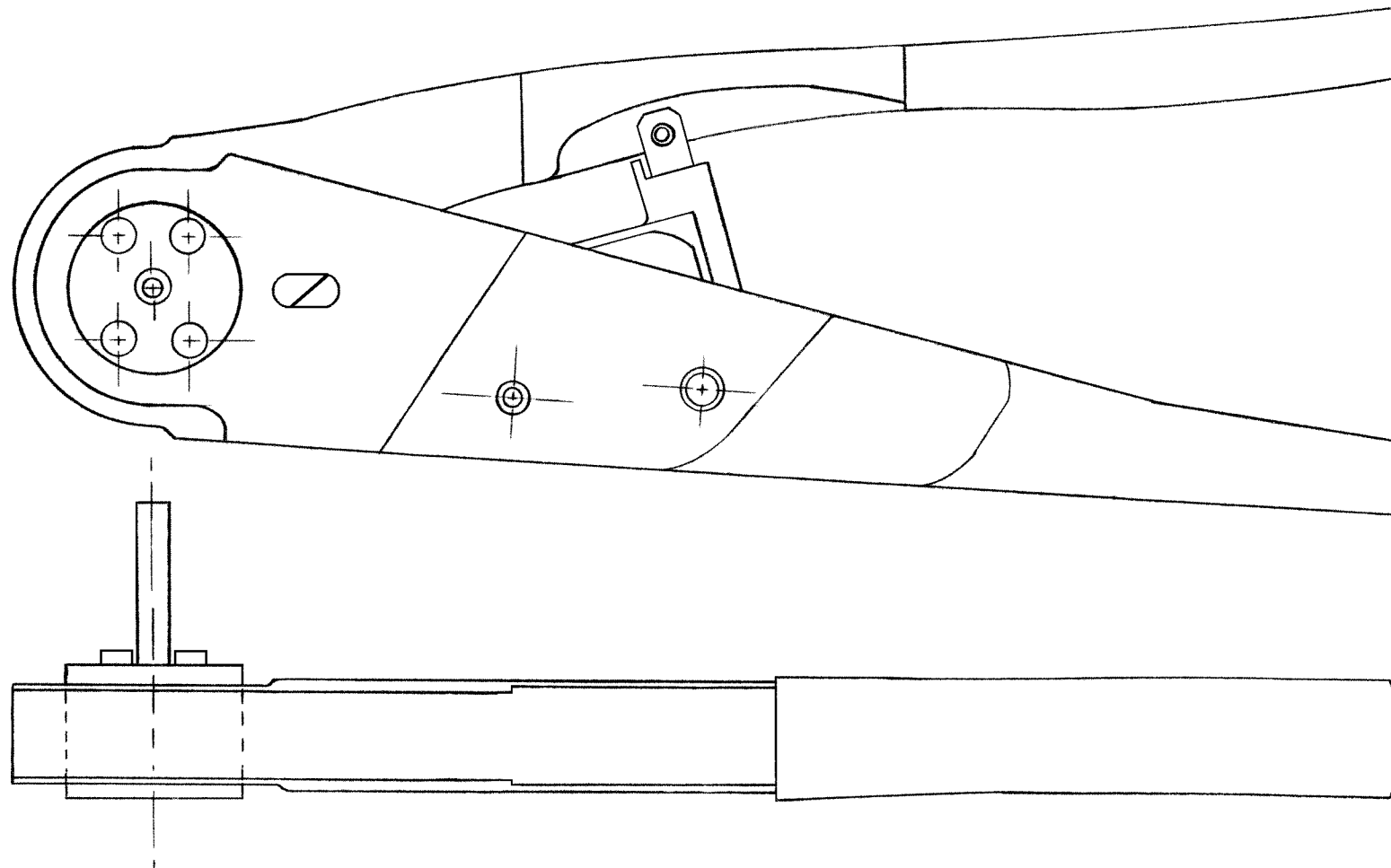
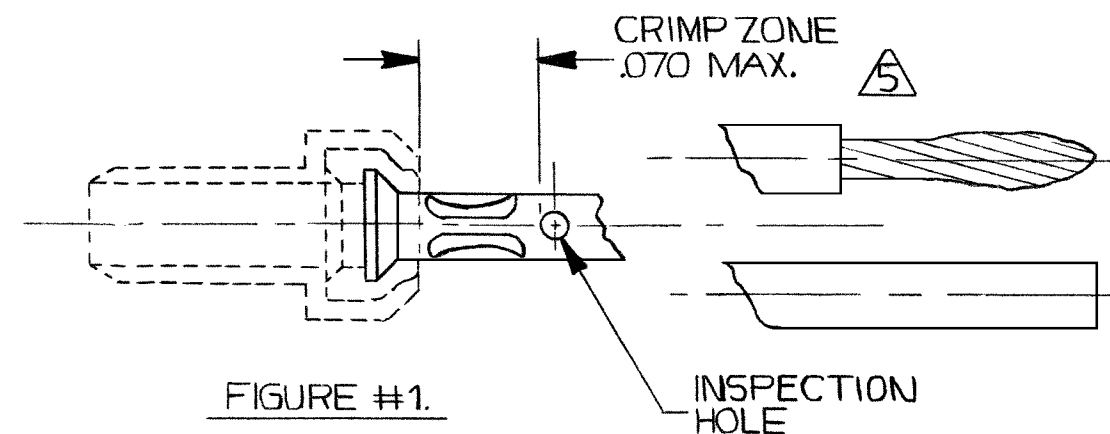



FIGURE #1 DEPICTS:

- PIN CONTACT ASSY. 096-0525-0001
- CONTACT FERRULE
SUB ASSY: 014-1002-0001
- SOCKET CONTACT: 014-0009-0002
- CONTACT FERRULE
SUB ASSY: 014-1009-0001



NOTES: UNLESS OTHERWISE SPECIFIED

- FOR USE ON LEPRACON CONTACTS 014-1002-0001, 014-1009-0001, 014-1058-0001, 014-1063-0001, 014-1180-0001 & 096-0525-0029
- AS SUPPLIED BY ASTRO TOOL, BEAVERTON, ORE.
- MAX. ALLOWABLE CONTACT T.I.R. .005 AFTER CRIMPING
- AFTER CRIMP TENSILE REQMT'S - 7/38 AWG CU WELD ANNEALED MUST HOLD 4LBS. MIN.
- ENTIRE CRIMP MUST OCCUR IN THE DESIGNATED ZONE (SEE FIG 1) OF EITHER SPECIFIED CONTACT

		UNLESS OTHERWISE SPECIFIED DIMENSIONS ARE IN INCHES TOLERANCES ARE: FRACTIONS DECIMALS ANGLES ± .XX ± ± .XXX ±		CONTRACT NO.		 MALCO A MICRODOT COMPANY, INC. 220 PASADENA AVE., SO. PASADENA, CALIF. 91030		PROD. CODE 936	
		MATERIAL		APPROVALS				DATE	
		FINISH		DRAWN <i>Marcus Sanders</i>		21 Nov 88		CRIMP TOOL	
		NEXT ASSY		USED ON		CHECKED <i>MD</i>		LEPRA CON MINIATURE COAX	
		APPLICATION		DO NOT SCALE DRAWING		PR. ENG. <i>Robert</i>		MICRODOT P/N 010-0150-0000	
						APPROVED		DRAWING NO.	
						These drawings and specifications are the property of Microdot Inc., are issued in strict confidence and shall not be divulged, be reproduced or copied, or used as the basis for the manufacture or sale of any article without written permission of Microdot Inc.		SIZE	
						SCALE		CODE IDENT NO.	
						B		98278	
								DRAWING NO.	
								4-1532136-0	
								SHEET OF	

单击下面可查看定价，库存，交付和生命周期等信息

[>>TE Connectivity\(泰科\)](#)