

THIS DRAWING IS UNPUBLISHED. RELEASED FOR PUBLICATION

© COPYRIGHT BY TYCO ELECTRONICS CORPORATION. ALL RIGHTS RESERVED.

LOC	DIST	REVISIONS			
P	LTR	DESCRIPTION	DATE	DWN	APVD
G	50	B	REVISED PER ECR-10-006099	06JUL10	HMR PD

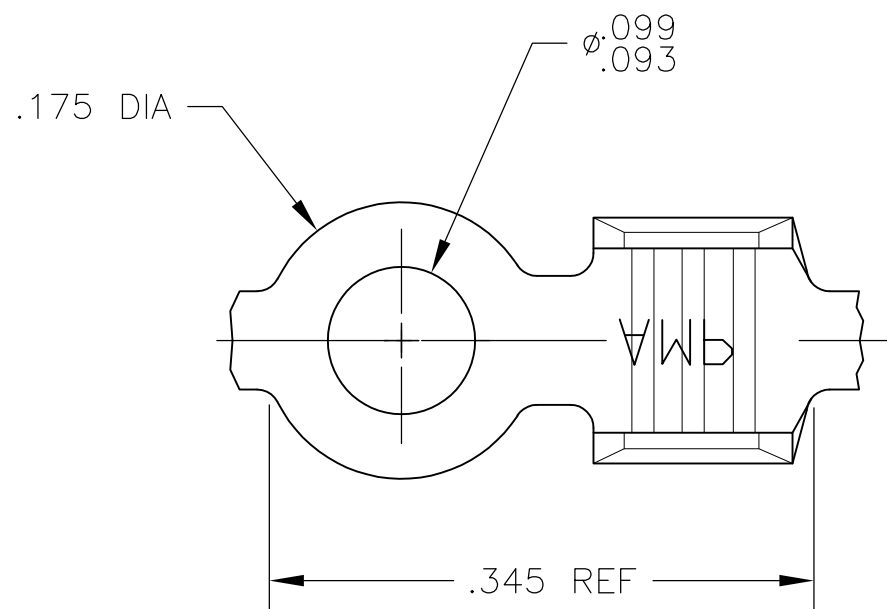

1. CONTINUOUS STRIP ON REELS
2. WIRE SIZE IS #18-#14 AWG

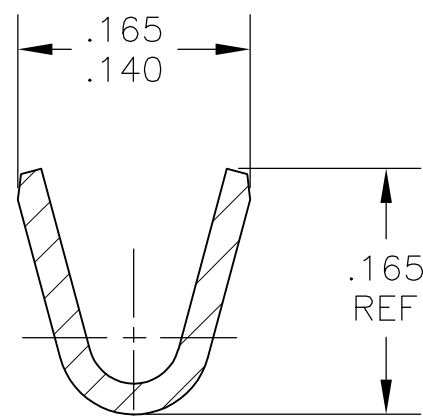
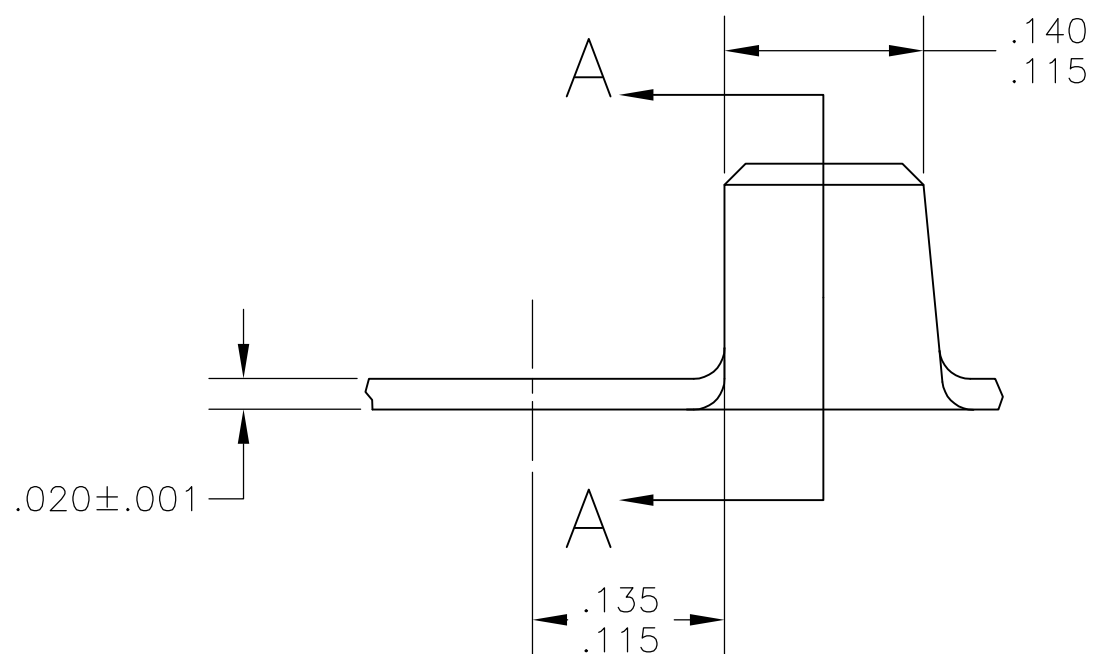

OBSOLETE	—	082 BRASS	41499-2
OBSOLETE	TIN	TC COPPER	41499-1
	TIN	082 BRASS	41499
	FINISH	MATERIAL	PART NO

THIS DRAWING IS A CONTROLLED DOCUMENT.		DWN jr_ruth 17FEB06	Tyco Electronics Corporation Harrisburg, PA 17105-3608	
DIMENSIONS: INCHES	TOLERANCES UNLESS OTHERWISE SPECIFIED:	CHK D DECKER 17FEB06	NAME	
	0 PLC ± - 1 PLC ± - 2 PLC ± - 3 PLC ± .010 4 PLC ± - ANGLES ± 5'	APVD D DECKER 17FEB06	RING	
MATERIAL SEE TABLE	FINISH SEE TABLE	PRODUCT SPEC —	APPLICATION SPEC —	RESTRICTED TO —
		WEIGHT —	SIZE A3	CAGE CODE 00779
			DRAWING NO C-41499	
CUSTOMER DRAWING			SCALE 8:1	SHEET 1 OF 1
			REV B	

单击下面可查看定价，库存，交付和生命周期等信息

[>>TE Connectivity\(泰科\)](#)