

REVISIONS					
P	LTR	DESCRIPTION	DATE	DWN	APVD
B		REV PER ECO 20-008137	6-15-20	CT	RL

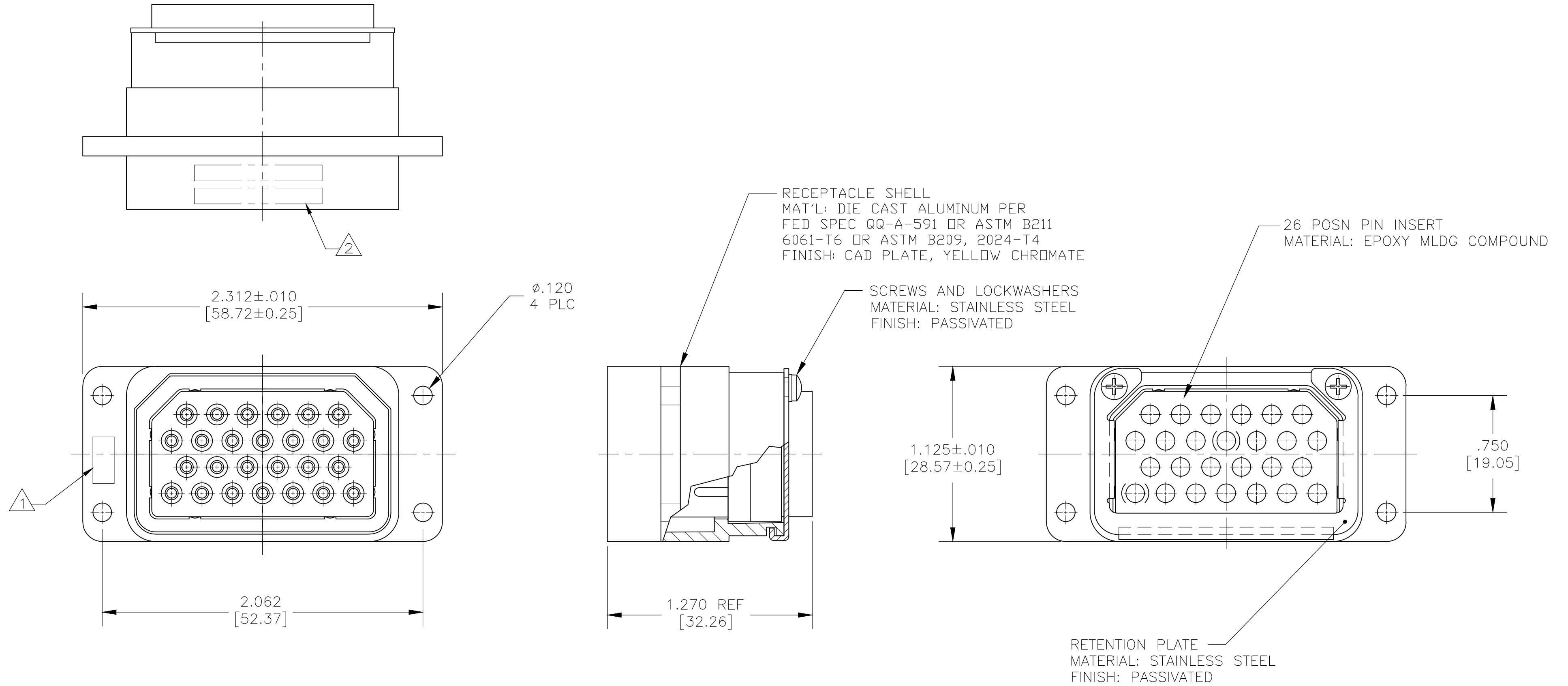

- 1 AMP MARKED ON THIS SURFACE
- 2 TE PART NUMBER AND DATE CODE AND DESCRIPTIVE NUMBER MARKED ON THIS SURFACE

1218203-1
 PART NUMBER

THIS DRAWING IS A CONTROLLED DOCUMENT.		DWN C.C.THOMAS 3-114	TE Connectivity RECEPTACLE ASSEMBLY, ARINC 404, RMA1R26P-00 (201)		
DIMENSIONS: INCHES		CHK D. EABY 3-13-14			
TOLERANCES UNLESS OTHERWISE SPECIFIED:		APVD D. EABY 3-13-14	NAME		
0 PLC ± - 1 PLC ± - 2 PLC ± - 3 PLC ± .005 [0.13] 4 PLC ± - ANGLES ± -		PRODUCT SPEC	SIZE		
MATERIAL SEE CALLOUTS		FINISH SEE CALLOUTS	APPLICATION SPEC	CAGE CODE A2 00779	DRAWING NO C=1218203
		WEIGHT 0.000000	RESTRICTED TO	SCALE 2:1	SHEET 1 of 1
		CUSTOMER DRAWING	REV B		

单击下面可查看定价，库存，交付和生命周期等信息

[>>TE Connectivity\(泰科\)](#)