

4

3

2

1

THIS DRAWING IS UNPUBLISHED. RELEASED FOR PUBLICATION 20
COPYRIGHT 20 ALL RIGHTS RESERVED.

LOC	DIST	REVISIONS			
P	LTR	DESCRIPTION	DATE	DWN	APVD
		A	INITIAL RELEASE	07FEB2020	K.G W.H

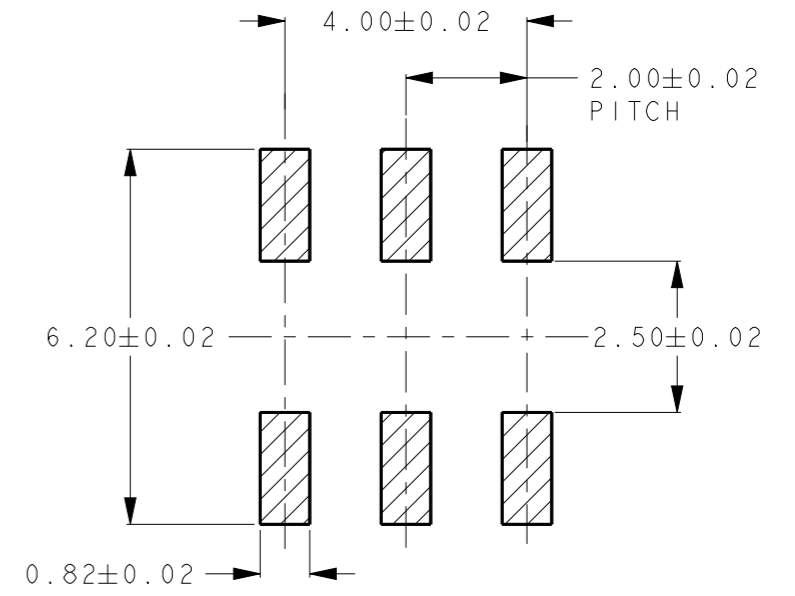
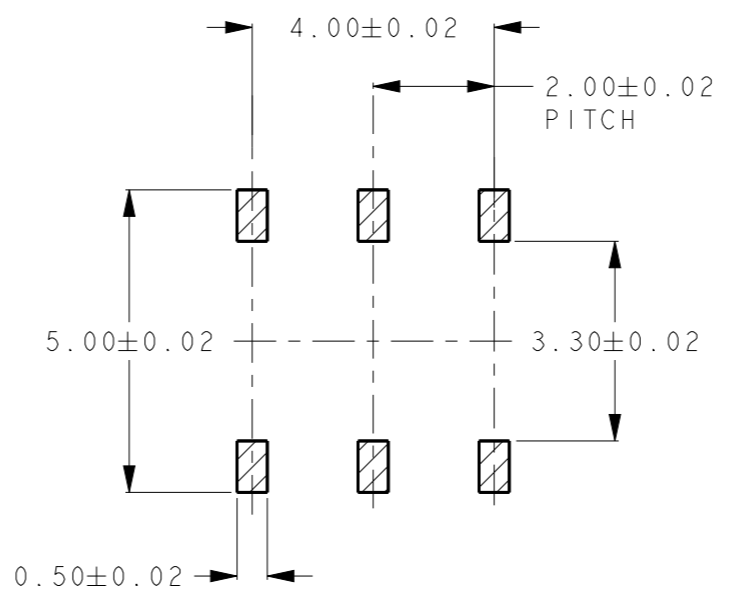
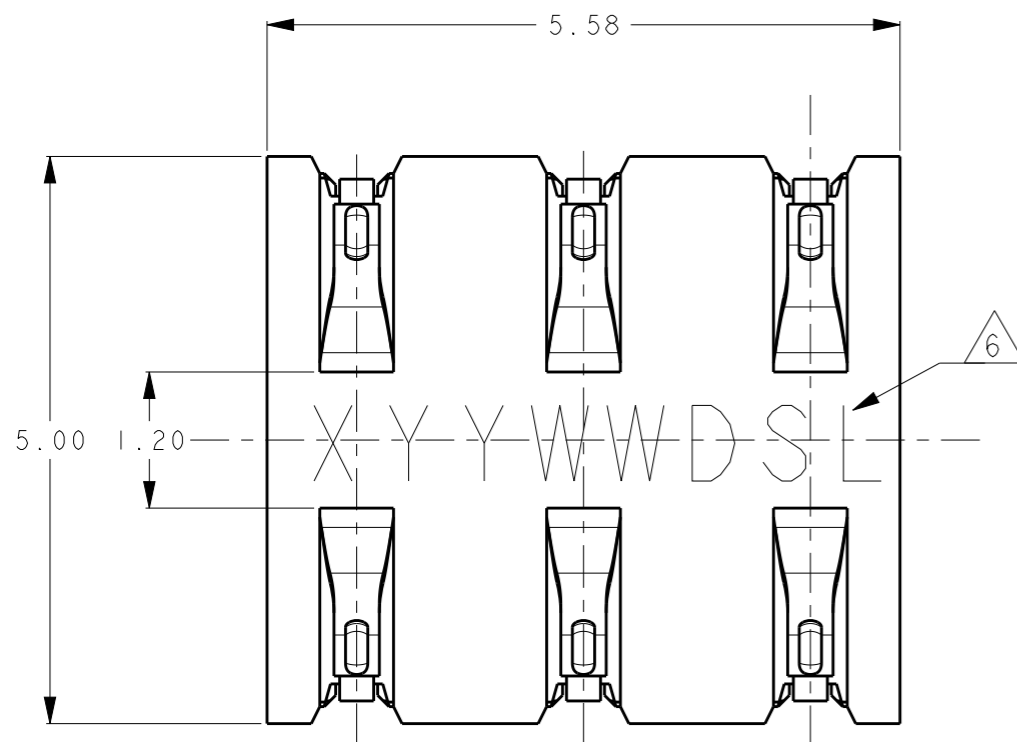

SCALE 8:1
RECOMMEND SOLDERING PWB LAYOUT
TOLERANCE: 0.05mm

SCALE 8:1
RECOMMEND MATING LAYOUT
TOLERANCE: 0.05mm

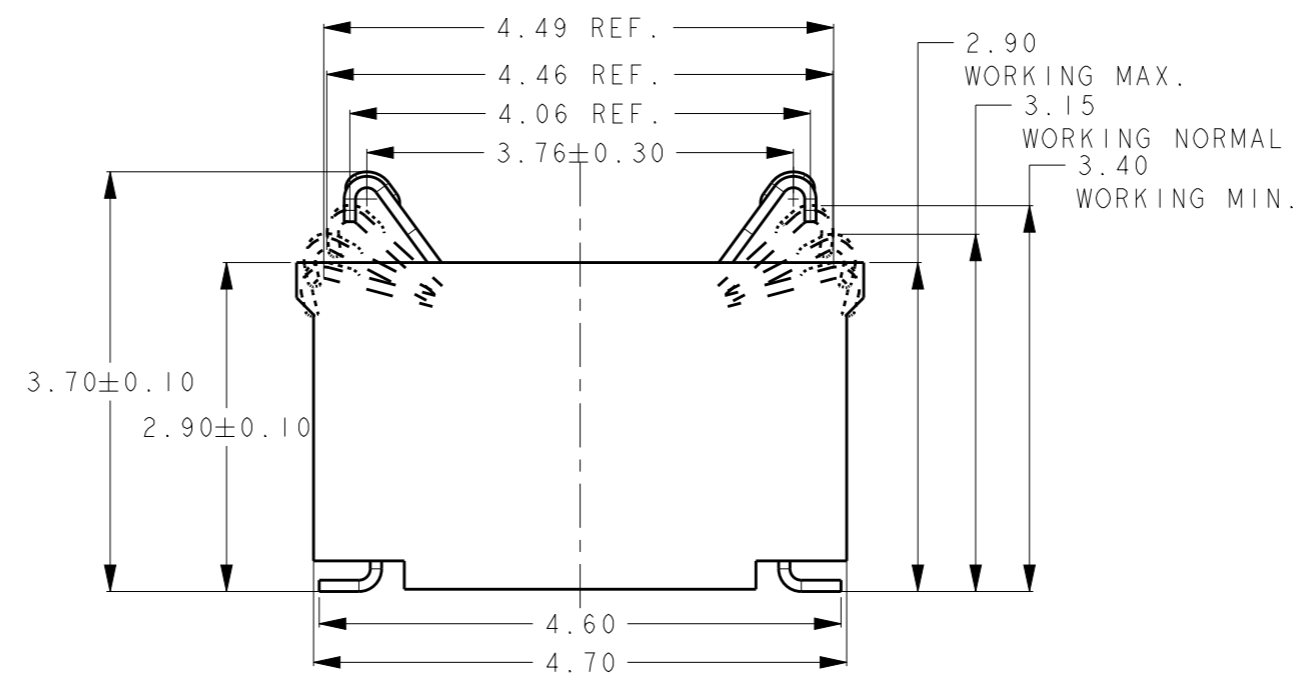
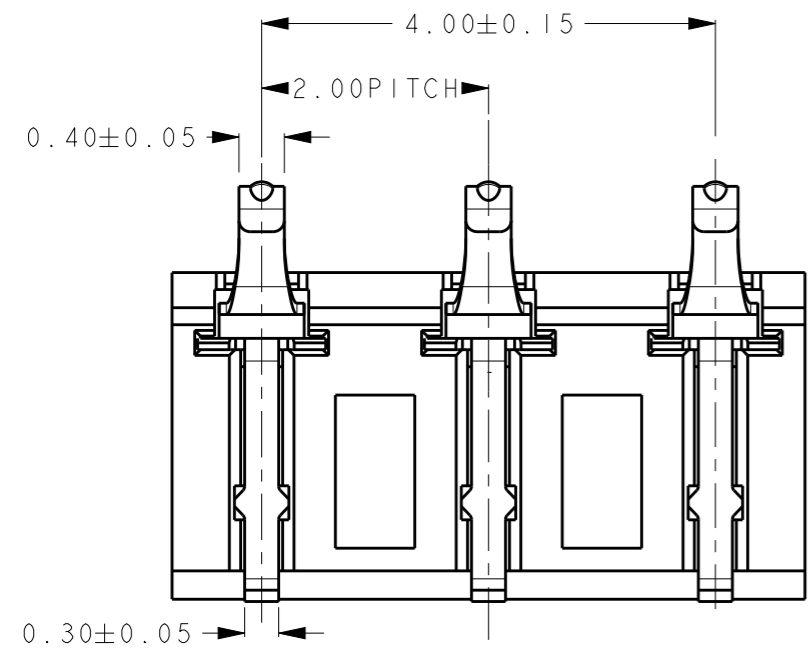

NOTES:
 2 TE PART NUMBER: 2199064-2
 MATERIAL
 TERMINAL: COPPER ALLOY, THICKNESS 0.10mm.
 HOUSING: HIGH TEMPERATURE THERMO PLASTIC
 UL94V-0 BLACK
 3 FINISH
 TERMINAL: 0.10-0.2 um GOLD PLATING ON CONTACT AREA,
 1.25 um MIN. NICKLE UNDER PLATING,
 GOLD FLASH PLATING ON SOLDERING AREA.
 4 COPLANARITY: 0.08 MAX. AMANG ALL SOLDER TAILS.
 5 PACKAGING: TAPE & REEL.
 6 DATE CODE: "XYWWSL"
 VERSION NO. XX = VI
 FOR EXAMPLE: P1, VI, A1.
 P = PROTO TOOL; V = PRODUCTION TOOL; A = MASS APPROVED.
 YYWW = PRODUCTION DATE (YEAR, WEEK, DAY).
 S = SHIFT (D=DYA, N=NIGHT); L = LINE NUMBER.

THIS DRAWING IS A CONTROLLED DOCUMENT.	
DIMENSIONS: mm	TOLERANCES UNLESS OTHERWISE SPECIFIED: ±0.20
	0 PLC ±
	1 PLC ±
	2 PLC ±
	3 PLC ±
	4 PLC ±
	ANGLES ±5°
MATERIAL	FINISH

DWN	26MAR2013
CHK	26MAR2013
APVD	26MAR2013
PRODUCT SPEC	108-115048
APPLICATION SPEC	-
WEIGHT	0.108
CUSTOMER DRAWING	

		TE Connectivity	
		NAME	
ONE PIECE BtoB CONNECTOR		6 PINS, H3.15, TWO ROWS	
SIZE	CAGE CODE	DRAWING NO	RESTRICTED TO
A3	00779	C-2199064	-
SCALE 20:1		SHEET 1	OF 1
		REV	A

SEE SHEET 1

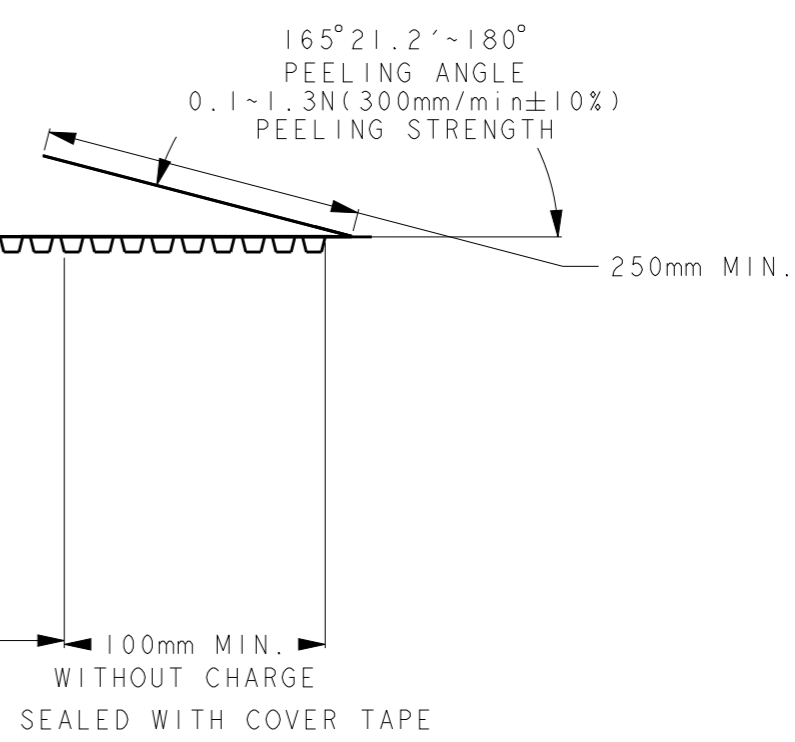
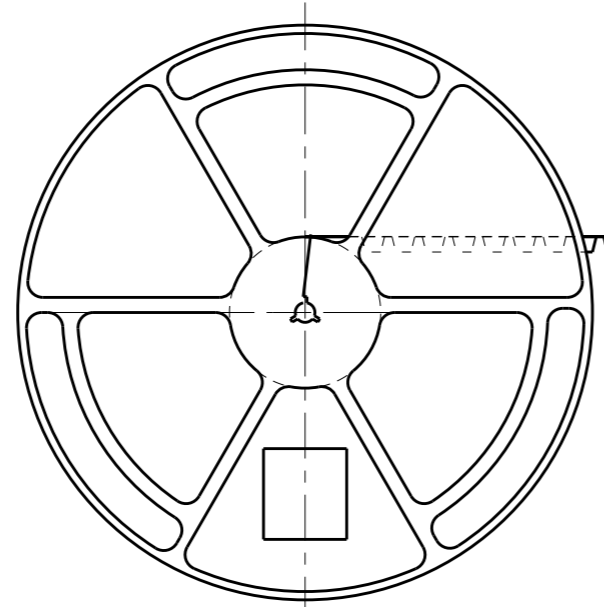
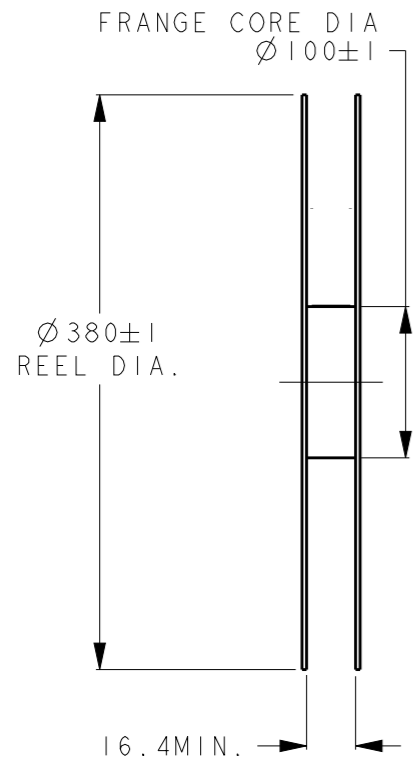
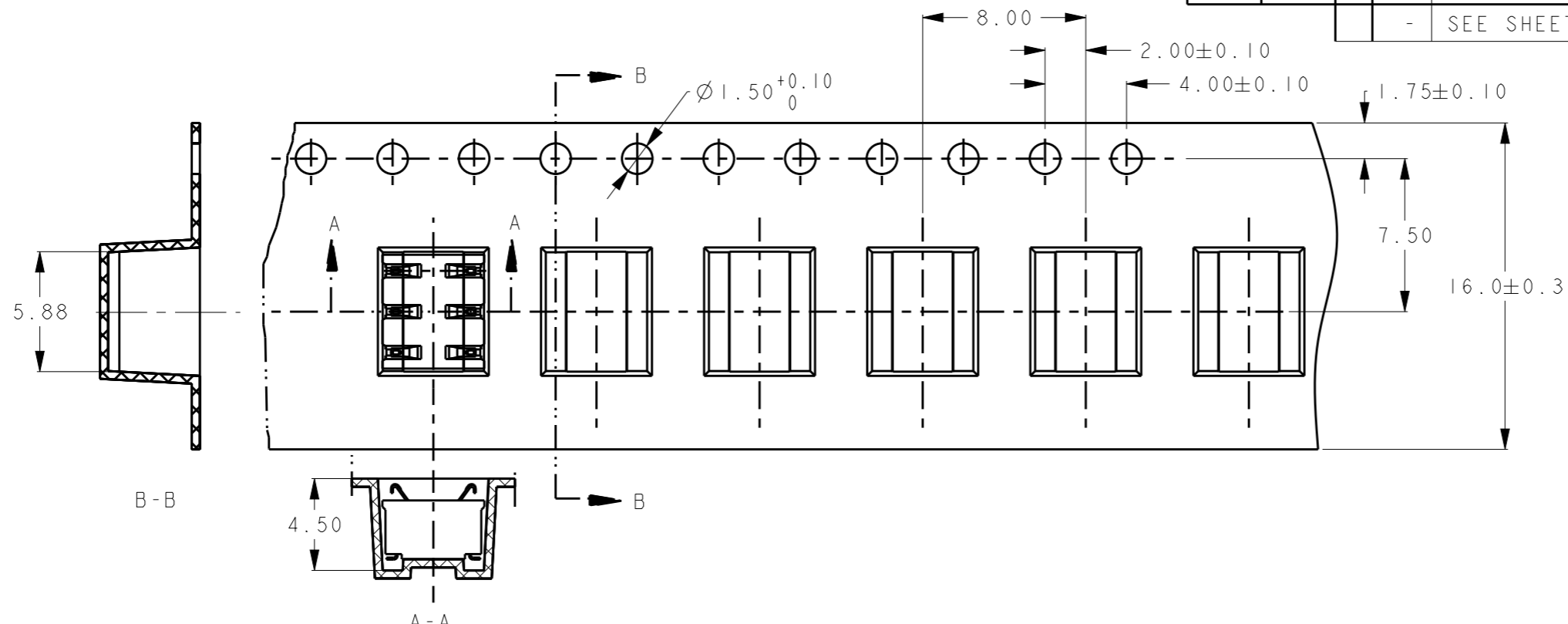



40mm MIN. WITHOUT CHARGE SEaled WITH COVER TAPE

WITH PRODUCT CHARGE 2400PCS

100mm MIN. WITHOUT CHARGE SEaled WITH COVER TAPE

- NOTES:
1. TAPE MATERIAL: P.S; THICKNESS 0.4mm.
 2. QUANTITY PER REEL: 2400PCS.

THIS DRAWING IS A CONTROLLED DOCUMENT.		DWN	26MAR2013	 TE Connectivity	NAME ONE PIECE BtoB CONNECTOR 6 PINS, H3.15, TWO ROWS
DIMENSIONS: mm		CHK	26MAR2013		
		APVD	26MAR2013		
TOLERANCES UNLESS OTHERWISE SPECIFIED: ±0.20		PRODUCT SPEC	-	SIZE	A300779
0-PLC ±		APPLICATION SPEC	-	CAGE CODE	C=2199064
1-PLC ±		WEIGHT	-	DRAWING NO	SCALE 20:1
2-PLC ±		CUSTOMER DRAWING	-	RESTRICTED TO	SHEET 2 OF 1
3-PLC ±				REV	2
4-PLC ±					
ANGLES ±5°					
MATERIAL					
FINISH					

单击下面可查看定价，库存，交付和生命周期等信息

[>>TE Connectivity\(泰科\)](#)