

LOC	DIST	REVISIONS			
P	LTN	DESCRIPTION	DATE	DMN	APVD
A		INITIAL RELEASE	12JUN2012	LW	AC
B		PER ECR-15-015254	04NOV2015	DS	FY

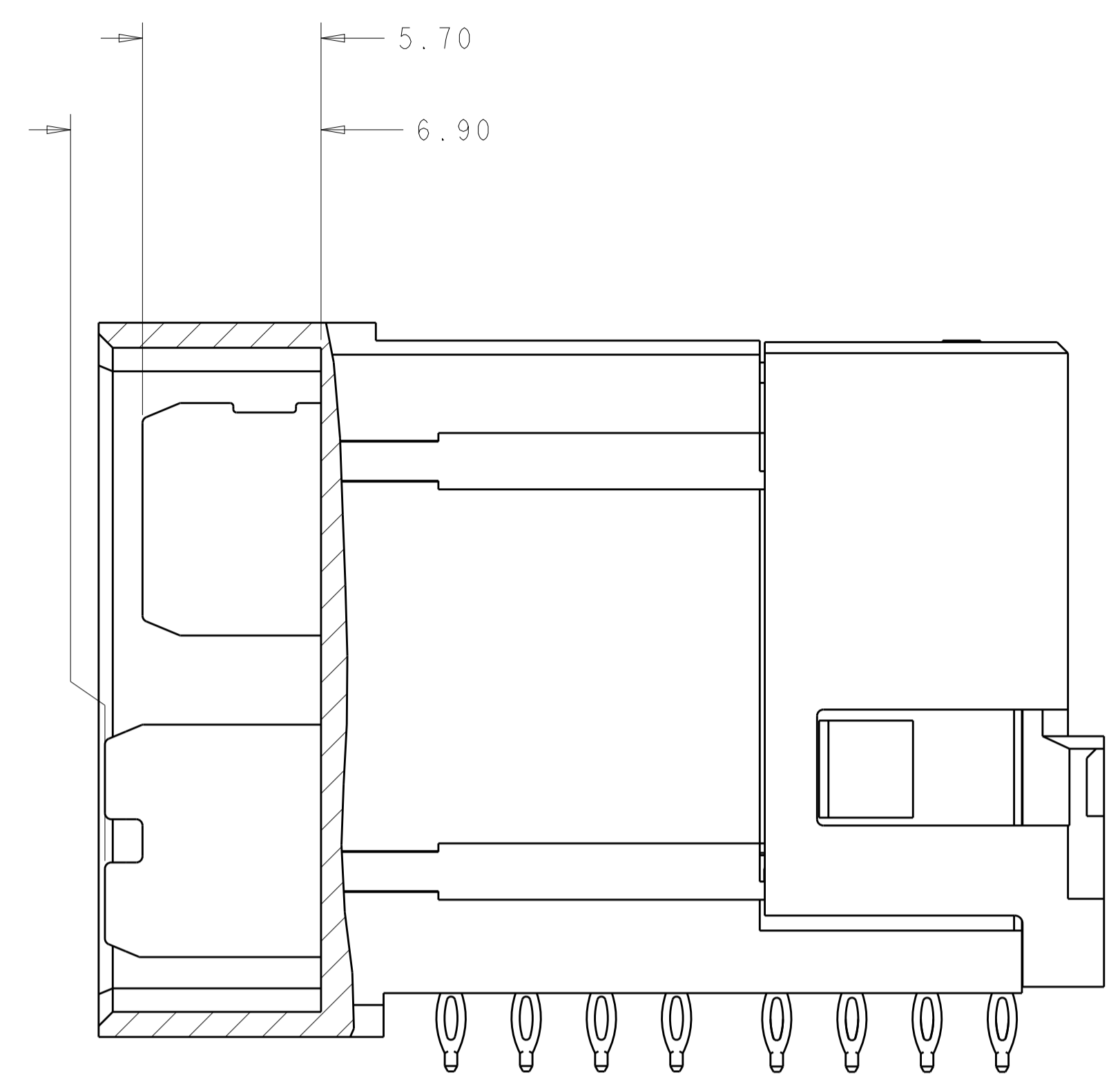

DETAIL FOR CONTACT BLADE

- NOTES:  
 1. MATERIALS:  
 HOUSING: HIGH TEMP. THERMOPLASTIC GLASS/MINERAL FILLED UL94V-0  
 TERMINAL: COPPER ALLOY  
 FINISH:  
 △ TIN OPTION-0.76um MIN GOLD AT CONTACT AREA AND  
 1.27um MIN NICKEL UNDERPLATED OVER ALL  
 2.54um TIN AT SOLDER TAIL AREA  
 TIN-LEAD OPTION-0.76um MIN GOLD AT CONTACT AREA AND  
 1.27um MIN NICKEL UNDERPLATED OVER ALL  
 2.54um TIN-LEAD AT SOLDER TAIL AREA  
 3. PCB NOTE FOR DIAMETER 0.725MM PLATED HOLE.  
 -DRILLED HOLE SIZE IS 0.838MM  
 -PLATED WITH 0.007MM MIN. TIN OVER  
 0.03 TO 0.08MM COPPER UNDERPLATE TO ACHIEVE  
 0.725±0.075MM HOLE.  
 4. CONNECTOR WERE PACKED BY TRAY  
 5. REFER TO TE'S PRODUCT SPECIFICATION: 108-2473  
 FOR TORQUE FORCE AND RETENTION FORCE  
 6. MATED WITH 2169859-\*
- △ PART NUMBER AND DATE CODE AT ASSEMBLY AREA AS APPROXIMATE SHOWN.  
 8. COMPONENT PLACEMENT ZONE

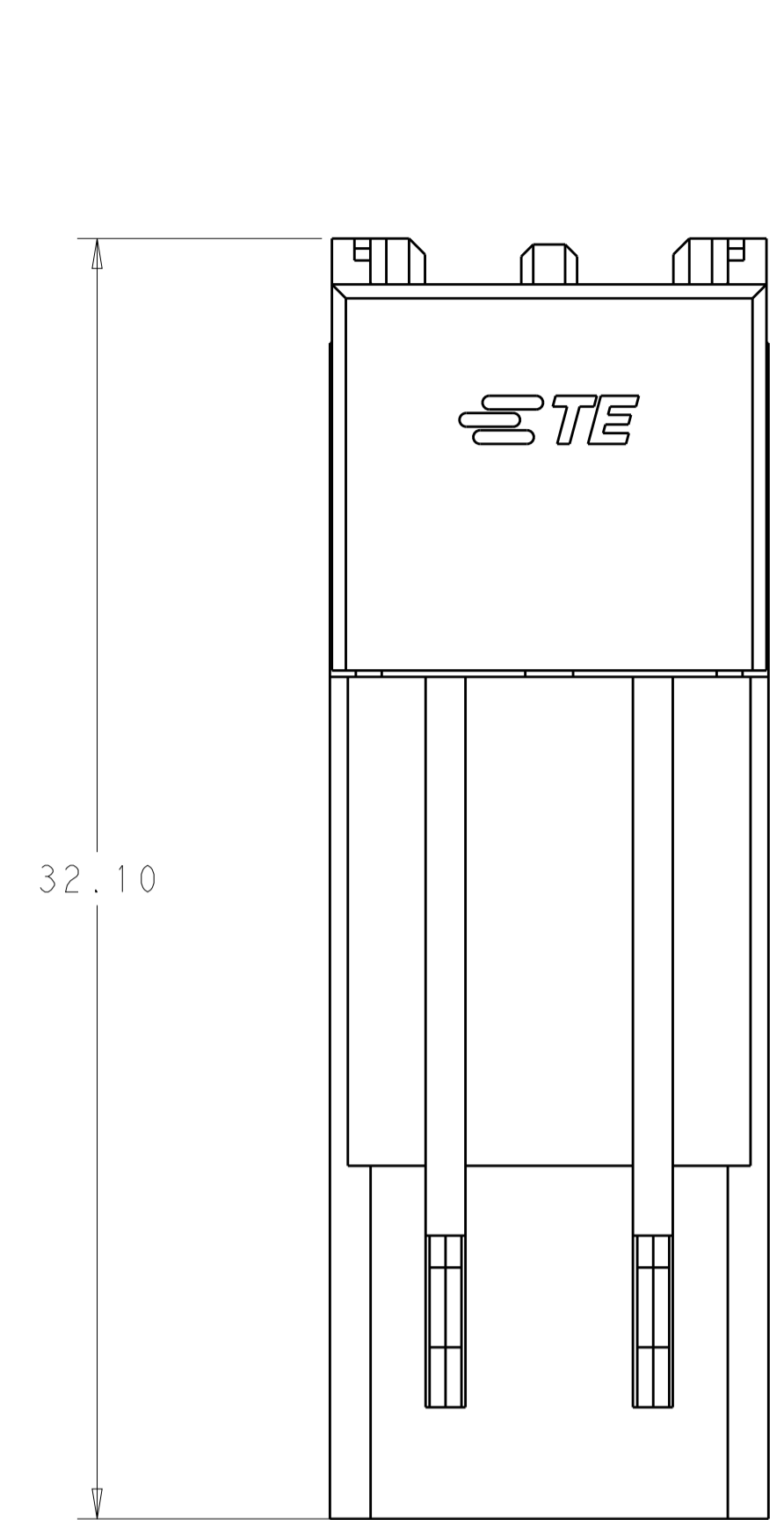
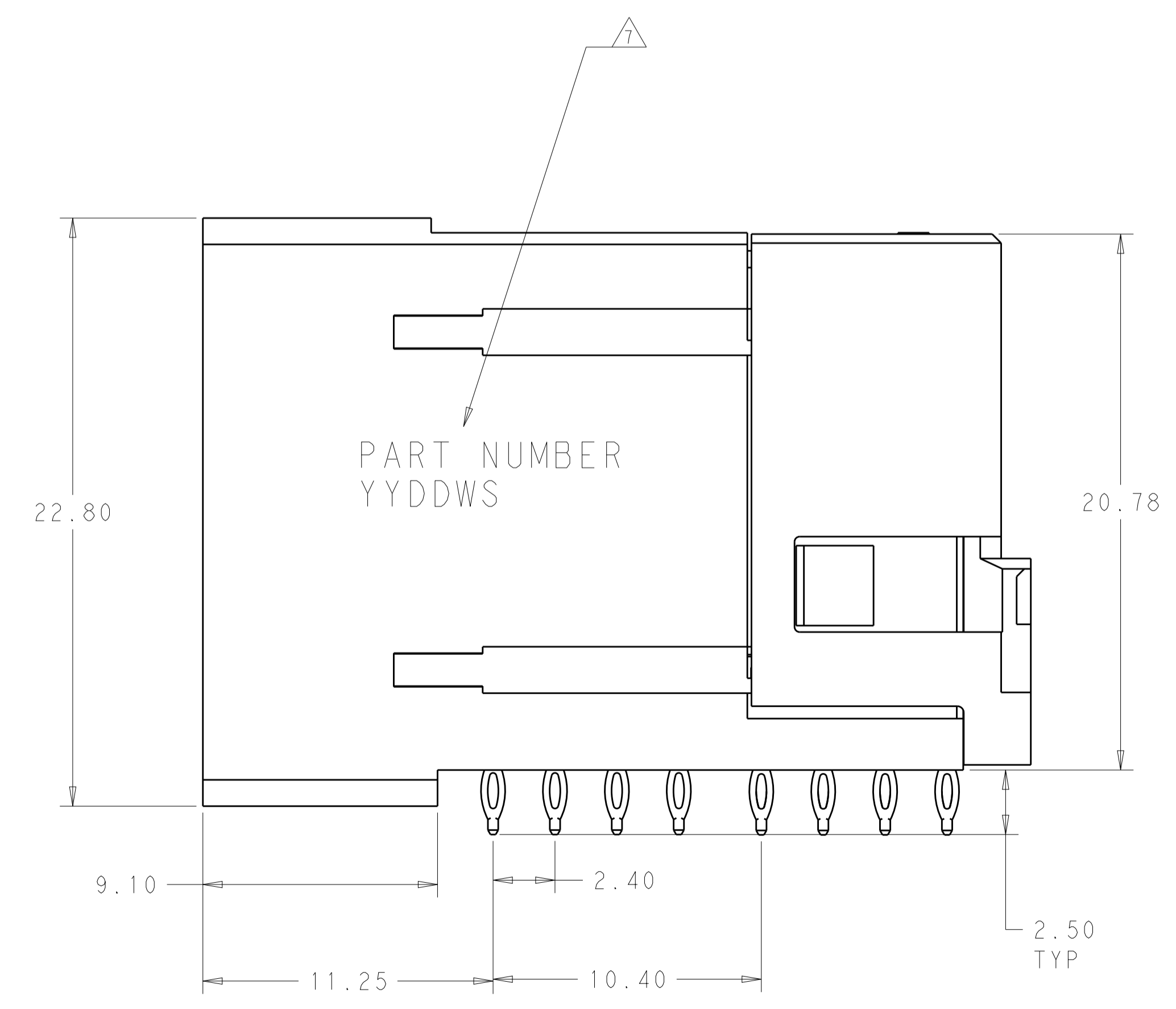
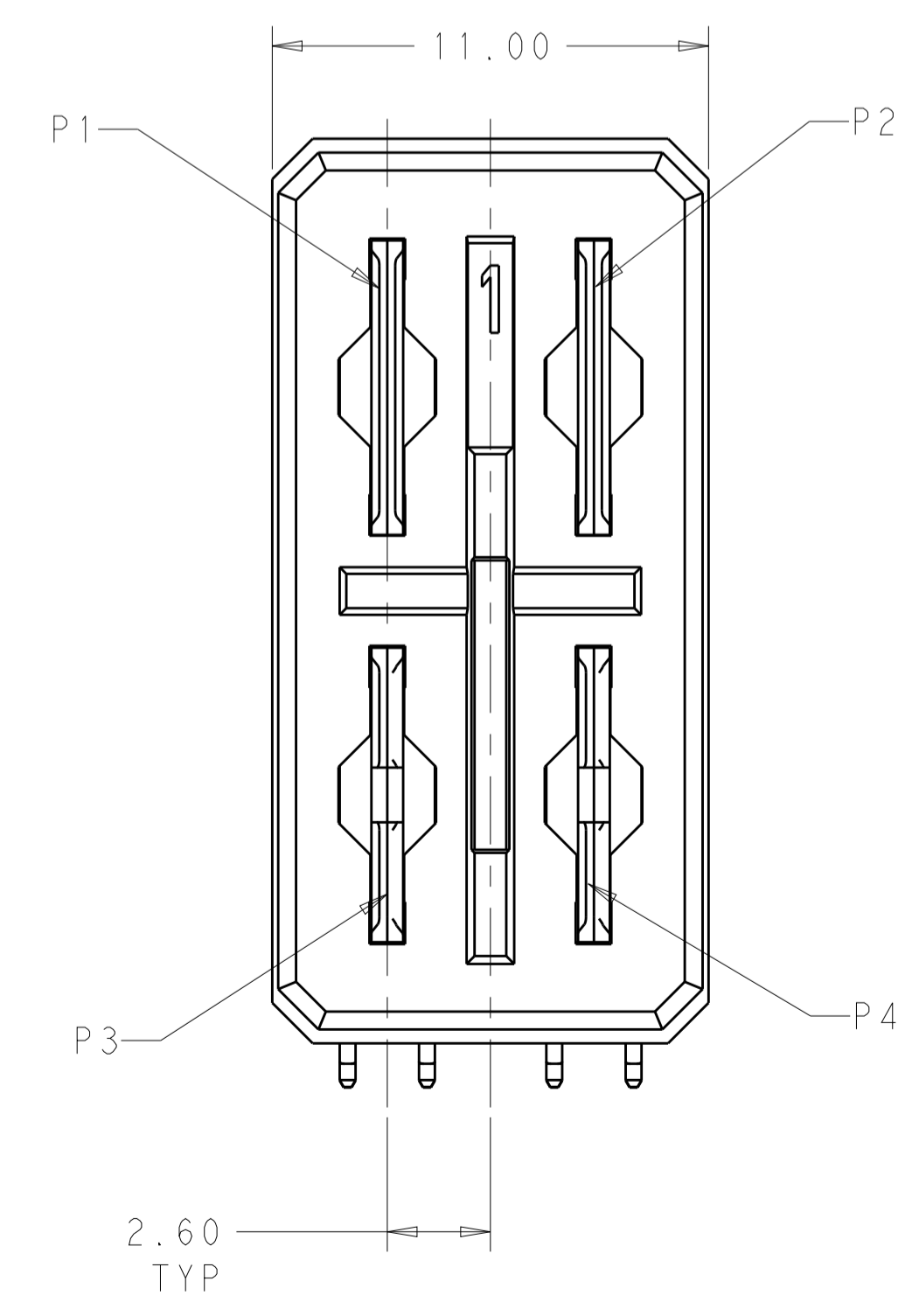

TRAY	TIN PLATING	5.70	5.70	5.70	6.90	2-2169869-2
		6.90	6.90	6.90	6.90	2169869-1
OBSOLETE	TIN-LEAD PLATING	5.70	5.70	5.70	5.70	2169869-2
		6.90	6.90	5.70	5.70	2169869-3
		5.70	5.70	6.90	6.90	2169869-4
		6.90	6.90	6.90	6.90	5-2169869-1
PACKAGING	PLATING OPTION	P1	P2	P3	P4	PART NUMBER
		PIN LENGTH				

LOC	DIST	REVISIONS			
P	LTN	DESCRIPTION	DATE	DMN	APVD
-	-	SEE SHEET 1	-	-	-

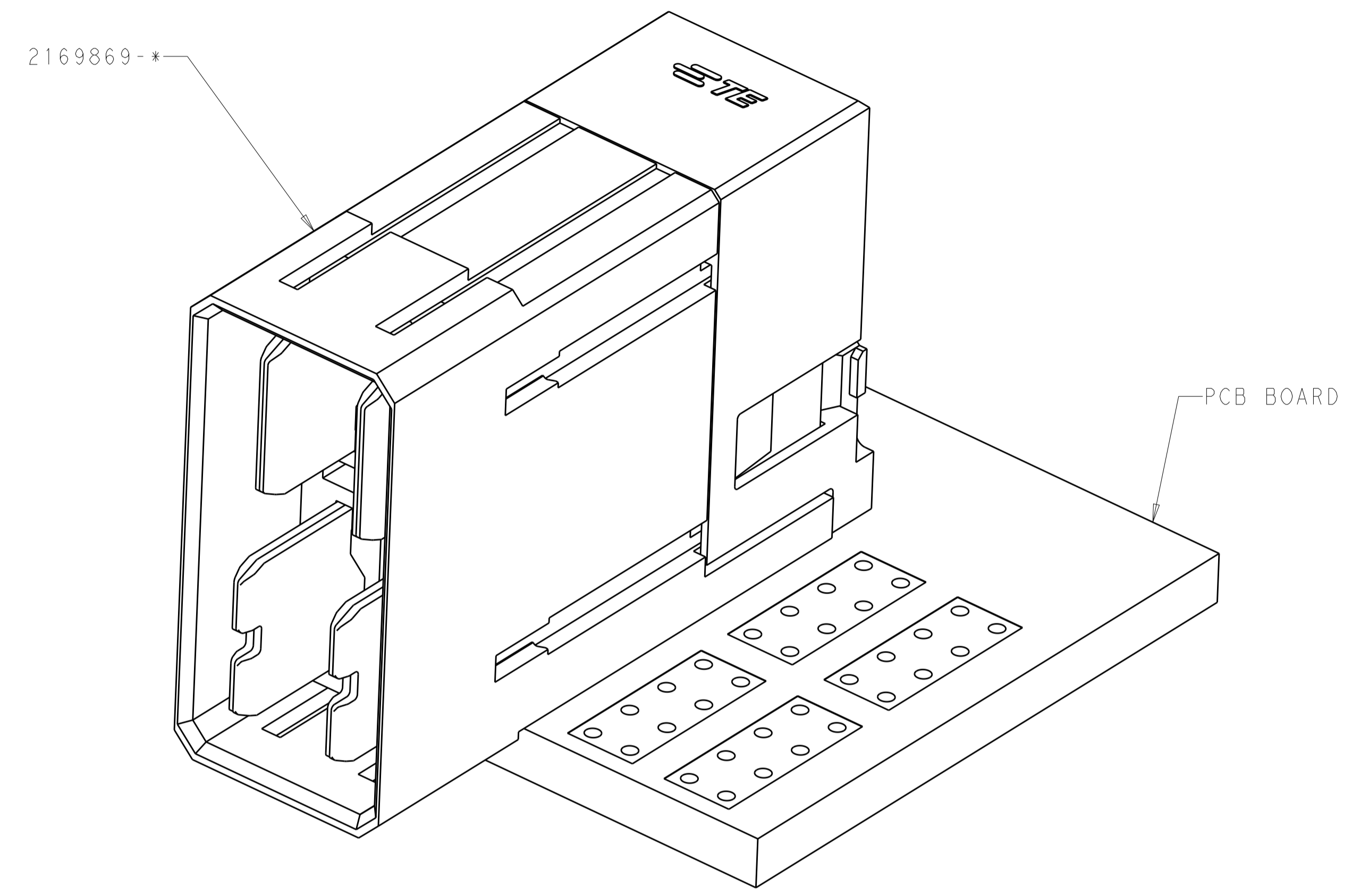

CONNECTOR MATED WITH PCB

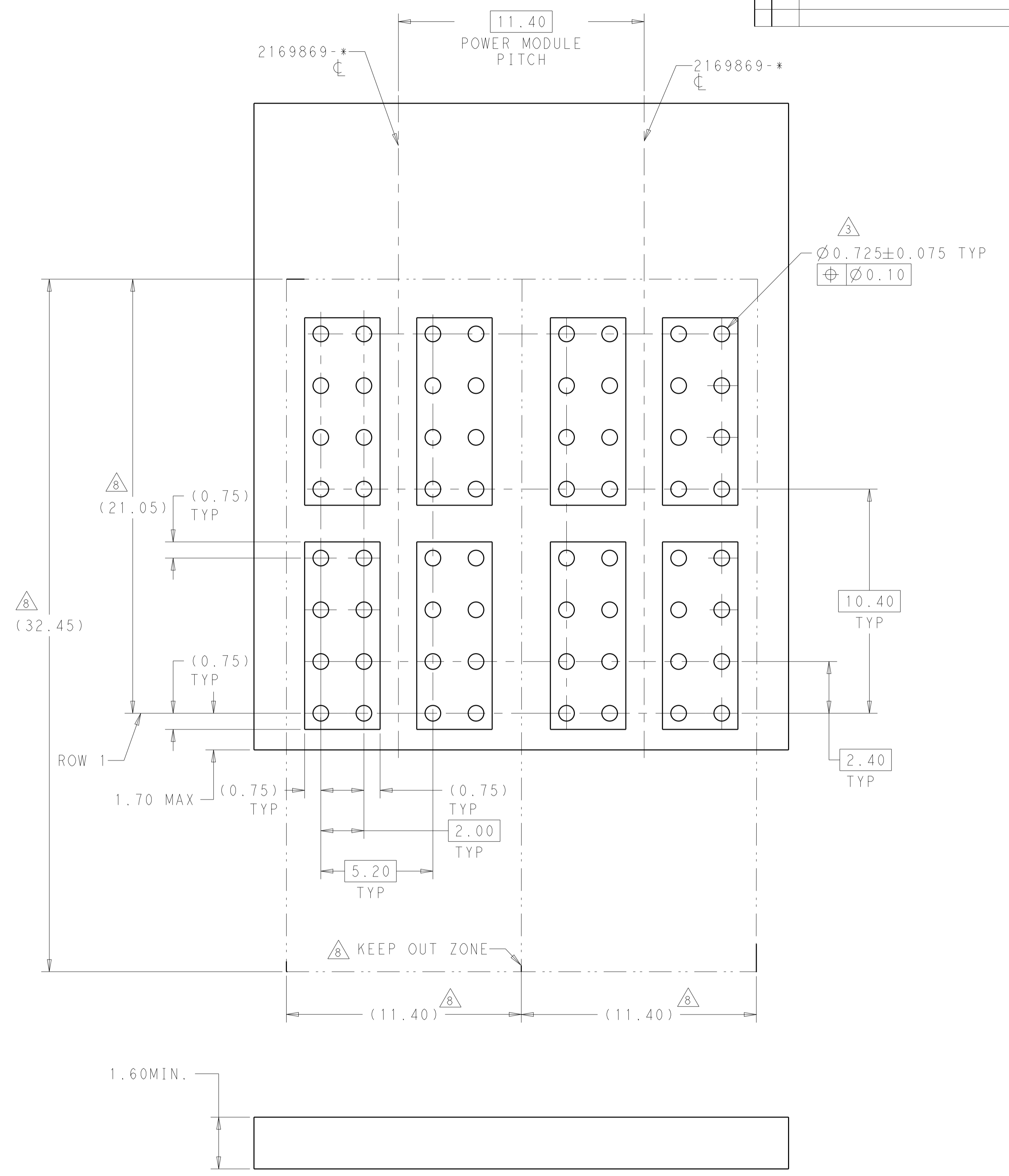

PCB LAYOUT FOR 5PAIR R/A HEADER POWER MODULE  
 (COMPONENT SIDE SHOWN)

<small>THIS DRAWING IS UNPUBLISHED. IT IS THE PROPERTY OF TYCO ELECTRONICS CORPORATION. IT IS TO BE USED ONLY FOR THE PURPOSES SPECIFIED IN THE ORDER. IT IS TO BE RETURNED TO TYCO ELECTRONICS CORPORATION UPON COMPLETION OF THE PROJECT.</small>		DWN: LERRY_WANG 05MAY2011 CHK: SUNY_ZHAO 05MAY2011 APVD: SUNY_ZHAO 05MAY2011	
DIMENSIONS: mm TOLERANCES UNLESS OTHERWISE SPECIFIED: 0 PLC ±.25 1 PLC ±.25 2 PLC ±.25 3 PLC ±.25 4 PLC ±.25 ANGLES ±.1° MATERIAL: - FINISH: -		NAME: ASSEMBLY IMPACT POWER 5PAIR R/A HEADER PRESS-FIT SIZE: A1 CAGE CODE: 00779 DRAWING NO: 2169869	
CUSTOMER DRAWING		WEIGHT: - SCALE: 6:1 SHEET: 2 OF 2 REV: B	

单击下面可查看定价，库存，交付和生命周期等信息

[>>TE Connectivity\(泰科\)](#)