

- ① CONTACT FINISH: .000050 MIN THK. GOLD IN THE CONTACT AREA. GOLD FLASH ON THE REMAINDER, ALL OVER .000050 MIN THK. NICKEL.
- ② POSITION NUMBERS SHOWN FOR REFERENCE PURPOSES ONLY.
- ③ MOUNTING HOLES.
- ④ POST TO BE Sn63 Pb37 SOLDER DIPPED. CONNECTOR MUST MEET APPLICABLE REQUIREMENTS OF MIL-STD-202, METHOD 208.
- ⑤ CONTACT MATL.; GILDING METAL.
- ⑥ TOLERANCE NON CUMULATIVE.
- ⑦ TAB-HOUSING MATL.; FLAME RETARDANT THERMOSET DIALYL PHTHALATE. COLOR; GREEN.
- ⑧ CUT OUT FOR KEYING BOSS, LOCATED WHERE REQD. (OPTIONAL)
- ⑨ AMP, AMP P/N & DATE CODE, MARKED WITH .062±.015 HIGH CHARACTERS, THIS APPROXIMATE AREA.
- ⑩ POST TO BE LEAD FREE SOLDER DIPPED. CONNECTOR MUST MEET APPLICABLE REQUIREMENTS OF MIL-STD-202, METHOD 208, EXCEPT 4 HOURS ±15 MINUTE STEAM AGE AND TEST IN 270° C SOLDER POT

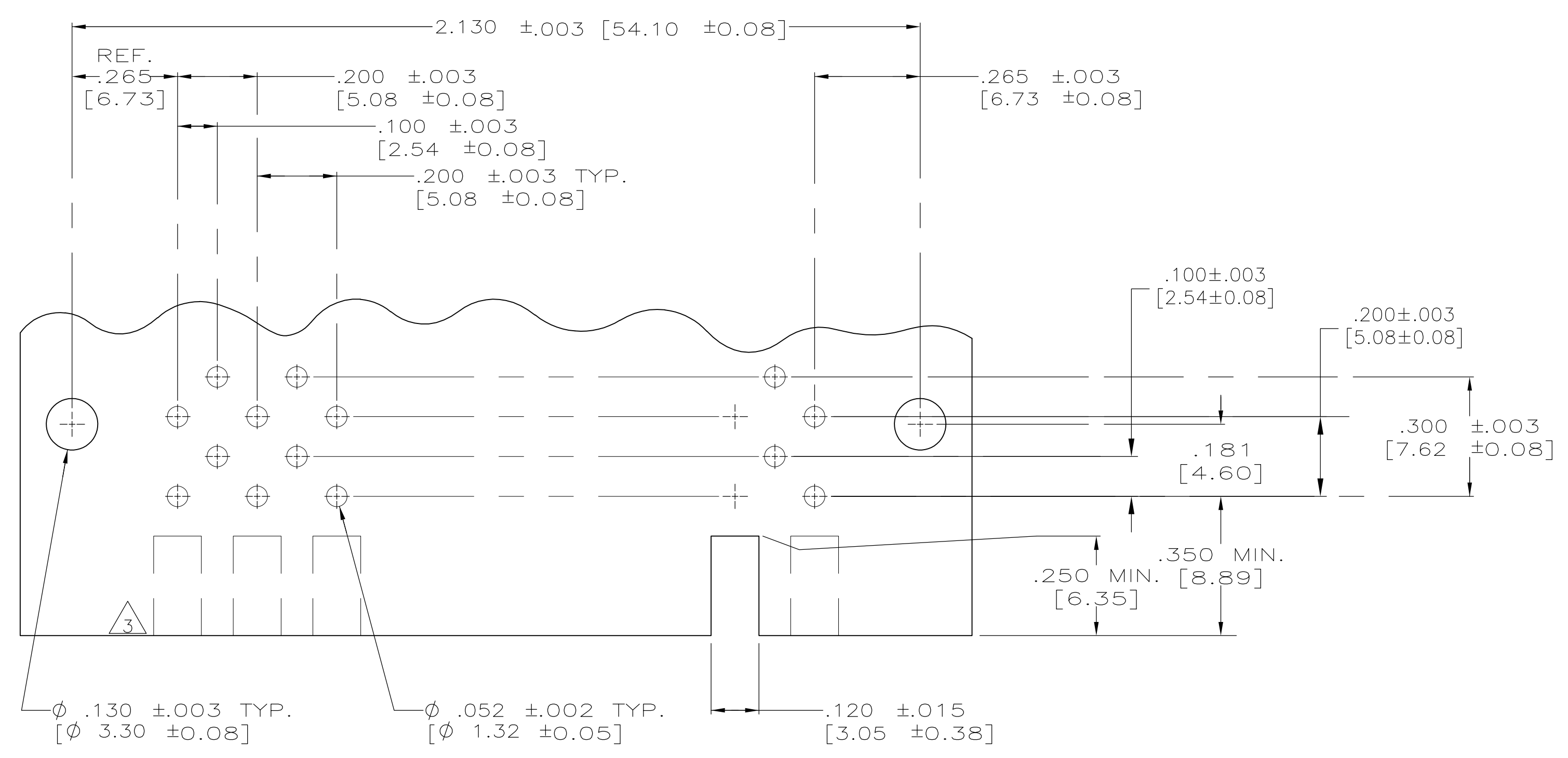

LEAD FREE	⑩	①	5-445222-1
	④	①	445222-1
REMARKS	FINISH	PART NO.	

THIS DRAWING IS A CONTROLLED DOCUMENT.		DWN W. LEUFERT	2-2-90	Tyco Electronics Corporation Harrisburg, Pa 17105-3608	
DIMENSIONS: INCHES		CHK J.E. WARNER	3-14-91	NAME J.E. WARNER	
TOLERANCES UNLESS OTHERWISE SPECIFIED:		PRODUCT SPEC		ASSEMBLY, AMP BLADE, TAB HOUSING .100 x .125	
0 PLC ± -		APPLICATION SPEC		SIZE A1	
1 PLC ± -		WEIGHT		CAGE CODE 00779	
2 PLC ± -		CUSTOMER DRAWING		DRAWING NO 445222	
3 PLC ± .005 [013]		SCALE	4:1	SHEET 1 OF 1	
4 PLC ± -		REV		REV J	
ANGLES ± -					
FINISH SEE TABLE					

单击下面可查看定价，库存，交付和生命周期等信息

[>>TE Connectivity\(泰科\)](#)