

THIS DRAWING IS UNPUBLISHED. RELEASED FOR PUBLICATION
 © COPYRIGHT 2005 By - ALL RIGHTS RESERVED.

LOC	DIST	REVISIONS			
P	LTR	DESCRIPTION	DATE	DWN	APVD
GP	00	D	REVISED PER ECO-14-011808	11AUG2014	AP SB

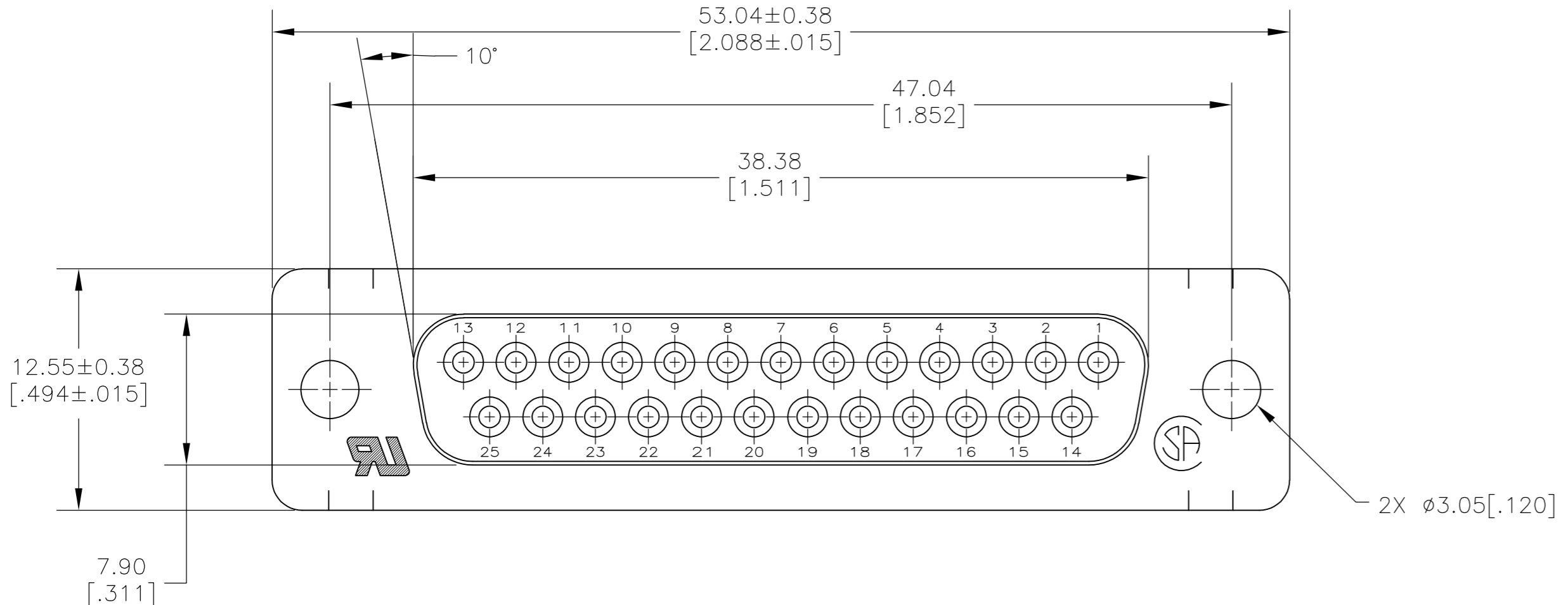

- 1 MOLDED PARTS: GLASS-FILLED PBT OR GLASS-FILLED NYLON, UL94V-0 RATED. COLOR: BLACK.
SHELLS: CARBON STEEL.
CONTACTS: PHOS BRONZE.
- 2 SHELLS: 5.08µm [.000200] MIN TIN OVER 2.54µm [.000100] MIN COPPER.
CONTACTS: SEE TABLE
- 3 GOLD FLASH ON MATING END, 2.54µm [.000100] MIN TIN ON SOLDER END, BOTH OVER 1.27µm [.000050] MIN NICKEL.
- 4 0.76µm [.000030] MIN GOLD ON MATING END, 2.54µm [.000100] MIN TIN ON SOLDER END, BOTH OVER 1.27µm [.000050] MIN NICKEL.
-OR-
GOLD FLASH OVER PALLADIUM-NICKEL 0.76µm [.000030] MIN TOTAL ON MATING END, 2.54µm [.000100] MIN TIN ON SOLDER END, BOTH OVER 1.27µm [.000050] MIN NICKEL.

TYCO, PART NO & DATE CODE, MARKED IN AREA INDICATED, ON FAR SIDE

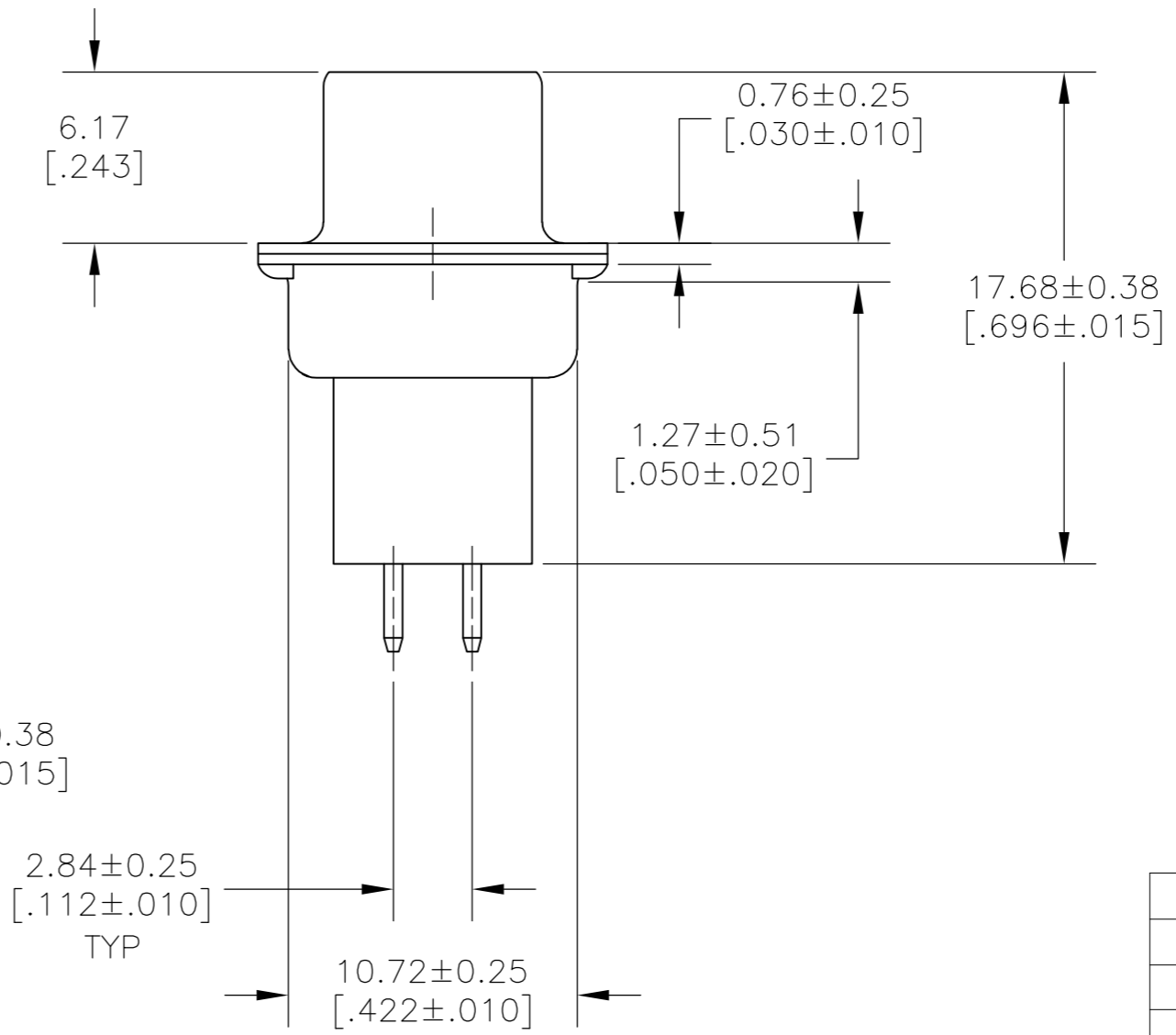
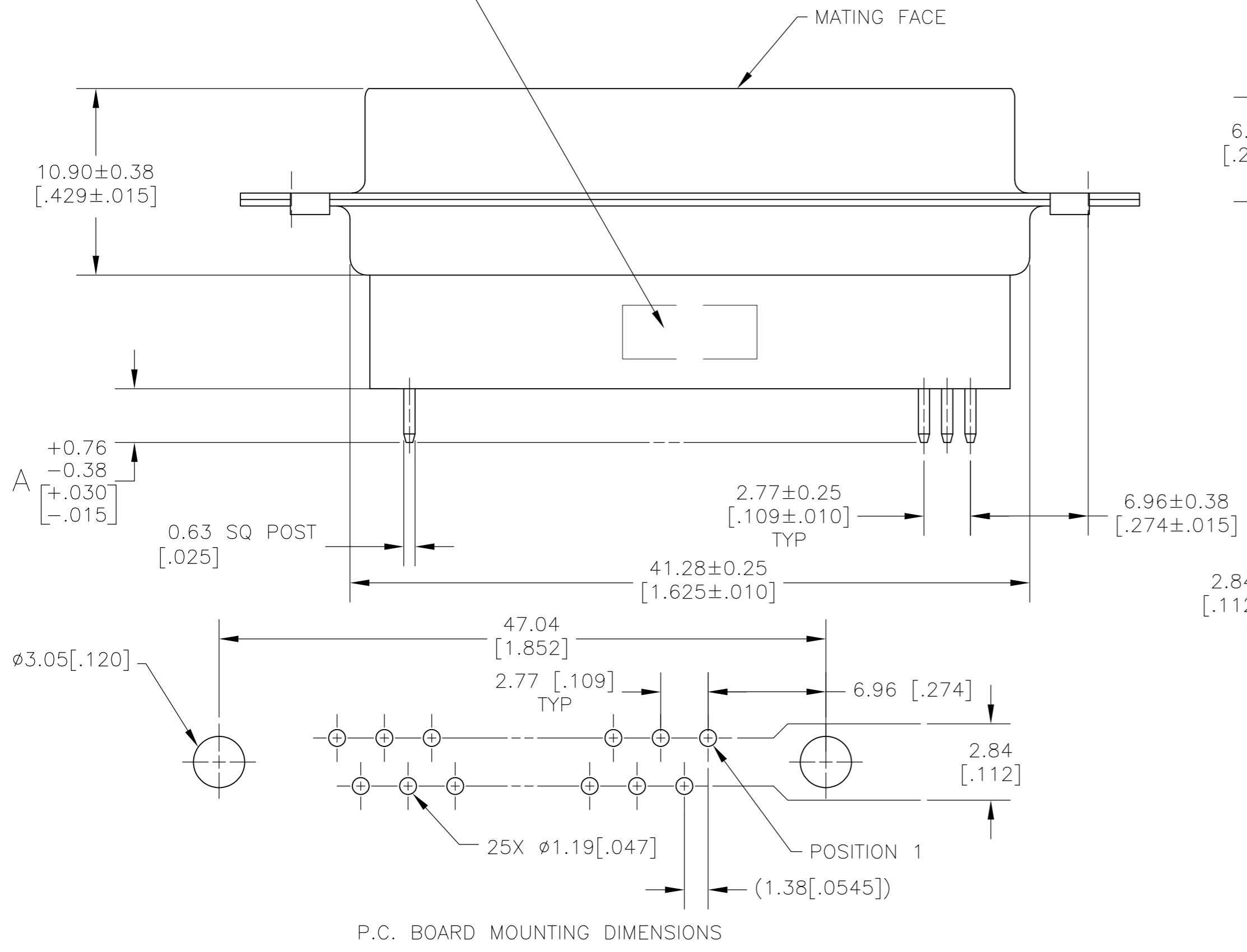

CONTACT FINISH	DIMENSION A	PART NO
3	4.77 [.188]	5745187-8
4	4.77 [.188]	5745187-7
4	10.84 [.427]	5745187-3
4	3.17 [.125]	5745187-1

THIS DRAWING IS A CONTROLLED DOCUMENT.

DIMENSIONS: mm[INCHES]	TOLERANCES UNLESS OTHERWISE SPECIFIED:	DWN B. LATTUCA 14SEPT05	TE Connectivity
	0 PLC ± -	CHK S. BOLASH 14SEPT05	RECEPTACLE ASSEMBLY, SIZE 3, 25 POSITION, VERTICAL, AMPLIMITE HDP
	1 PLC ± -	APVD M. WALMSLEY 14SEPT05	SIZE A2 CAGE CODE 00779 DRAWING NO C=5745187
	2 PLC ± -	PRODUCT SPEC 108-40025	RESTRICTED TO -
	3 PLC ± 0.13 [.005]	APPLICATION SPEC 114-40013	SCALE NTS SHEET 1 of 1 REV D
	4 PLC ± -	WEIGHT -	
	ANGLES ± 2°	CUSTOMER DRAWING	
MATERIAL 1	FINISH 2		

单击下面可查看定价，库存，交付和生命周期等信息

[>>TE Connectivity\(泰科\)](#)

[>>点击查看相关商品](#)