

REVISIONS					
P	LTR	DESCRIPTION	DATE	DWN	APVD
	E3	REVISED PER ECO-12-002692	13FEB12	KH	DR
	E4	REVISED PER ECO-17-007400	18DEC2017	RS	DR

AMP WIRE RANGE	 FILE E66717
22-16 AWG SOLID OR STRANDED	22-16 AWG SOLID OR STRANDED

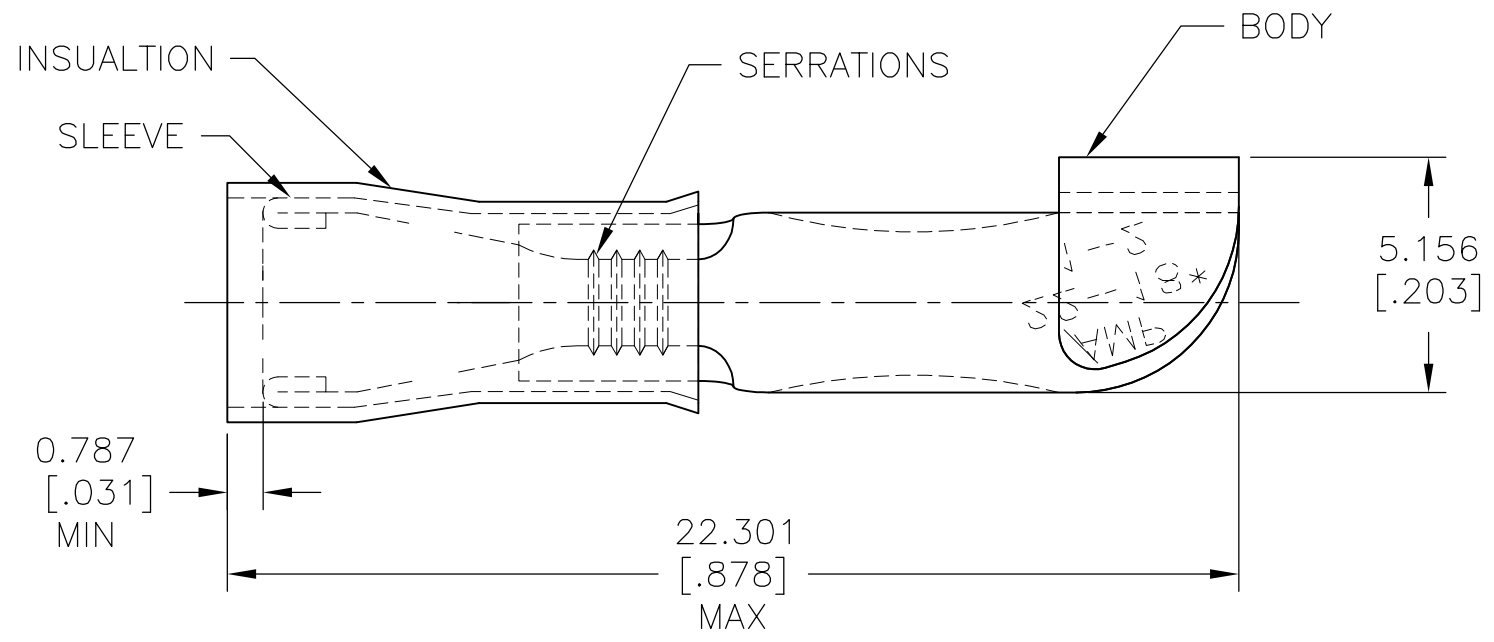

- 1 STAMP AMP 22-18* APPROX AS SHOWN
22-16 TERMINALS ARE STAMPED 22-18 IN
ACCORDANCE WITH MILITARY SPEC SAE AS7928
COMMERCIAL WIRE RANGE IS 22-16
- 2 WIRE INSUL : $\phi 2.032-3.175[\phi .080-.125]$
- 3 MATERIAL: BODY - CU PER ASTM B152
SLEEVE - CU PER ASTM B152
INSULATION - NYLON
- 4 FINISH: BODY & SLEEVE: TIN PER ASTM B-545
INSULATION - COLOR: RED
- 5 NOTE DELETED.

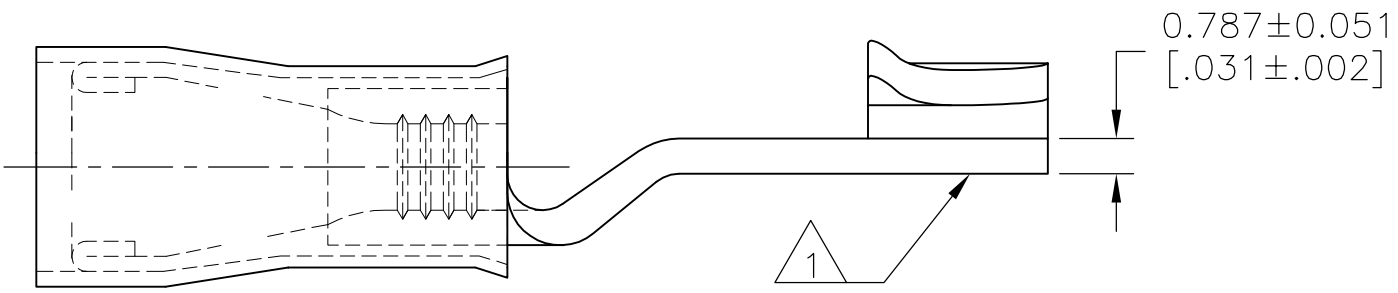

500	LOOSE PIECE	320555
QTY	PACKAGE TYPE	PART NO

AMP INCORPORATED CUSTOMER SERVICE SYSTEMS	
FOR ADDITIONAL PRODUCT INFORMATION OR COPIES OF DRAWINGS AND TECHNICAL DOCUMENTS	PRODUCT INFORMATION CENTER 1-800-522-6752
FOR APPLICATION TOOLING INFORMATION	TOOLING ASSISTANCE CENTER 1-800-722-1111
FOR ORDER ENTRY	1-800-526-5142

MAX RECOMMENDED OPERATING TEMPERATURE: 105°C [221°F]
VOLTAGE RATING: 300 V MAX
CIRCULAR MIL AREA: 0.26-1.65mm ² [509-3260] SOLID OR STRANDED

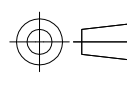
THIS DRAWING IS A CONTROLLED DOCUMENT.	
DIMENSIONS: mm [INCHES]	TOLERANCES UNLESS OTHERWISE SPECIFIED:
	0 PLC ± - 1 PLC ± - 2 PLC ± - 3 PLC ± 0.127[.005] 4 PLC ± - ANGLES ± 5°
MATERIAL	FINISH
3	4

DWN jr_ruth	12JUN09
CHK TOM MICHIELUTTI	12JUN09
APVD TOM MICHIELUTTI	12JUN09
PRODUCT SPEC	UL 486A
APPLICATION SPEC	114-2157
WEIGHT	-
CUSTOMER DRAWING	

 TE Connectivity			
NAME TERMINAL, P.I.D.G., KNIFE DISCONNECT, WIRE SIZE: 22-16			
SIZE	CAGE CODE	DRAWING NO	RESTRICTED TO
A3	00779	C-320555	-
SCALE 6:1		SHEET 1 OF 1	REV E4

单击下面可查看定价，库存，交付和生命周期等信息

[>>TE Connectivity\(泰科\)](#)