

THIS DRAWING IS UNPUBLISHED. RELEASED FOR PUBLICATION 20
 © COPYRIGHT 20 BY - ALL RIGHTS RESERVED.

REVISIONS

P	LTR	DESCRIPTION	DATE	DWN	APVD
	E	PACKAGING CHANGED FROM BLACK POLYURETHANE SPONGE TO TRAY	29MAR2018	RK	PS

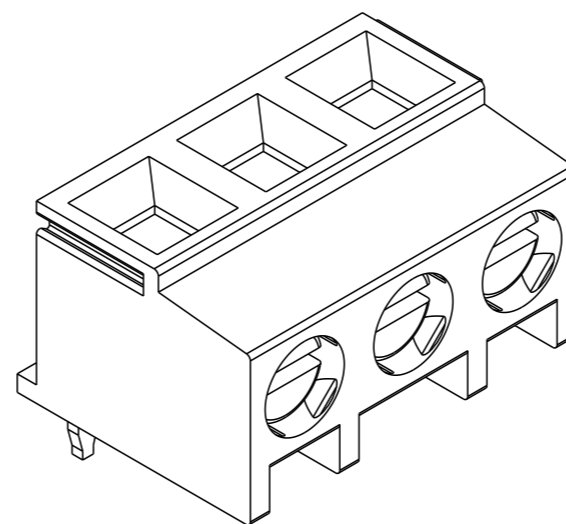
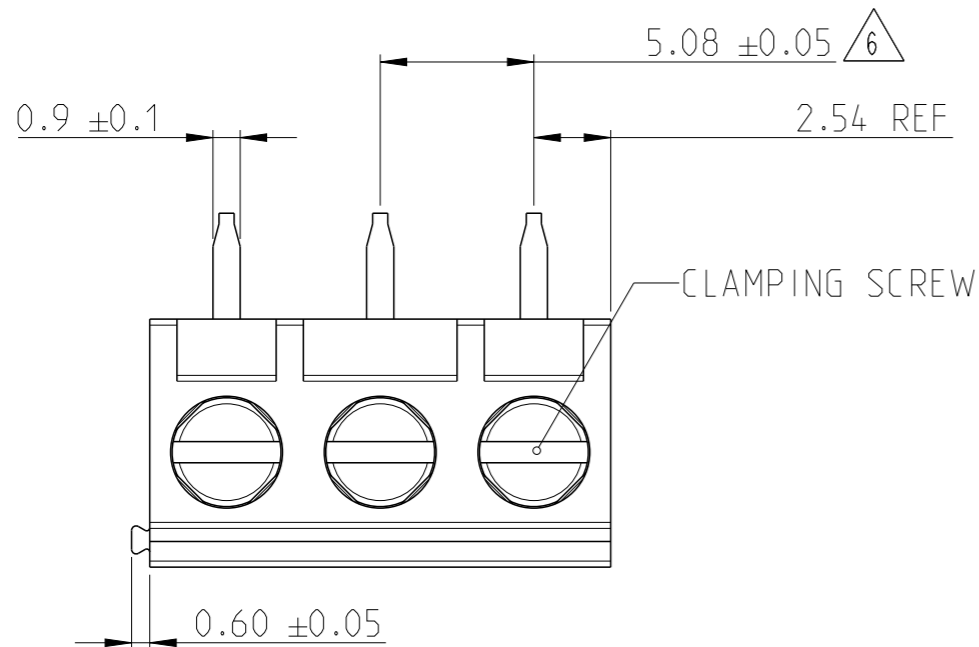

284094-3 AS SHOWN

DIM. A	NO OF POS.	PART NUMBER
127.00	25	2-284094-5
121.92	24	2-284094-4
116.76	23	2-284094-3
111.76	22	2-284094-2
106.68	21	2-284094-1
101.68	20	2-284094-0
96.52	19	1-284094-9
91.44	18	1-284094-8
86.36	17	1-284094-7
81.28	16	1-284094-6
76.20	15	1-284094-5
71.12	14	1-284094-4
66.04	13	1-284094-3
60.96	12	1-284094-2
55.88	11	1-284094-1
50.80	10	1-284094-0
45.72	9	284094-9
40.64	8	284094-8
35.56	7	284094-7
30.48	6	284094-6
25.40	5	284094-5
20.32	4	284094-4
15.24	3	284094-3
10.16	2	284094-2

OBSOLETE

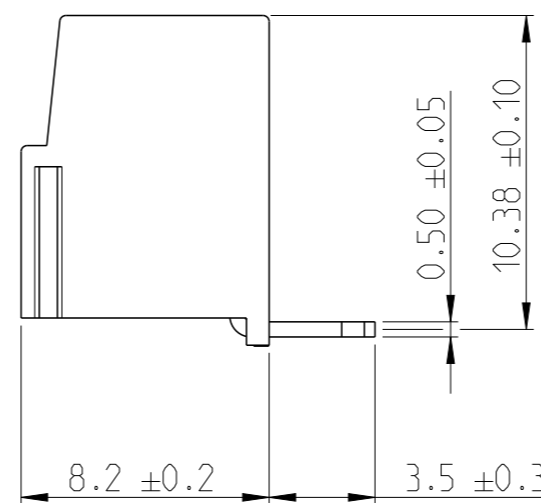
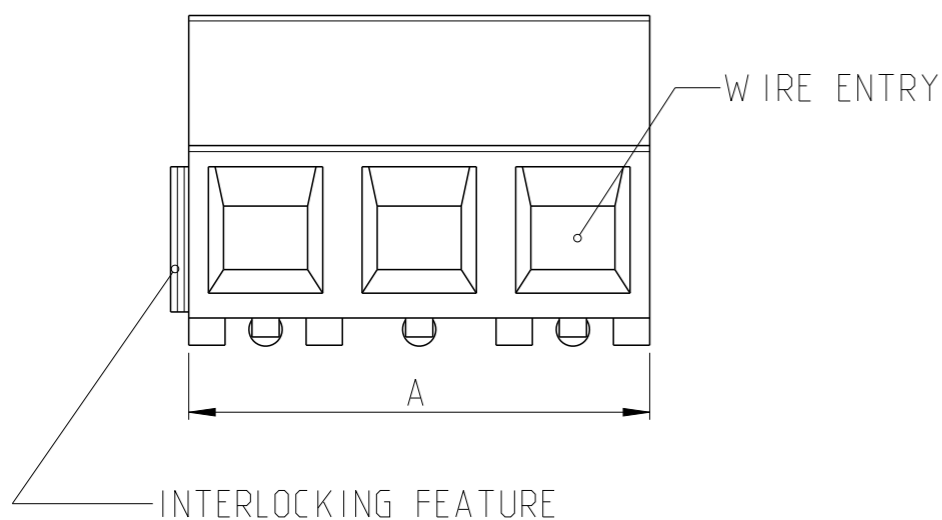

RECOMMENDED PCB BOARD LAYOUT (DIMA DI FORATURA CONSIGLIATA)

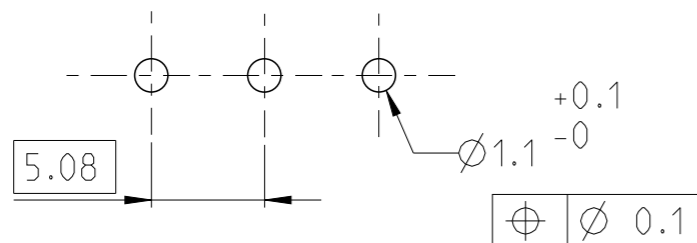

THIS DRAWING IS A CONTROLLED DOCUMENT.		DWN E. ZANOLINI 26APR2001	TE Connectivity	
DIMENSIONS: mm		CHK D. BIEVENOUR 26APR2001		
TOLERANCES UNLESS OTHERWISE SPECIFIED:		APVD D. BIEVENOUR 26APR2001	NAME TERMINAL BLOCK, PCB MOUNT TOP ENTRY WIRE, STACKING W/INTERLOCK, 5.08mm PITCH	
0 PLC ±		PRODUCT SPEC 108-20166	SIZE A3	CAGE CODE 00779
1 PLC ±0.3		APPLICATION SPEC 114-20079	DRAWING NO C=284094	RESTRICTED TO
2 PLC ±0.25		WEIGHT -		
3 PLC ±		CUSTOMER DRAWING	SCALE 4:1	SHEET 1 OF 2
4 PLC ±				REV E
ANGLES ±°				
FINISH SEE NOTES				

THIS DRAWING IS UNPUBLISHED.

RELEASED FOR PUBLICATION

20

© COPYRIGHT 20

BY -

ALL RIGHTS RESERVED.

REVISIONS

P	LTR	DESCRIPTION	DATE	DWN	APVD
-		SEE SHEET 1	-	-	-

NOTES:

- MATERIALS AND FINISH
HOUSING: PA 6-6, UL 94-V0, COLOR GREEN.
CLAMP: BRASS, NICKEL PLATED.
TERMINAL: BRASS, TIN PLATED.
CLAMPING SCREW: M3, BRASS, NICKEL PLATED.
 - MECHANICAL
WIRE STRIPPING LENGTH : 5.0-6.0 mm
MIN. PC BOARD HOLES DIAMETER : 1.1 mm
MAX. PC BOARD THICKNESS : 2.4 mm
RECOMMENDED TIGHTENING TORQUE FOR SCREW : 0.5 Nm.
 - ELECTRICAL
WIRE RANGE : 16-30 AWG
MAX. VOLTAGE : 300 V
MAX CURRENT : 13.5 A
CONTACT RESISTANCE : <15 m Ohm
INSULATION RESISTANCE : >1000 M Ohm (500V DC)
 - RECOGNIZED UNDER THE COMPONENT PROGRAM OF UNDERWRITERS LABORATORIES INC., FILE NO E60677.
 - OPERATING TEMPERATURE RANGE: -40°C TO +110°C
-  NOT CUMULATIVE TOLERANCE.
- PACKED IN TRAY.

THIS DRAWING IS A CONTROLLED DOCUMENT.		DWN E. ZANOLINI 26APR2001	 TE Connectivity	
DIMENSIONS: mm		CHK D. BIEVENOUR 26APR2001		
TOLERANCES UNLESS OTHERWISE SPECIFIED:		APVD D. BIEVENOUR 26APR2001	NAME TERMINAL BLOCK, PCB MOUNT TOP ENTRY WIRE, STACKING W/INTERLOCK, 5.08mm PITCH	
0 PLC ±-		PRODUCT SPEC 108-20166	RESTRICTED TO	
1 PLC ±0.2		APPLICATION SPEC 114-20079	SIZE A3	CAGE CODE 00779
2 PLC ±0.25		WEIGHT -	DRAWING NO C=284094	SCALE 1:1
3 PLC ±-		SHEET 2 OF 2		
4 PLC ±-		REV E		
ANGLES ±2°		CUSTOMER DRAWING		
MATERIAL SEE NOTES	FINISH SEE NOTES			

单击下面可查看定价，库存，交付和生命周期等信息

[>>TE Connectivity\(泰科\)](#)