

THIS DRAWING IS UNPUBLISHED. RELEASED FOR PUBLICATION
 © COPYRIGHT - By - ALL RIGHTS RESERVED.

LOC	DIST	REVISIONS					
GP	00	P	LTR	DESCRIPTION	DATE	DWN	APVD
		AG2		REVISED PER ECO-11-004835	11MAR11	RK	HMR

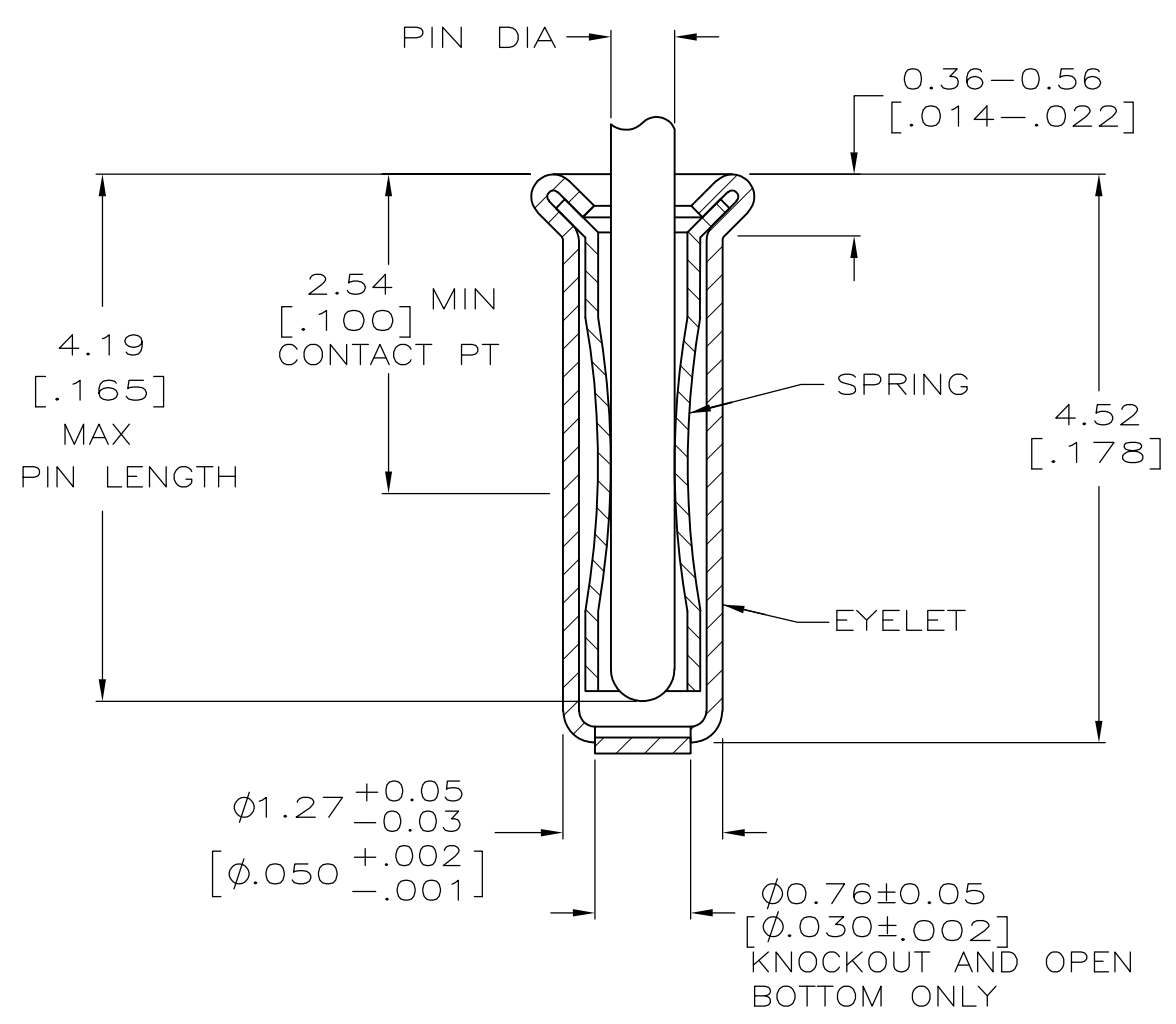
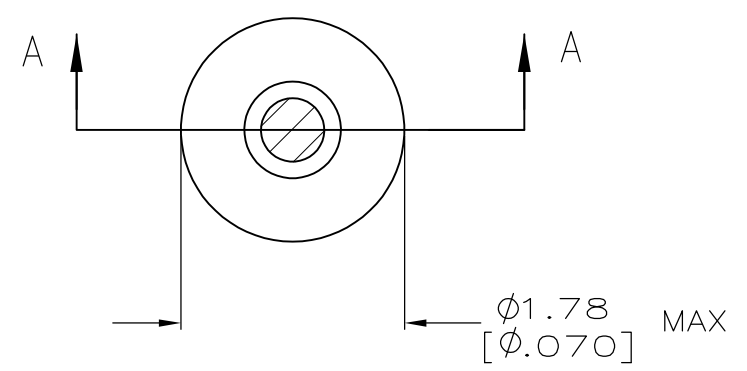

SECTION A-A

- 1. TIN PER MIL-T-10727 OR TIN LEAD .000254 [.000100] MIN THK.
- 2. GOLD PER MIL-G-45204, TYPE II, 0.00076 [.000030] MIN THK OVER NICKEL PER QQ-N-290 0.00028 [.000011] MIN THK ON CONTACT AREA.
- 3. GOLD FLASH PER MIL-G-45204, TYPE II, 0.13µm [.000005] MIN THK. OVER NICKEL PLATE PER QQ-N-290 0.51µm-1.52µm [.000020-.000060] EXT THK.
- 4. GOLD PER MIL-G-45204, TYPE II, 0.00127 [.000050] MIN THK.
- 5. GOLD PER MIL-G-45204, TYPE II, 0.00127 [.000050] MIN THK OVER NICKEL PER QQ-N-290 0.00127 [.000050] MIN THK ON CONTACT AREA.
- 6. RECOMMENDED HOLE SIZE, PLATED OR UNPLATED:
 MACHINE INSERTION: 1.32 ^{+0.08}/_{-0.05} [.052 ^{+0.003}/_{-0.002}]
 HAND INSERTION: 1.32 ^{+0.10}/_{-0.00} [.052 ^{+0.004}/_{-0.000}]
- 7. APPLICATION TOOL PART NUMBER:
 MACHINE NO. 682127-3
 INSERTION HEAD NO. 682039-2
- 8. TO INSURE PROPER SPRING TENSION DO NOT EXCEED A 0.10 [.004] DIFFERENCE IN PIN DIA WHEN CHANGING TO A SMALLER PIN.
- 9. BOTTOM PLUG KNOCKOUT TOOL PART NUMBER 69729 WITH TIP PART NUMBER 69728.
- 10. TIN PER ASTM B545, 0.00254 [.000100] MIN THK.
- 11. MATERIAL: SPRING: BERYLLIUM COPPER QQ-C-533
 EYELET: COPPER, QQ-C-576

SUPSD BY 50462-8	CLOSED	0.36-0.66 [.014-.026]	TIN 10	TIN 10	6-50462-7
	OPEN		GOLD 4	GOLD 5	1-50462-5
OBSOLETE	CLOSED	0.36-0.66 [.014-.026]	TIN 1	GOLD 2	50462-8
	KNOCKOUT		TIN 1	TIN 1	50462-7
OBSOLETE	OPEN	0.36-0.66 [.014-.026]	GOLD 3	GOLD 2	50462-6
			TIN 1	TIN 1	50462-5
OBSOLETE		0.36-0.66 [.014-.026]	GOLD 3	GOLD 2	50462-4
			GOLD 3	GOLD 2	50462-2
OBSOLETE		0.36-0.66 [.014-.026]	EYELET	SPRING	50462
	BOTTOM TYPE	RECOMMENDED PIN DIA 8	FINISH		PART NO

THIS DRAWING IS A CONTROLLED DOCUMENT.		DWN R. TALLEY 4-5-91	TE Connectivity MINIATURE SPRING SOCKET ASSEMBLY, SERIES 2		
DIMENSIONS: mm [INCHES]		CHK -			
TOLERANCES UNLESS OTHERWISE SPECIFIED:		APVD -	PRODUCT SPEC		
0 PLC ± -		PRODUCT SPEC -	APPLICATION SPEC		
1 PLC ± -		APVD -	SIZE		
2 PLC ± -		APVD -	CAGE CODE		
3 PLC ± 0.20 [.008]		APVD -	DRAWING NO		
4 PLC ± -		APVD -	RESTRICTED TO		
ANGLES ± -		APVD -	A3 00779 C-50462		
MATERIAL 11		WEIGHT -	SCALE 20:1 SHEET 1 OF 1 REV AG2		
FINISH -		CUSTOMER DRAWING			

单击下面可查看定价，库存，交付和生命周期等信息

[>>TE Connectivity\(泰科\)](#)