

THIS DRAWING IS UNPUBLISHED. RELEASED FOR PUBLICATION  
 © COPYRIGHT - TE Connectivity ALL RIGHTS RESERVED.

REVISIONS					
P	LTR	DESCRIPTION	DATE	DWN	APVD
H		ADDED 2-35135-2 PER PR 94-6	2/2/94	DKS	DAP
H1		REVISED PER ECO-17-018181	12DEC2017	RS	DR

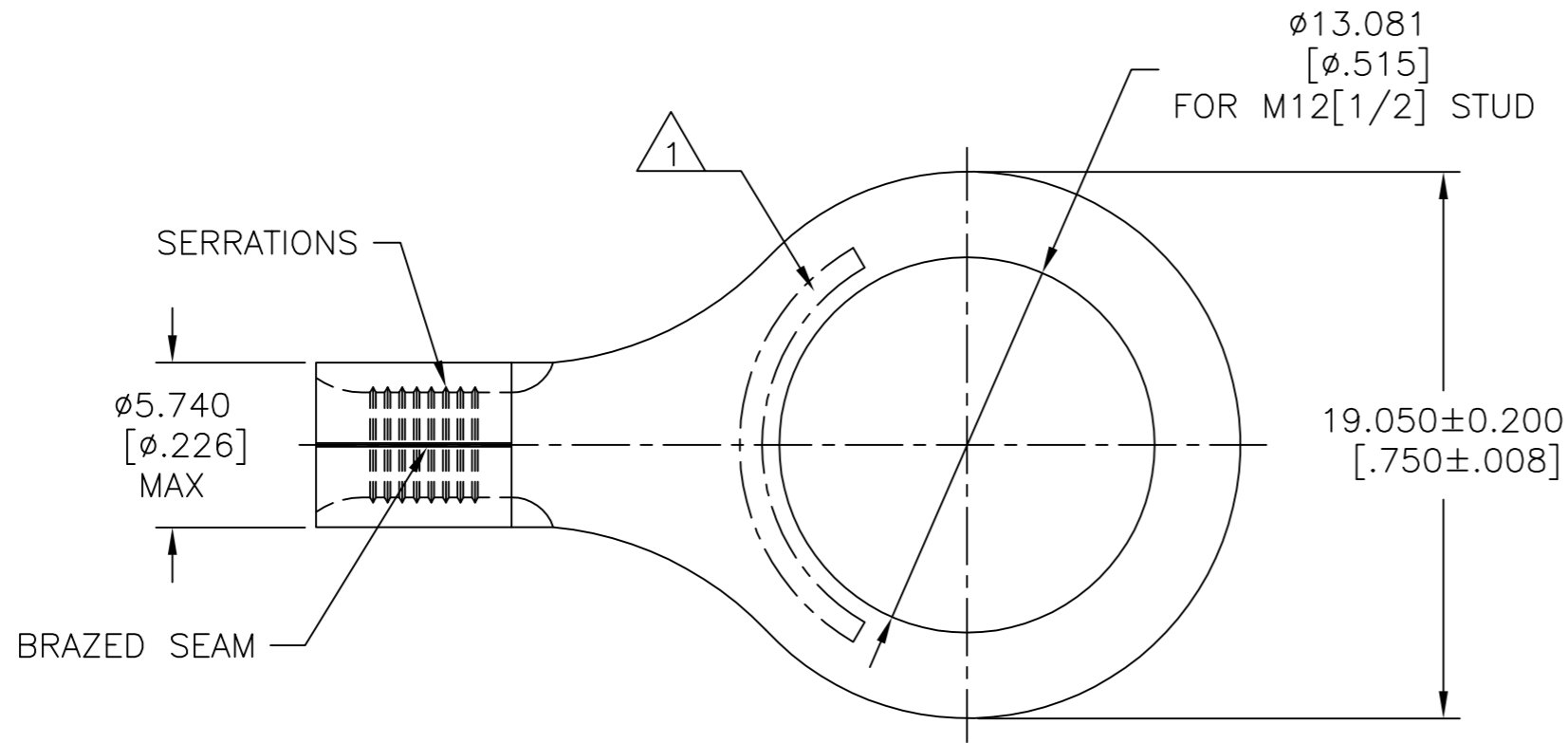

<b>AMP</b> WIRE RANGE	E13288 Listed
12-10 AWG SOLID OR STRANDED	12-10 AWG STRANDED
LR7189 Certified	MILITARY P/N AND CLASS
12-10 AWG SOLID OR STRANDED	MS 20659-166 CLASS 2

STAMP AMP 12-10\* APPROX AS SHOWN.

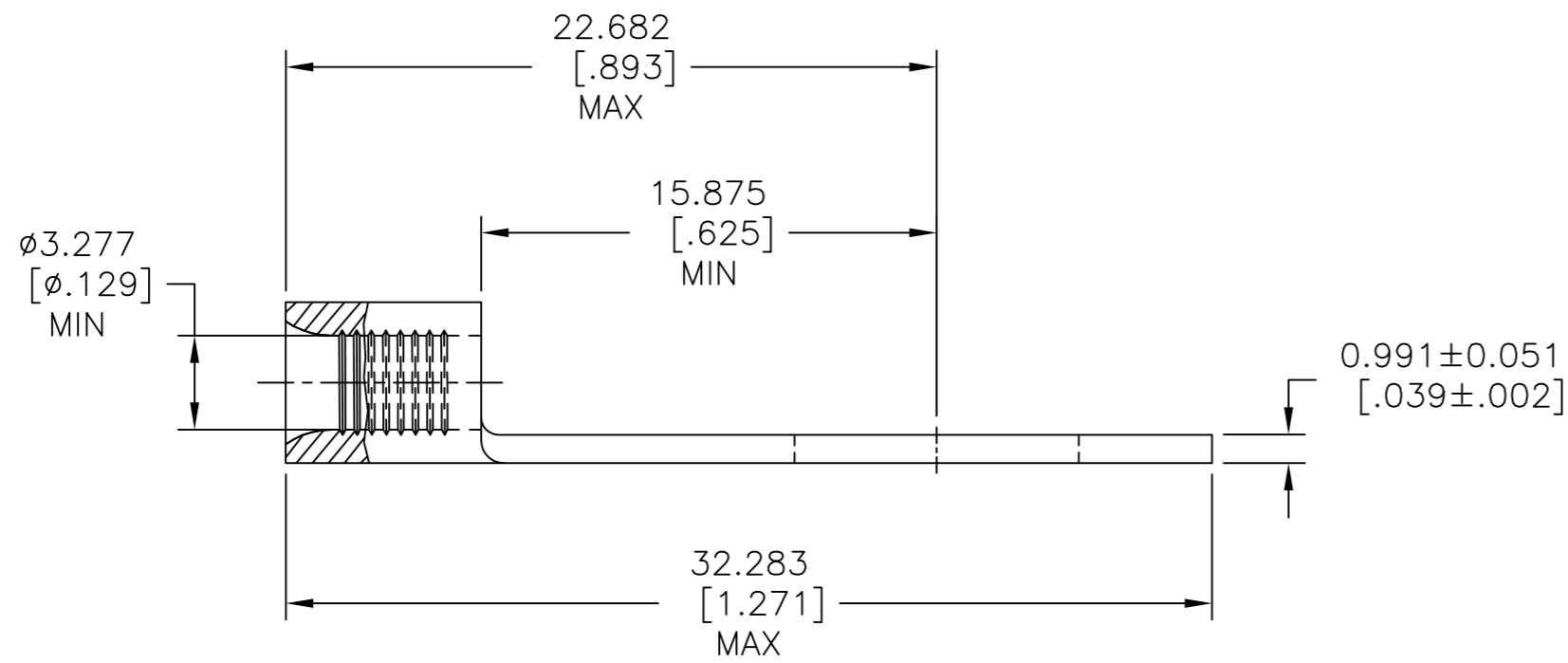

AMP INCORPORATED  
CUSTOMER SERVICE SYSTEMS

MAX RECOMMENDED OPERATING TEMPERATURE:  
170°C [338°F] MAX

FOR ADDITIONAL PRODUCT INFORMATION OR COPIES OF DRAWINGS AND TECHNICAL DOCUMENTS

PRODUCT INFORMATION CENTER  
1-800-522-6752

VOLTAGE RATING:  
NOT APPLICABLE

FOR APPLICATION TOOLING INFORMATION

TOOLING ASSISTANCE CENTER  
1-800-722-1111

WIRE CROSS SECTIONAL AREA RANGE:  
2.62-6.64mm<sup>2</sup> [5,180-13,100] CIR MILS  
SOLID OR STRANDED

FOR ORDER ENTRY

1-800-526-5142

THIS DRAWING IS A CONTROLLED DOCUMENT FOR AMP INCORPORATED. IT IS SUBJECT TO CHANGE AND THE CONTROLLING ENGINEERING ORGANIZATION SHOULD BE CONTACTED FOR THE LATEST REVISION.

	1000	TAPE MOUNTED	2-35135-2
	500	LOOSE PIECE	35135
	QTY.	PACKAGE TYPE	PART NUMBER

THIS DRAWING IS A CONTROLLED DOCUMENT.		DWN TA BRINKMAN 3-17-93	TE Connectivity	
DIMENSIONS: mm [INCHES]		CHK DA PATTERSON 3-17-93	NAME DE MILLER	
TOLERANCES UNLESS OTHERWISE SPECIFIED:		APVD DE MILLER 3-17-93	PRODUCT SPEC UL486 A-B OR SAE AS7928	
0 PLC ± -		APPLICATION SPEC		
1 PLC ± -		-		
2 PLC ± -		SIZE A2		
3 PLC ± 0.127[.005]		CAGE CODE 00779		
4 PLC ± -		DRAWING NO C=35135		
ANGLES ± -		RESTRICTED TO		
FINISH		WEIGHT -		
MATERIAL COPPER PER ASTM B-152 ANNEALED		SCALE 4:1		
TIN PLATE 0.00254[.000100] MIN THK PER ASTM B545		SHEET 1 OF 1		
CUSTOMER DRAWING		REV H1		

单击下面可查看定价，库存，交付和生命周期等信息

[>>TE Connectivity\(泰科\)](#)