

© 2019 TE Connectivity. All Rights Reserved.

REVISIONS					
P	LTR	DESCRIPTION	DATE	DWN	APVD
A		INITIAL RELEASE	18SEP2019	MM	-
B		REVISED PER ECR-21-003259	09DEC2020	MM	-

- 1 Mit Schraubensicherung
Loctite 243 gesichert
Locked with threadlocker
Loctite 243
- 2 Bei Erstmontage
vollstaendig einschrauben
Insert complete for
initial assembly
- 3 !!! Achtung:
Vor Einsatz im Umbausatz
Maße kontrollieren und ggf.
einstellen
!!! Attention:
Check measurement before
using on conversion kit.
Too long adjusted fingers
may damage the finger
and conversion kit

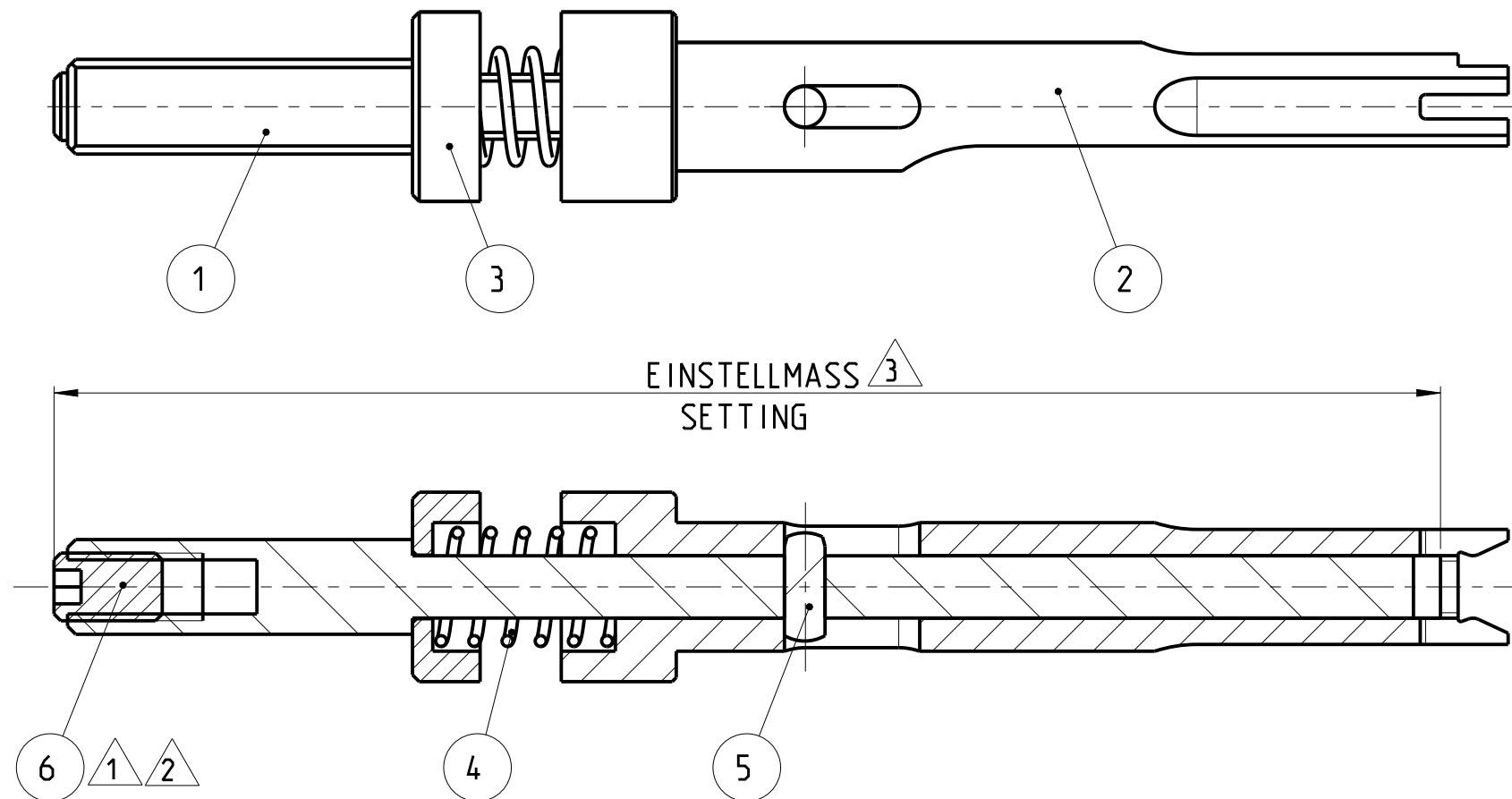

POS	QTY	TE/PN	PART REV	DESCRIPTION	WEAR	SPARE
1	1	6-1372734-7	A	SETZFINGER INSERTION FINGER	-	YES
2	1	2-1372569-8	B	HUELSE SLEEVE	-	YES
3	1	2-1372569-9	A	FEDERPLATTE SPRING PLATE	-	-
4	1	2-653861-0	A1	DRUCKFEDER COMPRESSION SPRING	-	YES
5	1	2-519051-9_GATD_DKB	A	Zyl.-Stift 3m6x8 DIN 6325 pin 3m6x8 DIN 6325	-	-
6	1	3-519011-7	B	SCREW M5x8 DIN 913	-	YES

THIS DRAWING IS A CONTROLLED DOCUMENT.		DWN M.MEYER 18SEP2019			
DIMENSIONS: mm		CHK -			
TOLERANCES UNLESS OTHERWISE SPECIFIED:		APVD -	NAME SETZFINGER KOMPLETT INSERTION FINGER COMPLETE		
0 PLC ± 1 PLC ± 2 PLC ± 3 PLC ± 4 PLC ± ANGLES ±		PRODUCT SPEC -			
MATERIAL -		FINISH -	APPLICATION SPEC -	SIZE A3	
		WEIGHT -	RESTRICTED TO	CAGE CODE 00779	
			DRAWING NO G-6-1372733-7	SHEET 1 OF 1	
			CUSTOMER DRAWING	SCALE 2:1	REV B

单击下面可查看定价，库存，交付和生命周期等信息

[>>TE Connectivity\(泰科\)](#)