

THIS DRAWING IS UNPUBLISHED. RELEASED FOR PUBLICATION 2003  
 © COPYRIGHT 2003 BY TYCO ELECTRONICS CORPORATION. ALL RIGHTS RESERVED.

LOC	DIST	REVISIONS				
P	LTR	DESCRIPTION	DATE	DWN	APVD	
A	-	EGCO-0193-04	07.09.2004	witt	-	

Matrize in Kombination mit Ergocrimp Basishandzange PN 539635-1 verwenden  
 Use die in combination with Ergocrimp basis hand tool PN 539635-1

Matrize im Karton mit Bedienungsanleitung 411-18284 verpackt  
 Die packed in a cardboard with instruction sheet 411-18284

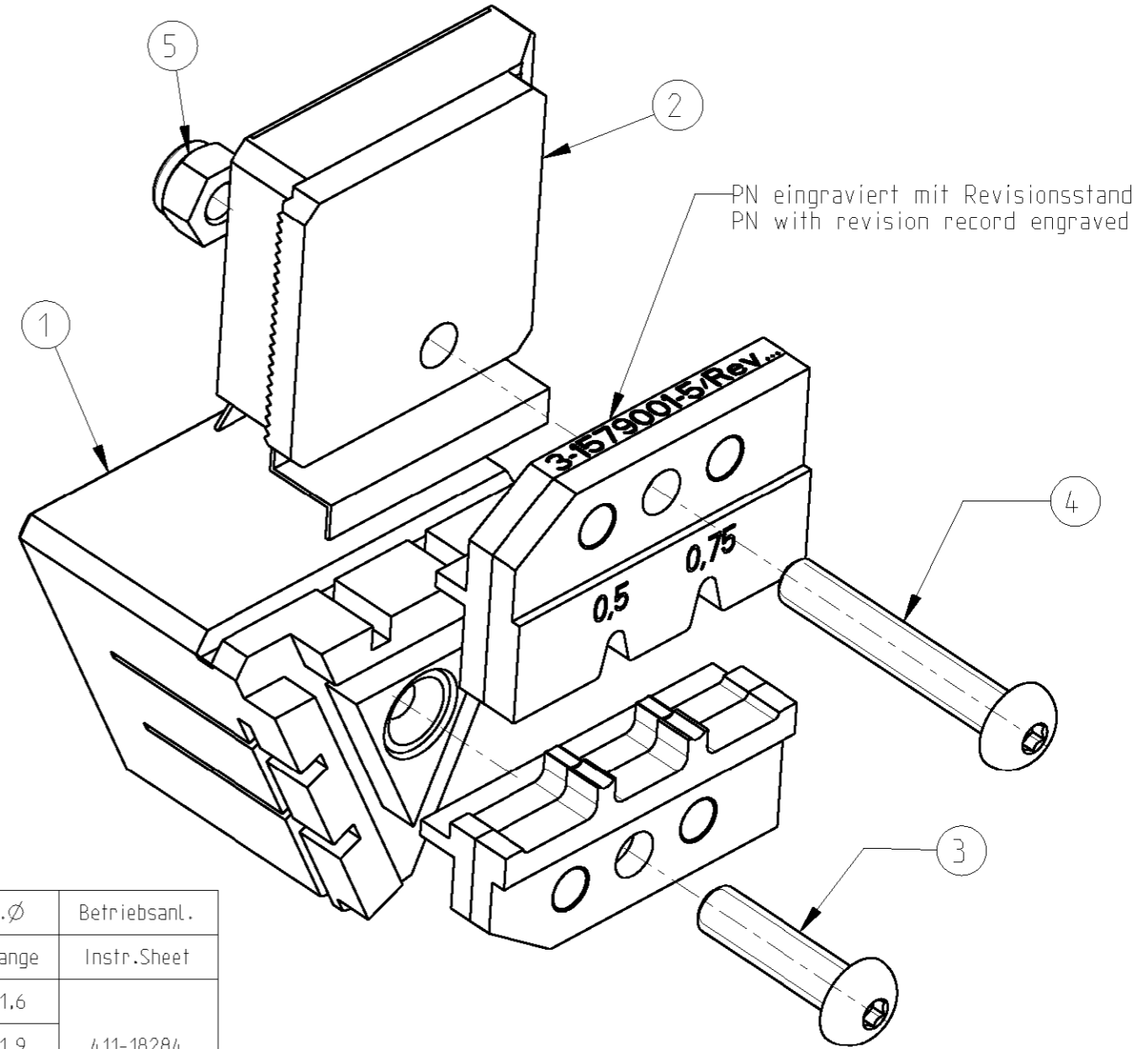

3-1579001-5	1	5-0744010-1	Instruction Sheet	Bedienungsanleitung	6
	1	0-0519024-2	Nut M4 DIN 985	Mutter M4 DIN 985	5
	1	1-0519151-3	Screw M4x25	Schraube M4x25	4
	1	1-0519151-1	Screw M4x16	Schraube M4x16	3
	1	8-1579005-9	Locator Assembly	Drahtanschlag	2
	1	8-1579005-4	Contact Locator	Kontaktpositionierer	1
	QTY Stck	PN	Description	Benennung	Pos.

Kontakt	DGB (mm <sup>2</sup> )	Drahtcrimp / Wire Crimp		Isolationscrimp/Insulationcrimp		Isol.Ø	Betriebsanl.
Contact	Wire Range	Hoehe/Height mm	Breite/Width mm	Hoehe/Height mm	Breite/Width mm	Ins.Range	Instr.Sheet
963729 / 963730 968221 / 1241921 1452014	0.50	0.93 ±0.03	1.40	1.7 ±0.1	2.03 ±0.1	1.4-1.6	411-18284
	0.75	1.07 ±0.03		2.05 ±0.1		1.7-1.9	
	-----	-----		-----		-----	

THIS DRAWING IS A CONTROLLED DOCUMENT FOR TYCO ELECTRONICS CORPORATION IT IS SUBJECT TO CHANGE AND THE CONTROLLING ENGINEERING ORGANIZATION SHOULD BE CONTACTED FOR THE LATEST REVISION.		DWN Ch.Witt 07SEP2004 CHK - APVD - PRODUCT SPEC - APPLICATION SPEC - WEIGHT -	<b>tyco</b> <b>Electronics</b> tyco Electronics AMP GmbH D - 64625 Bensheim
DIMENSIONS: mm 		TOLERANCES UNLESS OTHERWISE SPECIFIED: 0 PLC ± 1 PLC ± 2 PLC ± 3 PLC ± 4 PLC ± ANGLES ±1° MATERIAL - FINISH -	NAME <b>ERGOCRIMP-DIE SET</b> Ergocrimp Matrize
SIZE A3 CAGE CODE 00779 DRAWING NO C-3-1579001-5		RESTRICTED TO -	
CUSTOMER DRAWING		SCALE 2:1	SHEET 1 OF 1 REV A

单击下面可查看定价，库存，交付和生命周期等信息

[>>TE Connectivity\(泰科\)](#)