

THIS DRAWING IS UNPUBLISHED. RELEASED FOR PUBLICATION 2005
 © COPYRIGHT 2005 BY TYCO ELECTRONICS CORPORATION. ALL RIGHTS RESERVED.

LOC	DIST	REVISIONS			
P	LTR	DESCRIPTION	DATE	DWN	APVD
A1	-				

Matrize in Kombination mit Ergocrimp Basishandzange PN 539635-1 verwenden
 Use die in combination with Ergocrimp basis hand tool PN 539635-1

Matrize im Karton mit Bedienungsanleitung 411-18346 verpackt
 Die packed in a cardboard with instruction sheet 411-18346

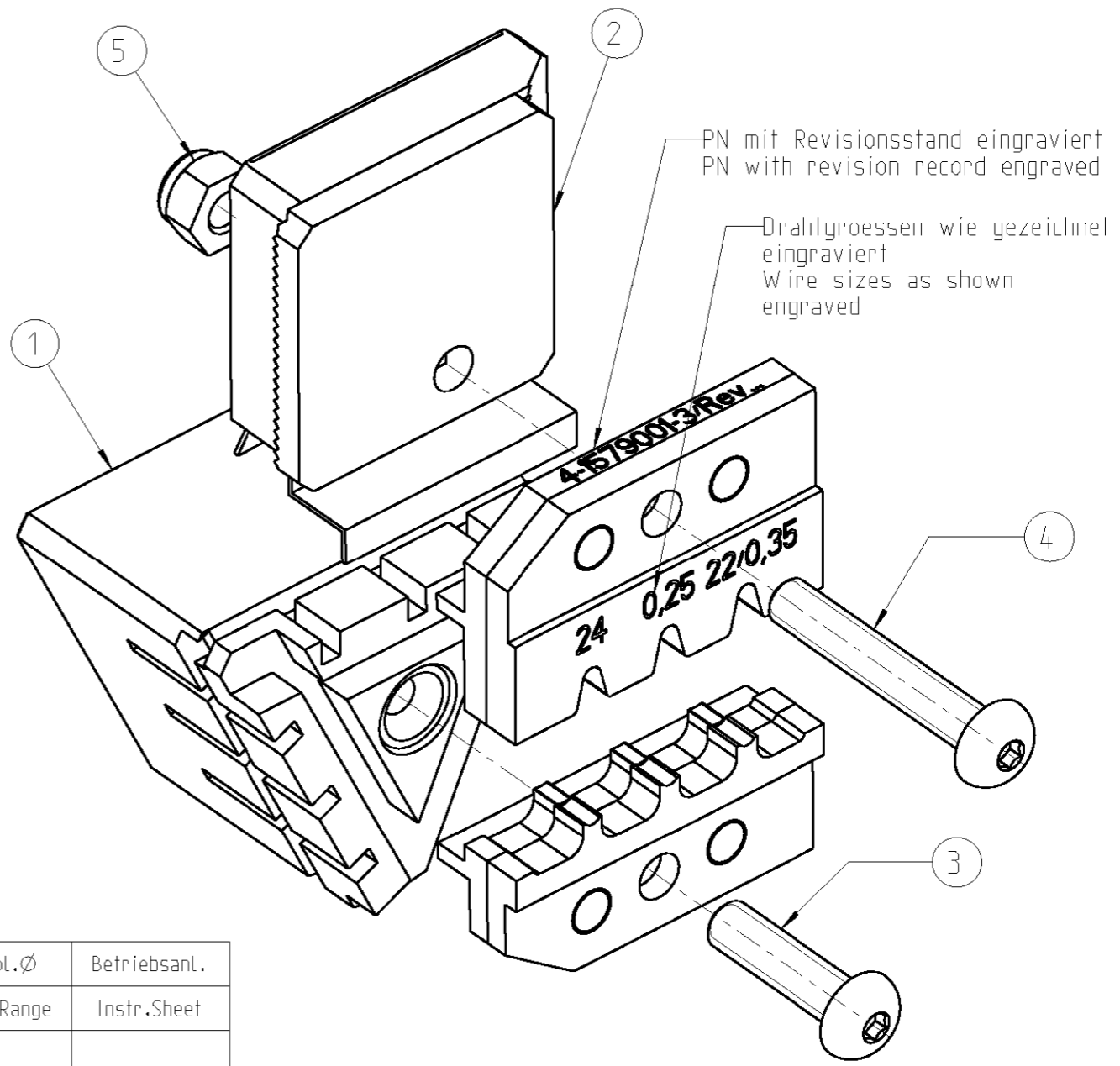

4-1579001-3	1	6-0744001-3	Instruction Sheet	Bedienungsanleitung	6
	1	0-0519024-2	Nut M4 DIN 985	Mutter M4 DIN 985	5
	1	1-0519151-3	Screw M4x25	Schraube M4x25	4
	1	1-0519151-1	Screw M4x16	Schraube M4x16	3
	1	0-1579006-6	Locator Assembly	Drahtanschlag	2
	1	0-1579006-5	Contact Locator	Kontaktpositionierer	1
	QTY Stck	PN	Description	Benennung	Pos.

Kontakt	DGB (mm ²)	Drahtcrimp / Wire Crimp		Isolationscrimp/Insulationcrimp		Isol.Ø	Betriebsanl.
Contact	AWG	Hoehe/Height mm	Breite/Width mm	Hoehe/Height mm	Breite/Width mm	Ins.Range	Instr.Sheet
1418759 / 1452654	24	0.75 ±0.03	1.27	1.75 ±0.1	1.78 (1.85max.)	1.1-1.75	411-18346
	0.25	0.78 ±0.03		1.75 ±0.1			
	22/0.35	0.83 ±0.03		1.85 ±0.1			

<small>THIS DRAWING IS A CONTROLLED DOCUMENT FOR TYCO ELECTRONICS CORPORATION IT IS SUBJECT TO CHANGE AND THE CONTROLLING ENGINEERING ORGANIZATION SHOULD BE CONTACTED FOR THE LATEST REVISION.</small>		DWN Ch.Witt 08MAY2006 CHK - APVD - PRODUCT SPEC - APPLICATION SPEC - WEIGHT 200 g		tyco Electronics tyco Electronics AMP GmbH D - 64625 Bensheim	
DIMENSIONS: mm 		TOLERANCES UNLESS OTHERWISE SPECIFIED: 0 PLC ± 1 PLC ± 2 PLC ± 3 PLC ± 4 PLC ± ANGLES ±1°		NAME ERGOCRIMP-DIE SET MCP1.2 LL Ergocrimp Matrize MCP1.2 LL	
MATERIAL - FINISH -		CUSTOMER DRAWING		SIZE A3 CAGE CODE 00779 DRAWING NO C-4-1579001-3 RESTRICTED TO - SCALE 2:1 SHEET 1 OF 1 REV A	

单击下面可查看定价，库存，交付和生命周期等信息

[>>TE Connectivity\(泰科\)](#)