

THIS DRAWING IS UNPUBLISHED.
VERTRAULICHE UNVEROEFFENTLICHTE ZEICHNUNG

RELEASED FOR PUBLICATION
FREI FUER VEROEFFENTLICHUNG

MATED WITH:
PASSEND ZU:

LOC
A1

DIST
-

REVISIONS
AENDERUNGEN

© COPYRIGHT 2000 BY -

ALL RIGHTS RESERVED.
ALLE RECHTE VORBEHALTEN

P	LTR	DESCRIPTION BESCHREIBUNG	DATE	DWN	APVD
	B	SUPERSEDED STATUS REVOKED AND NOTE 2 UPDATED	27OCT2009	PKS	RRP
	B1	1- -1 AND 1- -2 VERSIONS ADDED	23JAN2013	PKS	TK

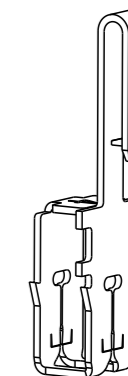
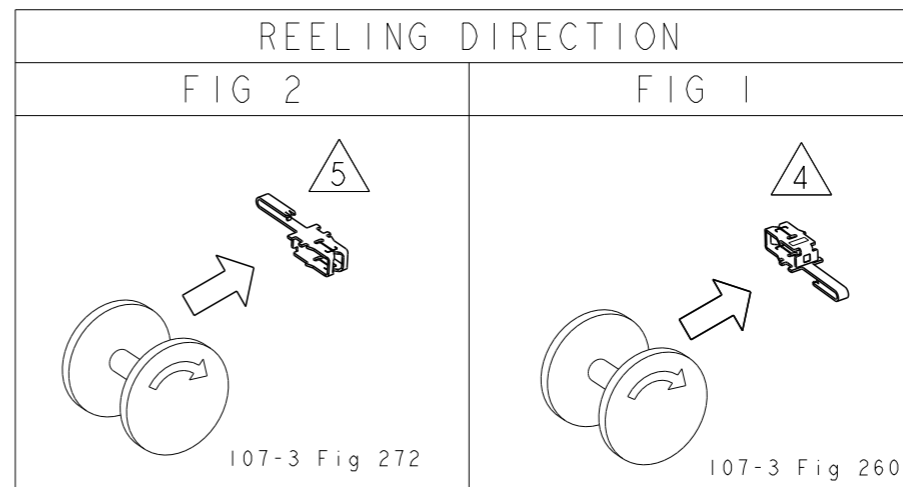
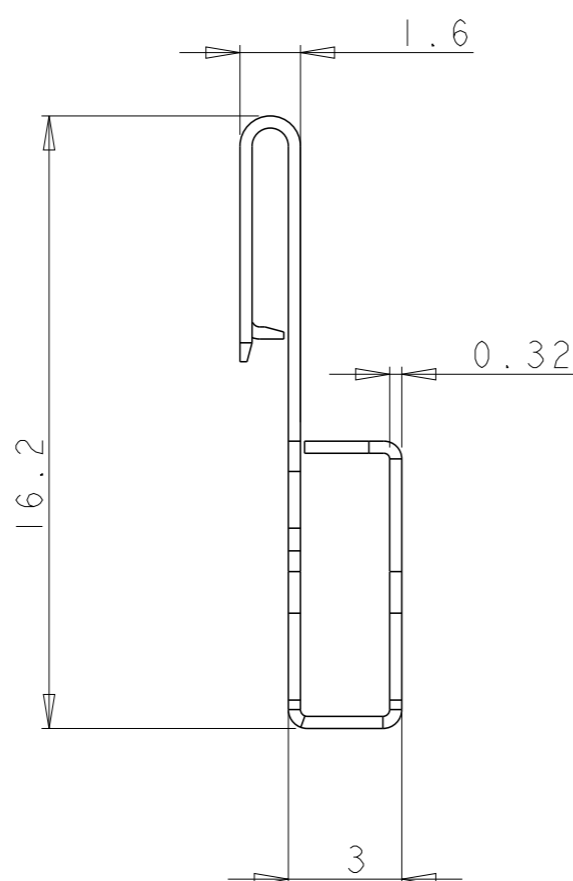
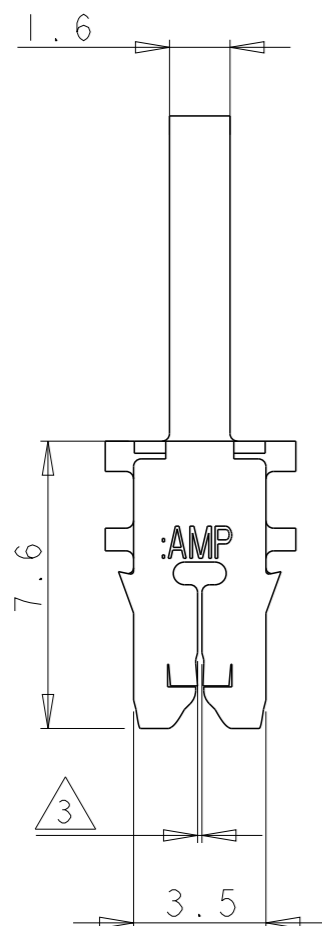

FEED 5.0±0.08

3 Schlitz geeignet fuer Kupferlackdraht einfach oder doppelt $\varnothing 0.18 \dots 0.265\text{mm}$
 SLOT ACCEPTS: SINGLE OR DOUBLE MAGNET WIRE $\varnothing 0.18 \dots 0.265\text{mm}$

2 Kontaktkammer nach Zeichnung Nr. 411-18517
 CONTACT CAVITY ACCORDING DWG-NO. 411-18517

1 Kennziffer fuer Lackdrahtbereich (4)
 IDENTIFIKATION NO. FOR MAGNET WIRE RANGE (4)

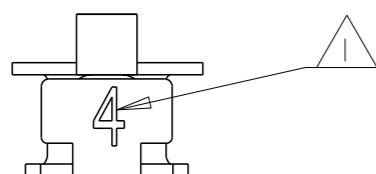

1-1394429-2	CuNiSi	VORVERZINNT	5
1-1394429-1	CuNiSi	VORVERZINNT	5
1394429-2	CuZn30	VORVERZINNT	4
1394429-1	CuNiSi	VORVERZINNT	4
BESTELL-NR.	WERKSTOFF	OBERFLAECHE	BEMERKUNGEN

THIS DRAWING IS A CONTROLLED DOCUMENT. DIESES ZEICHNUNGSDOKUMENT WIRD DURCH AMP INCORPORATED KONTROLLIERT. AENDERUNGEN, DIE DEM TECHNISCHEN FORTSCHRITT DIENEN, SIND VORBEHALTEN. DEN JEWELIS LETZTGUELTIGEN AENDERUNGSSTAND ERFAHREN SIE AUF ANFRAGE.		DWN H. ATZMANN 27SEP2000	STE TE Connectivity	
DIMENSIONS: MASSEINHEITEN: mm		CHK H. PLOESSER 27SEP2000		
TOLERANCES UNLESS OTHERWISE SPECIFIED: ALLGEMEINTOLERANZEN		APVD T. KLENNER 27SEP2000	NAME MAG-MATE CONTACT RAST 5 D	
0 PLC ± 1 PLC ±0.2 2 PLC ±0.2 3 PLC ±0.2 4 PLC ± ANGLES/WINKEL ±1°		PRODUCT SPEC PRODUKTSPEZ.	DRAWING NO ZEICHNUNGS-NR.	
MATERIAL S. TAB.		APPLICATION SPEC VERARBEITUNGSSPEZ.	SIZE A300779	RESTRICTED TO NUR FUER
FINISH/OBERFLAECHE/FARBE S. TAB.		WEIGHT GEWICHT	DRAWING NO ZEICHNUNGS-NR. G=1394429	REV B1
		Customer Drawing	SCALE MASSSTAB 5:1	SHEET BLATT 1 OF VON 1

单击下面可查看定价，库存，交付和生命周期等信息

[>>TE Connectivity\(泰科\)](#)